



# Maintenance and Service Guide

## **SUMMARY**

This guide provides information about spare parts, removal and replacement of parts, security, backing up, and more. HP recommends that you configure Windows to update automatically to make sure that the computer has the latest software and security updates.

© Copyright 2021 HP Development Company, L.P.

AMD is a trademark of Advanced Micro Devices, Inc. Bluetooth is a trademark owned by its proprietor and used by HP Inc. under license. Intel is a trademark of Intel Corporation or its subsidiaries in the U.S. and/or other countries. Microsoft and Windows are either registered trademarks or trademarks of Microsoft Corporation in the United States and/or other countries. Qualcomm and Snapdragon are trademarks of Qualcomm Incorporated, registered in the United States and other countries, used with permission. USB Type-C and USB-C are registered trademarks of USB Implementers Forum. DisplayPort™ and the DisplayPort™ logo are trademarks owned by the Video Electronics Standards Association (VESA®) in the United States and other countries. Miracast is a registered trademark of Wi-Fi Alliance.

The information contained herein is subject to change without notice. The only warranties for HP products and services are set forth in the express warranty statements accompanying such products and services. Nothing herein should be construed as constituting an additional warranty. HP shall not be liable for technical or editorial errors or omissions contained herein.

HP Elite Slim Active Pen: The Regulatory Model Number (RMN) for this equipment is STA-WP01.

Second Edition: March 2021

First Edition: February 2021

Document Part Number: M28702-002

## Product notice

This guide describes features that are common to most models. Some features may not be available on your computer.

Not all features are available in all editions or versions of Windows. Systems may require upgraded and/or separately purchased hardware, drivers, software or BIOS update to take full advantage of Windows functionality. Windows 10 is automatically updated, which is always enabled. ISP fees may apply and additional requirements may apply over time for updates. Go to <http://www.microsoft.com> for details.

To access the latest user guides, go to <http://www.hp.com/support>, and follow the instructions to find your product. Then select **Manuals**.

## Software terms

By installing, copying, downloading, or otherwise using any software product preinstalled on this computer, you agree to be bound by the terms of the HP End User License Agreement (EULA). If you do not accept these license terms, your sole remedy is to return the entire unused product (hardware and software) within 14 days for a full refund subject to the refund policy of your seller.

For any further information or to request a full refund of the price of the computer, please contact your seller.

## Safety warning notice

Reduce the possibility of heat-related injuries or of overheating the computer by following the practices described.

---

 **WARNING!** To reduce the possibility of heat-related injuries or of overheating the computer, do not place the computer directly on your lap or obstruct the computer air vents. Use the computer only on a hard, flat surface. Do not allow another hard surface, such as an adjoining optional printer, or a soft surface, such as pillows or rugs or clothing, to block airflow. Also, do not allow the AC adapter to come into contact with the skin or a soft surface, such as pillows or rugs or clothing, during operation. The computer and the AC adapter comply with the user-accessible surface temperature limits defined by applicable safety standards.

---



---

# Table of contents

<b>1 Product description</b> .....	<b>1</b>
<b>2 Components</b> .....	<b>4</b>
Right .....	4
Left .....	5
Display .....	5
Keyboard area .....	7
Touchpad .....	7
Touchpad settings .....	7
Adjusting touchpad settings .....	7
Turning on the touchpad .....	7
Touchpad components .....	7
Lights .....	8
Button, speakers, and SIM card tray .....	9
Using your HP Elite Slim Active Pen .....	10
Special keys .....	11
Labels .....	12
Using a SIM card .....	14
Determining the correct SIM card size for your computer .....	14
Inserting a SIM card in the digital pen pocket .....	14
<b>3 Illustrated parts catalog</b> .....	<b>16</b>
Computer major components .....	16
Miscellaneous parts .....	18
<b>4 Removal and replacement procedures preliminary requirements</b> .....	<b>20</b>
Tools required .....	20
Service considerations .....	20
Plastic parts .....	20
Cables and connectors .....	20
Drive handling .....	20
Electrostatic discharge information .....	21
Generating static electricity .....	21
Preventing electrostatic damage to equipment .....	22
Personal grounding methods and equipment .....	22
Grounding the work area .....	23

Recommended materials and equipment .....	23
Cleaning your computer .....	24
Enabling HP Easy Clean (select products only) .....	24
Removing dirt and debris from your computer .....	24
Cleaning your computer with a disinfectant .....	25
Caring for wood veneer (select products only) .....	26
Packaging and transporting guidelines .....	26
Accessing support information .....	26
<b>5 Removal and replacement procedures for Customer Self-Repair parts .....</b>	<b>28</b>
Component replacement procedures .....	28
Preparation for disassembly .....	28
Pen .....	28
<b>6 Removal and replacement procedures for authorized service provider parts .....</b>	<b>30</b>
Component replacement procedures .....	30
Bottom cover .....	30
Battery .....	31
Speakers .....	33
Touchpad .....	34
Wireless antennas and cables (installed on top cover) .....	35
Heat sink .....	36
Solid-state drive .....	37
WWAN module .....	39
System board .....	41
POGO connector .....	43
Antenna bar .....	44
Top cover with keyboard .....	45
Display assembly .....	46
<b>7 Backing up, restoring, and recovering .....</b>	<b>52</b>
Backing up information and creating recovery media .....	52
Using Windows tools for backing up .....	52
Restoring and recovering your system .....	52
Creating a system restore .....	52
Restoring and recovery methods .....	52
<b>8 Computer Setup (BIOS) .....</b>	<b>53</b>
Using Computer Setup .....	53
Navigating and selecting in Computer Setup .....	53

Updating the BIOS .....	53
<b>9 Using HP PC Hardware Diagnostics UEFI .....</b>	<b>54</b>
Using an HP PC Hardware Diagnostics Windows hardware failure ID code .....	54
Starting HP PC Hardware Diagnostics UEFI .....	54
Downloading HP PC Hardware Diagnostics UEFI to a USB flash drive .....	55
Downloading the latest HP PC Hardware Diagnostics UEFI version .....	55
Downloading HP PC Hardware Diagnostics UEFI by product name or number .....	55
<b>10 Specifications .....</b>	<b>56</b>
Computer specifications .....	56
Display specifications .....	56
Solid-state drive specifications .....	57
<b>11 Statement of memory volatility .....</b>	<b>58</b>
Current BIOS steps .....	58
Nonvolatile memory usage .....	60
Questions and answers .....	62
Using HP Sure Start (select products only) .....	63
<b>12 Recycling .....</b>	<b>64</b>
<b>13 Power cord set requirements .....</b>	<b>65</b>
Requirements for all countries .....	65
Requirements for specific countries and regions .....	65
<b>Index .....</b>	<b>67</b>





# 1 Product description

This table provides detailed product information.

**Table 1-1 Product components and their descriptions**

Category	Description
<b>Product Name</b>	<b>HP Elite Folio 13.5 inch 2-in-1 Notebook PC</b>
<b>Processors</b>	<b>Qualcomm® Snapdragon™ SC8180XP (1.80 GHz base frequency, up to 3.15 GHz burst frequency, 4 MB cache, 8 cores)</b>
<b>Graphics</b>	<b>Integrated graphics</b> Supports HDCP 2.2 Supports two external displays when docked
<b>Display</b>	<b>34.3 cm (13.5 in), WLED, WUXGA+ (1920 × 1280), IPS, UWVA, 72% CG, ambient light sensor, bent, HD + IR camera</b> BrightView, 400 nits BrightView, HP Sure View Reflect, 1000 nits
<b>Memory</b>	Non upgradable integrated memory supporting up to 16 GB of RAM LPDDR4-4266 dual-channel support Supports the following configurations: <ul style="list-style-type: none"><li>• 16 GB (128 Gb)</li><li>• 8 GB (64 Gb)</li></ul>
<b>Primary storage</b>	<b>M.2 2280 solid-state drives, PCIe, NVMe</b> 512 GB, PCIe-3 × 4, TLC 256 GB, PCIe-3 × 4, TLC 128 GB, PCIe-3 × 2, PCIe, TLC
<b>Audio and video</b>	HP Bang & Olufsen Audio Stereo speakers (4) Microphone (integrated with camera, multi-array with two front-facing mics) Camera, HD + IR (infrared) 720p Camera privacy cover
<b>Wireless</b>	<b>Wireless Local Area Network (WLAN)</b> 802.11ax (2 × 2) Bluetooth® 5.1 WLAN - Compatible with Miracast® devices - Dual antennas <b>Wireless Wide Area Network (WWAN)</b> (select products only)

**Table 1-1 Product components and their descriptions (continued)**

<b>Category</b>	<b>Description</b>
	Qualcomm Snapdragon X20 LTE-Advanced (CAT16)
	- SIM accessible under pen
	- Four antennas
	Qualcomm Snapdragon X55 LTE + 5G (Cat 20)
	- Embedded eSIM and physical SIM accessible under pen
	- Four antennas
<b>Ports</b>	Audio-out (headphone)/audio-in (microphone) combo jack
	(2) USB Type-C® connectors
<b>Sensors</b>	Hall sensor
	Accelerometer
	Ambient light sensor
	Three-axis gyroscope
	Magnetometer (eCompass)
<b>Keyboard/pointing devices</b>	<b>HP Folio Keyboard</b>
	Backlit, spill resistant, with HP Dura Keys
	Backlit, spill resistant, with HP Dura Keys, privacy
	<b>Glass clickpad</b>
	Microsoft® precision touchpad default gestures support
	Firmware PTP
<b>Power requirements</b>	<b>Battery</b> (Li polymer)
	4 cell, 46 Whr
	Long life
	HP Fast Charge Technology
	<b>Smart AC adapters</b>
	65 W, straight, slim, nPFC, USB Type-C, 1.8 m (6 ft)
	<b>Power cord</b>
	C5, 1.0 m (3.3 ft) premium
<b>Security</b>	Security Core PC
	Trusted Platform Module (TPM) 2.0
	Security level 3
<b>Digital pen</b>	AES 2.0 Pen
<b>Operating system</b>	Windows® Home ARM 64
	Windows Home ARM 64 Chinese Market CPPP

**Table 1-1 Product components and their descriptions (continued)**

<b>Category</b>	<b>Description</b>
	Windows Home ARM 64 High-End Chinese Market CPPP
	Windows Home ARM 64 Plus
	Windows Home ARM 64 Plus Single Language
	Windows Home ARM 64 Plus Single Language Africa PPP
	Windows Home ARM 64 Plus Single Language APAC PPP
	Windows Home ARM 64 Single Language
	Windows Home ARM 64 Single Language Africa PPP
	Windows Home ARM 64 Single Language APAC PPP
	Windows Pro ARM 64
	Windows Pro ARM 64 Chinese Market
	Windows Pro ARM 64 StF MSNA Standard
	<b>Operating system recovery kit</b> (for service only)
	Windows 10 ARM OS USB
<b>Serviceability</b>	<b>End user replaceable parts</b>
	AC adapter
	Pen

# 2 Components

Your computer features top-rated components. This chapter provides details about your components, where they are located, and how they work.

## Right

Use the illustration and table to identify the components on the right side of the computer.

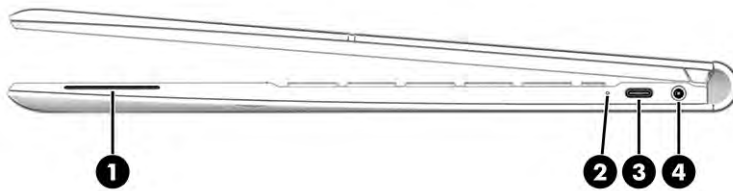
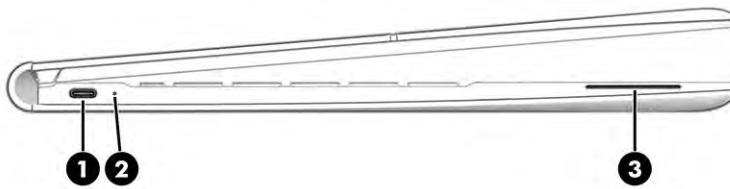

**Table 2-1 Right-side components and their descriptions**

Component	Description
(1) Speaker	Produces sound.
(2) Battery light	When AC power is connected to the USB port on either side: <ul style="list-style-type: none"><li>• White: The battery charge is greater than 90%.</li><li>• Amber: The battery charge is from 0 to 90%.</li><li>• Off: The battery is not charging.</li></ul> When AC power is disconnected (battery not charging): <ul style="list-style-type: none"><li>• Off: The battery is not charging.</li></ul>
(3) USB Type-C® port	Connects a USB device, provides data transfer, and charges small devices when the computer is on or in Sleep mode. <b>NOTE:</b> Cables, adapters, or both (purchased separately) might be required.
(4) Audio-out (headphone)/Audio-in (microphone) combo jack	Connects optional powered stereo speakers, headphones, earbuds, a headset, or a television audio cable. Also connects an optional headset microphone. This jack does not support optional standalone microphones. <b>WARNING!</b> To reduce the risk of personal injury, adjust the volume before putting on headphones, earbuds, or a headset. For additional safety information, see the <i>Regulatory, Safety, and Environmental Notices</i> . To access this guide: <ul style="list-style-type: none"><li>▲ Type <a href="#">HP Documentation</a> in the taskbar search box, and then select <b>HP Documentation</b>.</li></ul> <b>NOTE:</b> When a device is connected to the jack, the computer speakers are disabled.

## Left

Use the illustration and table to identify the components on the left side of the computer.

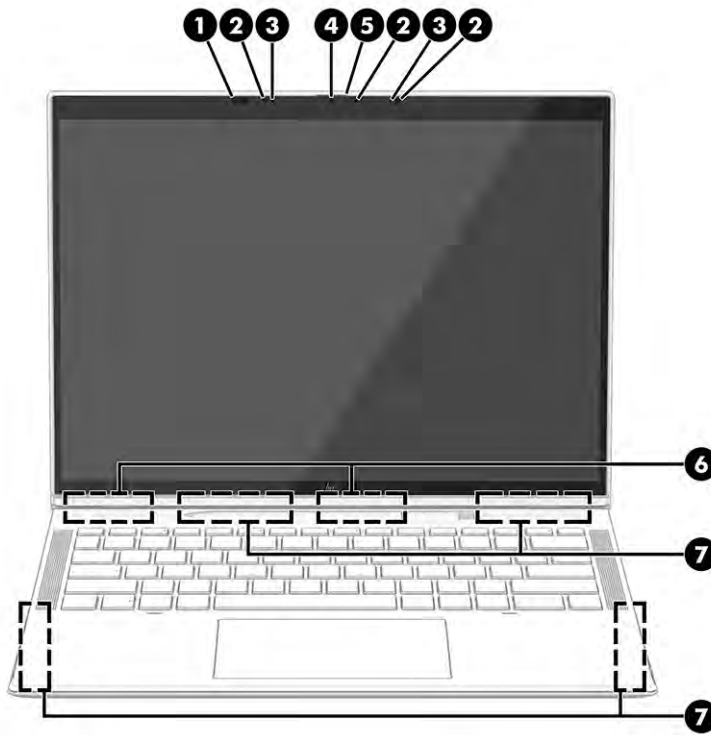

**Table 2-2 Left-side components and their descriptions**

Component	Description
(1) USB Type-C port	Connects a USB device, provides data transfer, and charges small devices when the computer is on or in Sleep mode. <b>NOTE:</b> Cables, adapters, or both (purchased separately) might be required.
(2) Battery light	When AC power is connected to the USB port on either side: <ul style="list-style-type: none"><li>• White: The battery charge is greater than 90%.</li><li>• Amber: The battery charge is from 0 to 90%.</li><li>• Off: The battery is not charging.</li></ul> When AC power is disconnected (battery not charging): <ul style="list-style-type: none"><li>• Blinking amber: The battery has reached a low battery level. When the battery has reached a critical battery level, the battery light begins blinking rapidly.</li><li>• Off: The battery is not charging.</li></ul>
(3) Speaker	Produces sound.

## Display

Use the illustration and table to identify the display components.



**Table 2-3 Display components and their descriptions**

Component	Description
(1) Ambient light sensor*	Detects ambient light in the environment.
(2) Camera lights	On: The camera is in use. <b>NOTE:</b> The infrared camera lights are used only during the Windows Hello login procedure.
(3) Internal microphones	Record sound.
(4) Camera	Allows you to video chat, record video, and record still images. Some cameras also allow a facial recognition logon to Windows®, instead of a password logon. <b>NOTE:</b> Camera functions vary depending on the camera hardware and software installed on your product.
(5) Camera privacy cover	By default, the camera lens is uncovered, but you can slide the camera privacy cover to block the camera's view. To use the camera, slide the camera privacy cover in the opposite direction to reveal the lens.
(6) WLAN antennas*	Send and receive wireless signals to communicate with wireless local area networks (WLANs).
(7) WWAN antennas (select products only)*	Send and receive wireless signals to communicate with wireless wide area networks (WWANs).

\*The ambient light sensor and antennas are not visible from the outside of the computer. For optimal WLAN and WWAN transmission, keep the areas immediately around the antennas free from obstructions.

For wireless regulatory notices, see the section of the *Regulatory, Safety, and Environmental Notices* that applies to your country or region.

To access this guide:

**Table 2-3 Display components and their descriptions (continued)**

Component	Description
▲	Type <code>HP Documentation</code> in the taskbar search box, and then select <b>HP Documentation</b> .

## Keyboard area

Keyboards can vary by language.

## Touchpad

The touchpad settings and components are described here.

### Touchpad settings

You learn how to adjust the touchpad settings and components here.

#### Adjusting touchpad settings

Use these steps to adjust touchpad settings and gestures.

1. Type `touchpad settings` in the taskbar search box, and then press `enter`.
2. Choose a setting.

#### Turning on the touchpad

Follow these steps to turn on the touchpad.

1. Type `touchpad settings` in the taskbar search box, and then press `enter`.
2. Using an external mouse, click the **Touchpad** button.

If you are not using an external mouse, press the `Tab` key repeatedly until the pointer rests on the **touchpad** button. Then press the `spacebar` to select the button.

### Touchpad components

Use the illustration and table to identify the touchpad components.

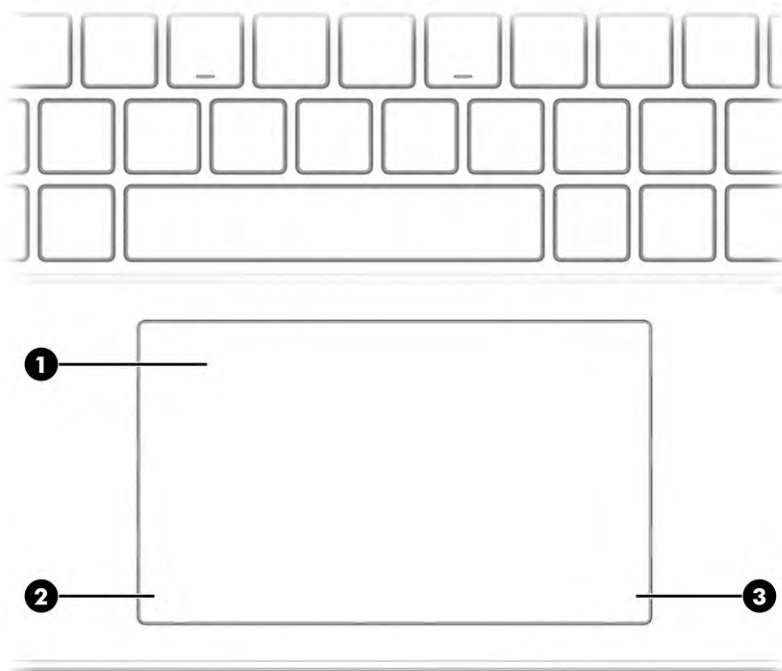

**Table 2-4 Touchpad components and their descriptions**

Component	Description
(1) Touchpad zone	Reads your finger gestures to move the pointer or activate items on the screen.
(2) Left touchpad button	Functions like the left button on an external mouse.
(3) Right touchpad button	Functions like the right button on an external mouse.

## Lights

Use the illustration and table to identify the lights on the computer.



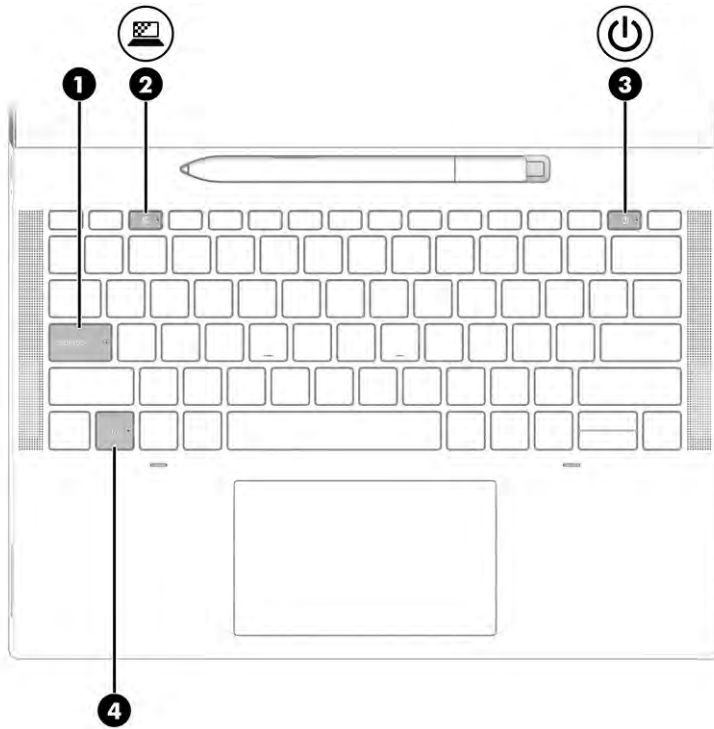
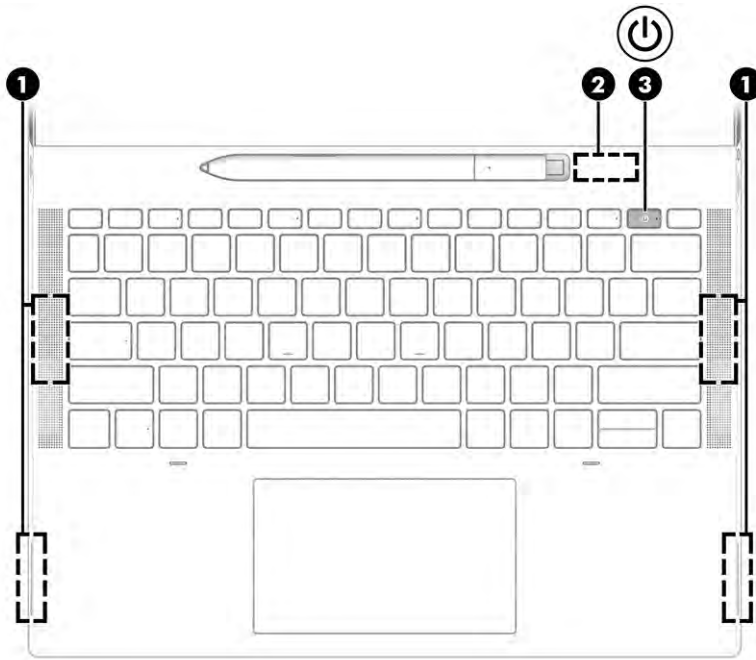

**Table 2-5 Lights and their descriptions**



Component	Description
(1) Caps lock light	On: Caps lock is on, which switches the key input to all capital letters.
(2) Privacy key light (select products only)	On: Privacy screen is on, which helps prevent side-angle viewing.
(3)  Power light	<ul style="list-style-type: none"> <li>On: The computer is on.</li> <li>Blinking: The computer is in the Sleep state, a power-saving state. The computer shuts off power to the display and other unnecessary components.</li> <li>Off: The computer is off or in Sleep.</li> </ul>
(4) Fn lock light	On: The <b>fn</b> key is locked.

## Button, speakers, and SIM card tray

Use the illustration and table to identify the button, speakers, and SIM card tray on the computer.

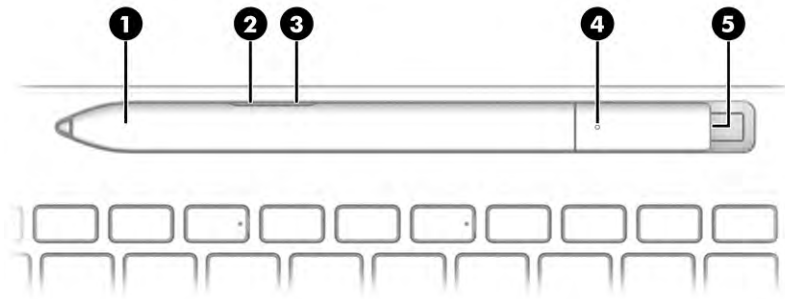

**Table 2-6 Button, speakers, and SIM card tray and their descriptions**

Component	Description
(1) Speakers	Produce sound.
(2) SIM card tray (select products only)	You can insert a SIM card in the SIM tray located inside the pen pocket. For more information, see <a href="#">Using a SIM card on page 14</a> .
(3)  Power button	<ul style="list-style-type: none"> <li>When the computer is off, press the button briefly to turn on the computer.</li> <li>When the computer is on, press the button briefly to initiate Sleep.</li> <li>When the computer is in the Sleep state, press the button briefly to exit Sleep.</li> </ul> <p><b>IMPORTANT:</b> Pressing and holding down the power button results in the loss of unsaved information.</p> <p>If the computer has stopped responding and shutdown procedures are ineffective, press and hold the power button for at least 4 seconds to turn off the computer.</p> <p>To learn more about your power settings, see your power options.</p> <p>▲ Right-click the <b>Power meter</b> icon  and then select <b>Power Options</b>.</p>

## Using your HP Elite Slim Active Pen

Use the illustration and table to identify the digital pen and its features.



**Table 2-7 Digital pen features and their descriptions**

Component	Description
(1) Digital pen pocket	A recessed area for storing and charging the digital pen.
(2) Bottom button	Erases content on the screen. <b>NOTE:</b> You can configure the action of this button in the pen software that is installed on your computer.
(3) Top button	Press and hold the button and tap the screen to imitate the action of a right-click of your mouse. <b>NOTE:</b> You can configure the action of this button in the pen software that is installed on your computer.
(4) Digital pen light	<ul style="list-style-type: none"> <li>• Blinking blue (slowly): The pen is in pairing mode.</li> <li>• Blinking blue (fast): The pen has paired successfully.</li> <li>• Solid blue: The pen is successfully paired.</li> <li>• Solid red: The pen is in over-the-air (OTA) mode.</li> <li>• Blinking red (fast): OTA is transferring information.</li> <li>• Blinking blue (very fast): OTA transfer has completed successfully.</li> <li>• Off (1 s): OTA failed.</li> <li>• Blinking red (slowly): The battery charge level is low.</li> <li>• Blinking white: The pen is charging.</li> <li>• Solid white: The pen is fully charged.</li> </ul>
(5) Pairing button	To connect your digital pen to your computer, press and hold the pairing button for 5 seconds. <b>NOTE:</b> You can configure the action of this button in the pen software that is installed on your computer.

\*The Regulatory Model Number (RMN) for this equipment is STA-WP01.



Turn on your digital pen by tapping the tip on any surface.

## Special keys

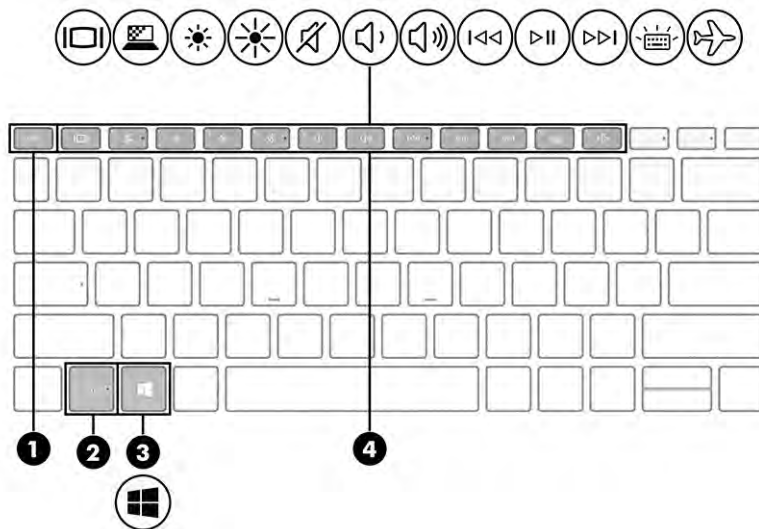
Use the illustration and table to identify the special keys.

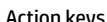

**Table 2-8 Special keys and their descriptions**

Component	Description
(1)  esc key	Displays system information when pressed in combination with the fn key.
(2)  fn key	Executes frequently used system functions when pressed in conjunction with another key.
(3)  Windows key	Opens the Start menu. <b>NOTE:</b> Pressing the Windows key again will close the Start menu.
(4)  Action keys	Execute frequently used system functions.

## Labels

The labels affixed to the computer provide information you might need when you troubleshoot system problems or travel internationally with the computer. Labels might be in paper form or imprinted on the product.

 **IMPORTANT:** Check the following locations for the labels described in this section: the bottom of the computer, inside the battery bay, under the service door, on the back of the display, or on the bottom of a tablet kickstand.

- Service label—Provides important information to identify your computer. When contacting support, you might be asked for the serial number, the product number, or the model number. Locate this information before you contact support.

Your service label will resemble one of these examples. Refer to the illustration that most closely matches the service label on your computer.



**Table 2-11 Service label components**

Component	
(1)	HP product name
(2)	Product ID
(3)	Serial number
(4)	Warranty period

- Regulatory labels—Provide regulatory information about the computer.
- Wireless certification labels—Provide information about optional wireless devices and the approval markings for the countries or regions in which the devices have been approved for use.

## Using a SIM card

Use these instructions to insert a SIM card.



**IMPORTANT:** You can damage the SIM card if you insert the wrong size card or insert it or the SIM card tray in the wrong direction. The card might also become stuck in the slot. Do not use SIM card adapters. To prevent damage to the SIM card or connectors, use minimal force when inserting or removing a SIM card.

## Determining the correct SIM card size for your computer

Before purchasing a SIM card, follow these instructions to determine the correct SIM card size for your computer.

1. Go to <http://www.hp.com/support>, and then search for your computer by product name or number.
2. Select **Product Information**.
3. Refer to the listed options to determine which card to purchase.

## Inserting a SIM card in the digital pen pocket

To insert a SIM card, follow these steps.

1. Turn off the computer by using the Shut down command.
2. Disconnect all external devices connected to the computer.
3. Unplug the power cord from the AC outlet.
4. If the digital pen is present, remove it from the pocket.

5. Insert the SIM card into the SIM card tray, and then insert the tray into the slot, and then press in on the SIM card tray until it is firmly seated.

---

 **IMPORTANT:** Do not use the digital pen to insert or remove the SIM card tray from the slot.

 **NOTE:** Your SIM card, SIM card tray, or the SIM card slot in your computer might look different from the illustration in this section.

 **NOTE:** Your SIM card slot might have an icon to show which way the card should be inserted into the computer.

---

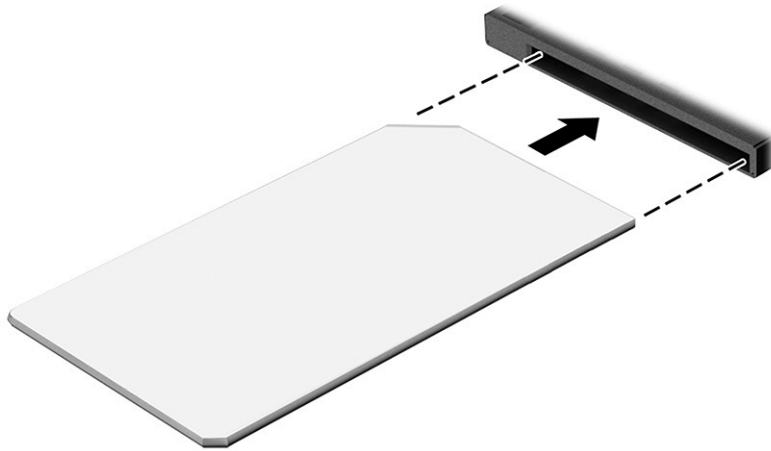

# 3 Illustrated parts catalog

Use this table to determine the spare parts that are available for the computer.

## Computer major components

To identify the computer major components, use this illustration and table.

**NOTE:** HP continually improves and changes product parts. For complete and current information about supported parts for your computer, go to <http://partsurfer.hp.com>, select your country or region, and then follow the on-screen instructions.

**NOTE:** Details about your computer, including model, serial number, product key, and length of warranty, are on the service tag at the bottom of your computer.

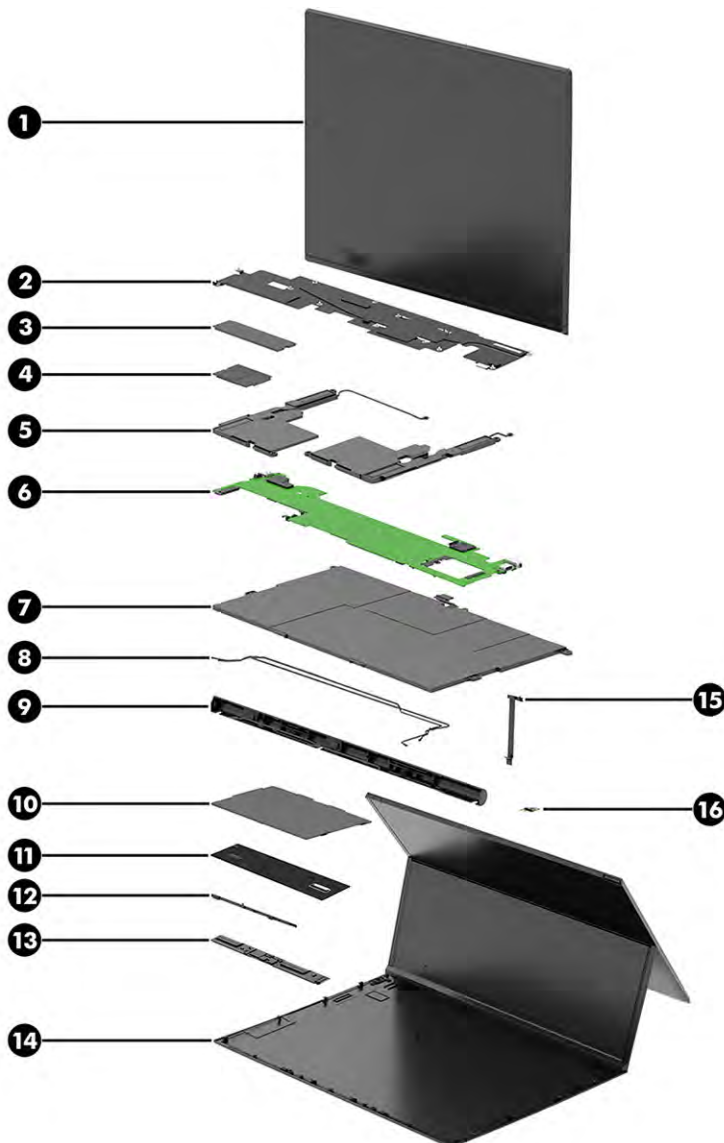



**Table 3-1 Computer major component descriptions and part numbers**

Item	Component	Spare part number
<b>(1)</b>	<b>Display panel</b>	
	BrightView, 400 nits	M35262-001
	BrightView, HP Sure View Reflect, 1000 nits	M35279-001
<b>(2)</b>	<b>Heat sink assembly</b>	M35260-001
	<b>NOTE:</b> The heat sink thermal pad kit is available as spare part number M42820-001.	
<b>(3)</b>	<b>Solid-state drive</b>	
	512 GB, PCIe-3 × 4, TLC	M54568-005
	256 GB, PCIe-3 × 4, TLC	M54567-005
	128 GB, PCIe-3 × 2, TLC	M54569-005
<b>(4)</b>	<b>WWAN module</b>	
	Qualcomm Snapdragon X20 LTE-Advanced (CAT16)	M54571-005
	Qualcomm Snapdragon X55 LTE + 5G	M54570-005
<b>(5)</b>	<b>Speaker Kit (left and right)</b>	M35259-001
<b>(6)</b>	<b>System board</b>	
	Includes integrated processor and 16 GB of system memory	M35255-601
	Includes integrated processor and 8 GB of system memory	M35254-601
<b>(7)</b>	<b>Battery</b>	M07392-005
<b>(8)</b>	<b>WWAN antenna, installed in top cover</b>	M35283-001
	Main (4G/5G)	M35272-001
	Aux (4G/5G)	M35273-001
<b>(9)</b>	<b>WWAN antenna bar</b>	
	WWAN	M35283-001
	WLAN	M35284-001
<b>(10)</b>	<b>Touchpad</b>	M35286-001
	<b>NOTE:</b> The touchpad cable is available in the Cable Kit as spare part number M35257-001.	
<b>(11)</b>	<b>Transfer board</b>	
	Privacy models	M35276-001
	Nonprivacy models	M35277-001
<b>(12)</b>	<b>Camera module</b>	M35270-001
<b>(13)</b>	<b>Touch control board</b>	M35278-001
<b>(14)</b>	<b>Jacket assembly</b> (includes the computer cover, hinges and hinge arms, display cables, bezel, hinge cap, rubber support pieces)	M35256-001
<b>(15)</b>	<b>Ambient light sensor</b> (included in Display Cable Kit)	M35258-001
<b>(16)</b>	<b>POGO connector</b> (included in Cable Kit)	M35257-001

**Table 3-1 Computer major component descriptions and part numbers (continued)**

Item	Component	Spare part number
	<b>Top cover with keyboard</b> (not illustrated)	
	<b>NOTE:</b> For a detailed list of country codes, see <a href="#">Top cover with keyboard on page 45</a> .	
	Nonprivacy models	M35264-xx1
	Privacy models	M50327-xx1

## Miscellaneous parts

To identify the miscellaneous parts, use this table.

**Table 3-2 Miscellaneous part descriptions and part numbers**

Component	Spare part number
<b>AC adapter</b> (65 W, nPFC, USB-C, 1.8 m [6.0 ft], slim)	L04650-850
<b>HP Elite Slim Active Pen</b> (includes pen, one dib, and dib removal tool)	M16099-001
<b>Screw Kit</b>	M35267-001
<b>Cable Kit</b> (includes touchpad cable, POGO connector, and pen holder protective tape)	M35257-001
<b>Display Cable Kit</b> (includes camera cable, touch cable, ambient light sensor (ALS) cable, sensor cable, privacy display panel cable, privacy display panel cable for ALS models, and panel and bezel adhesives)	M35258-001
<b>Display Support Kit</b> (includes display adhesives and pen holder protective tape)	M35268-001
<b>Bracket Kit</b> (includes solid-state drive bracket, WWAN module bracket, left USB-C bracket, right USB-C bracket, and pen holder protective tape)	M35271-001
<b>Plastics Kit</b> (includes nano SIM tray, SIM tray insert [for models without WWAN], solid-state drive absorber, camera privacy cover, camera foil, camera mic mesh, and pen holder protective tape)	M35265-001
<b>Rubber Kit</b> (includes display screw protective shielding, camera rubber, mic rubber, top hinge arm protective shielding, bezel rubber, RF connector absorber, system board cable routing rubber, upper lens rubber, support rubber, speaker cable rubber, trunk screw rubber, antenna cable rubber, and pen holder protective tape)	M35266-001
<b>Wireless Bluetooth earbuds</b>	M48196-001
<b>Power cord</b> (C5, premium, 1.0 m [3.3 ft])	
Australia	L22327-001
Denmark	L22322-001
Europe (Austria, Belgium, Finland, France, Germany, the Netherlands, Norway, and Sweden)	L22321-001
Italy	L30813-001
Japan	L22330-001
North America	L22319-001
The People's Republic of China	L21930-001
South Africa	L22325-001
Switzerland	L22324-001

**Table 3-2 Miscellaneous part descriptions and part numbers (continued)**

<b>Component</b>	<b>Spare part number</b>
The United Kingdom	L22320-001
<b>Duckhead power cord</b>	
Japan	L33157-001

---

## 4 Removal and replacement procedures preliminary requirements

Use this information to properly prepare to disassemble and reassemble the computer.

### Tools required

You need the following tools to complete the removal and replacement procedures:

- Tweezers
- Nonconductive, nonmarking pry tool
- Magnetic Phillips P0 screwdriver
- Magnetic Phillips P1 screwdriver
- Suction cup
- Metal hook tool

### Service considerations

The following sections include some of the considerations that you must keep in mind during disassembly and assembly procedures.



---

**NOTE:** As you remove each subassembly from the computer, place the subassembly (and all accompanying screws) away from the work area to prevent damage.

---

### Plastic parts

Using excessive force during disassembly and reassembly can damage plastic parts.

### Cables and connectors

Handle cables with extreme care to avoid damage.



---

**IMPORTANT:** When servicing the computer, be sure that cables are placed in their proper locations during the reassembly process. Improper cable placement can damage the computer.

---

Apply only the tension required to unseat or seat the cables during removal and insertion. Handle cables by the connector whenever possible. In all cases, avoid bending, twisting, or tearing cables. Be sure that cables are routed so that they cannot be caught or snagged as you remove or replace parts. Handle flex cables with extreme care; these cables tear easily.

### Drive handling

Note the following guidelines when handling drives.

---

 **IMPORTANT:** Drives are fragile components. Handle them with care. To prevent damage to the computer, damage to a drive, or loss of information, observe these precautions:

Before removing or inserting a hard drive, shut down the computer. If you are unsure whether the computer is off or in Hibernation, turn the computer on, and then shut it down through the operating system.

Before handling a drive, be sure that you are discharged of static electricity. While handling a drive, avoid touching the connector.

Before removing an optical drive, be sure that a disc is not in the drive, and be sure that the optical drive tray is closed.

Handle drives on surfaces covered with at least 2.54 cm (1 inch) of shock-proof foam.

Avoid dropping drives from any height onto any surface.

After removing a hard drive or an optical drive, place it in a static-proof bag.

Avoid exposing an internal hard drive to products that have magnetic fields, such as monitors or speakers.

Avoid exposing a drive to temperature extremes or liquids.

If a drive must be mailed, place the drive in a bubble pack mailer or other suitable form of protective packaging, and label the package "FRAGILE."

---

## Electrostatic discharge information

A sudden discharge of static electricity from your finger or other conductor can destroy static-sensitive devices or microcircuitry. Often the spark is neither felt nor heard, but damage occurs. An electronic device exposed to electrostatic discharge (ESD) might not appear to be affected at all and can work perfectly throughout a normal cycle. The device might function normally for a while, but it has been degraded in the internal layers, reducing its life expectancy.

Networks built into many integrated circuits provide some protection, but in many cases, the discharge contains enough power to alter device parameters or melt silicon junctions.

---

 **IMPORTANT:** To prevent damage to the device when you remove or install internal components, observe these precautions:

Keep components in their electrostatic-safe containers until you are ready to install them.

Before touching an electronic component, discharge static electricity by using the guidelines described [Personal grounding methods and equipment on page 22](#).

Avoid touching pins, leads, and circuitry. Handle electronic components as little as possible.

If you remove a component, place it in an electrostatic-safe container.

---

## Generating static electricity

Follow these static electricity guidelines.

- Different activities generate different amounts of static electricity.
- Static electricity increases as humidity decreases.

**Table 4-1 Static electricity occurrence based on activity and humidity**

Event	Relative humidity		
	55%	40%	10%
Walking across carpet	7,500 V	15,000 V	35,000 V

**Table 4-1 Static electricity occurrence based on activity and humidity (continued)**

	Relative humidity		
Walking across vinyl floor	3,000 V	5,000 V	12,000 V
Motions of bench worker	400 V	800 V	6,000 V
Removing DIPs (dual in-line packages) from plastic tube	400 V	700 V	2,000 V
Removing DIPs from vinyl tray	2,000 V	4,000 V	11,500 V
Removing DIPs from polystyrene foam	3,500 V	5,000 V	14,500 V
Removing bubble pack from PCB (printed circuit board)	7,000 V	20,000 V	26,500 V
Packing PCBs in foam-lined box	5,000 V	11,000 V	21,000 V

Multiple electric components can be packaged together in plastic tubes, trays, or polystyrene foam.



**NOTE:** As little as 700 V can degrade a product.

## Preventing electrostatic damage to equipment

Many electronic components are sensitive to ESD. Circuitry design and structure determine the degree of sensitivity. The following packaging and grounding precautions are necessary to prevent static electricity damage to electronic components.

- To avoid hand contact, transport products in static-safe containers such as tubes, bags, or boxes.
- Protect all electrostatic parts and assemblies with conductive or approved containers or packaging.
- Keep electrostatic-sensitive parts in their containers until they arrive at static-free stations.
- Place items on a grounded surface before removing them from their container.
- Always be properly grounded when touching a sensitive component or assembly.
- Avoid contact with pins, leads, or circuitry.
- Place reusable electrostatic-sensitive parts from assemblies in protective packaging or conductive foam.

## Personal grounding methods and equipment

Using certain equipment can prevent static electricity damage to electronic components.

- **Wrist straps** are flexible straps with a maximum of 1 M $\Omega$   $\pm$ 10% resistance in the ground cords. To provide proper ground, a strap must be worn snug against bare skin. The ground cord must be connected and fit snugly into the banana plug connector on the grounding mat or workstation.
- **Heel straps/Toe straps/Boot straps** can be used at standing workstations and are compatible with most types of shoes or boots. On conductive floors or dissipative floor mats, use them on both feet with a maximum of 1 M $\Omega$   $\pm$ 10% resistance between the operator and ground.

**Table 4-2 Static shielding protection levels**

Static shielding protection levels	
Method	Voltage
Antistatic plastic	1,500

**Table 4-2 Static shielding protection levels (continued)**

Static shielding protection levels	
Carbon-loaded plastic	7,500
Metallized laminate	15,000

## Grounding the work area

To prevent static damage at the work area, follow these precautions.

- Cover the work surface with approved static-dissipative material.
- Use a wrist strap connected to a properly grounded work surface and use properly grounded tools and equipment.
- Use static-dissipative mats, foot straps, or air ionizers to give added protection.
- Handle electrostatic sensitive components, parts, and assemblies by the case or PCB laminate. Handle them only at static-free work areas.
- Turn off power and input signals before inserting and removing connectors or test equipment.
- Use fixtures made of static-safe materials when fixtures must directly contact dissipative surfaces.
- Keep the work area free of nonconductive materials, such as ordinary plastic assembly aids and polystyrene foam.
- Use conductive field service tools, such as cutters, screwdrivers, and vacuums.
- Avoid contact with pins, leads, or circuitry.

## Recommended materials and equipment

HP recommends certain materials and equipment to prevent static electricity.

- Antistatic tape
- Antistatic smocks, aprons, or sleeve protectors
- Conductive bins and other assembly or soldering aids
- Conductive foam
- Conductive tabletop workstations with ground cord of  $1\text{ M}\Omega \pm 10\%$  resistance
- Static-dissipative table or floor mats with hard tie to ground
- Field service kits
- Static awareness labels
- Wrist straps and footwear straps providing  $1\text{ M}\Omega \pm 10\%$  resistance
- Material handling packages
- Conductive plastic bags
- Conductive plastic tubes
- Conductive tote boxes
- Opaque shielding bags

- Transparent metallized shielding bags
- Transparent shielding tubes

## Cleaning your computer

Cleaning your computer regularly removes dirt and debris so that your device continues to operate at its best. Use the following information to safely clean the external surfaces of your computer.

### Enabling HP Easy Clean (select products only)

HP Easy Clean helps you to avoid accidental input while you clean the computer surfaces. This software disables devices such as the keyboard, touch screen, and touchpad for a preset amount of time so that you can clean all computer surfaces.

1. Start HP Easy Clean in one of the following ways:
  - Select the **Start** menu, and then select **HP Easy Clean**.
    - or –
  - Select the **HP Easy Clean** icon in the taskbar.
    - or –
  - Select **Start**, and then select the **HP Easy Clean** tile.
2. Now that your device is disabled for a short period, see [Removing dirt and debris from your computer on page 24](#) for the recommended steps to clean the high-touch, external surfaces on your computer. After you remove the dirt and debris, you can also clean the surfaces with a disinfectant. See [Cleaning your computer with a disinfectant on page 25](#) for guidelines to help prevent the spread of harmful bacteria and viruses.

### Removing dirt and debris from your computer

Here are the recommended steps to clean dirt and debris from your computer.

For computers with wood veneer, see [Caring for wood veneer \(select products only\) on page 26](#).

1. Wear disposable gloves made of latex (or nitrile gloves, if you are latex-sensitive) when cleaning the surfaces.
2. Turn off your device and unplug the power cord and other connected external devices. Remove any installed batteries from items such as wireless keyboards.

---

 **CAUTION:** To prevent electric shock or damage to components, never clean a product while it is turned on or plugged in.

---

3. Moisten a microfiber cloth with water. The cloth should be moist, but not dripping wet.

---

 **IMPORTANT:** To avoid damaging the surface, avoid abrasive cloths, towels, and paper towels.

---

4. Wipe the exterior of the product gently with the moistened cloth.

---

 **IMPORTANT:** Keep liquids away from the product. Avoid getting moisture in any openings. If liquid makes its way inside your HP product, it can cause damage to the product. Do not spray liquids directly on the product. Do not use aerosol sprays, solvents, abrasives, or cleaners containing hydrogen peroxide or bleach that might damage the finish.

---



5. Start with the display (if applicable). Wipe carefully in one direction, and move from the top of the display to the bottom. Finish with any flexible cables, like power cord, keyboard cable, and USB cables.
6. Be sure that surfaces have completely air-dried before turning the device on after cleaning.
7. Discard the gloves after each cleaning. Clean your hands immediately after you remove the gloves.

See [Cleaning your computer with a disinfectant on page 25](#) for recommended steps to clean the high-touch, external surfaces on your computer to help prevent the spread of harmful bacteria and viruses.

## Cleaning your computer with a disinfectant

The World Health Organization (WHO) recommends cleaning surfaces, followed by disinfection, as a best practice for preventing the spread of viral respiratory illnesses and harmful bacteria.

After cleaning the external surfaces of your computer using the steps in [Removing dirt and debris from your computer on page 24](#), [Caring for wood veneer \(select products only\) on page 26](#), or both, you might also choose to clean the surfaces with a disinfectant. A disinfectant that is within HP's cleaning guidelines is an alcohol solution consisting of 70% isopropyl alcohol and 30% water. This solution is also known as rubbing alcohol and is sold in most stores.

Follow these steps when disinfecting high-touch, external surfaces on your computer:

1. Wear disposable gloves made of latex (or nitrile gloves, if you are latex-sensitive) when cleaning the surfaces.
2. Turn off your device and unplug the power cord and other connected external devices. Remove any installed batteries from items such as wireless keyboards.

---

 **CAUTION:** To prevent electric shock or damage to components, never clean a product while it is turned on or plugged in.

---

3. Moisten a microfiber cloth with a mixture of 70% isopropyl alcohol and 30% water. The cloth should be moist, but not dripping wet.

---

 **CAUTION:** Do not use any of the following chemicals or any solutions that contain them, including spray-based surface cleaners: bleach, peroxides (including hydrogen peroxide), acetone, ammonia, ethyl alcohol, methylene chloride, or any petroleum-based materials, such as gasoline, paint thinner, benzene, or toluene.

---

 **IMPORTANT:** To avoid damaging the surface, avoid abrasive cloths, towels, and paper towels.

---

4. Wipe the exterior of the product gently with the moistened cloth.

---

 **IMPORTANT:** Keep liquids away from the product. Avoid getting moisture in any openings. If liquid makes its way inside your HP product, it can cause damage to the product. Do not spray liquids directly on the product. Do not use aerosol sprays, solvents, abrasives, or cleaners containing hydrogen peroxide or bleach that might damage the finish.

---

5. Start with the display (if applicable). Wipe carefully in one direction, and move from the top of the display to the bottom. Finish with any flexible cables, like power cord, keyboard cable, and USB cables.
6. Be sure that surfaces have completely air-dried before turning the device on after cleaning.
7. Discard the gloves after each cleaning. Clean your hands immediately after you remove the gloves.

## Caring for wood veneer (select products only)

Your product might feature high-quality wood veneer. As with all natural wood products, proper care is important for best results over the life of the product. Because of the nature of natural wood, you might see unique variations in the grain pattern or subtle variations in color, which are normal.

- Clean the wood with a dry, static-free microfiber cloth or chamois.
- Avoid cleaning products containing substances such as ammonia, methylene chloride, acetone, turpentine, or other petroleum-based solvents.
- Do not expose the wood to sun or moisture for long periods of time.
- If the wood becomes wet, dry it by dabbing with an absorbent, lint-free cloth.
- Avoid contact with any substance that might dye or discolor the wood.
- Avoid contact with sharp objects or rough surfaces that might scratch the wood.

See [Removing dirt and debris from your computer on page 24](#) for the recommended steps to clean the high-touch, external surfaces on your computer. After you remove the dirt and debris, you can also clean the surfaces with a disinfectant. See [Cleaning your computer with a disinfectant on page 25](#) for sanitizing guidelines to help prevent the spread of harmful bacteria and viruses.

## Packaging and transporting guidelines

Follow these grounding guidelines when packaging and transporting equipment.

- To avoid hand contact, transport products in static-safe tubes, bags, or boxes.
- Protect ESD-sensitive parts and assemblies with conductive or approved containers or packaging.
- Keep ESD-sensitive parts in their containers until the parts arrive at static-free workstations.
- Place items on a grounded surface before removing items from their containers.
- Always be properly grounded when touching a component or assembly.
- Store reusable ESD-sensitive parts from assemblies in protective packaging or nonconductive foam.
- Use transporters and conveyors made of antistatic belts and roller bushings. Be sure that mechanized equipment used for moving materials is wired to ground and that proper materials are selected to avoid static charging. When grounding is not possible, use an ionizer to dissipate electric charges.

## Accessing support information

Use this information to find the HP support that you need.

**Table 4-3 Support information locations**

Service consideration	Path to access information
Technical bulletins	To locate technical bulletins: <ol style="list-style-type: none"><li>1. Go to <a href="http://www.hp.com">www.hp.com</a>.</li><li>2. Place the cursor over <b>Problem solving</b> to display more options.</li><li>3. Select <b>Support &amp; Troubleshooting</b>.</li><li>4. Type the serial number, product number, or product name to go to the product support page.</li></ol>

**Table 4-3 Support information locations (continued)**

Service consideration	Path to access information
Repair professionals	<p data-bbox="703 264 1147 285">5. Select <b>Advisories</b> to view technical bulletins.</p> <p data-bbox="703 310 970 331">To locate repair professionals:</p> <ol data-bbox="703 359 1331 470" style="list-style-type: none"><li data-bbox="703 359 922 380">1. Go to <a href="http://www.hp.com">www.hp.com</a>.</li><li data-bbox="703 405 1331 426">2. Place the cursor over <b>Support resources</b> to display more options.</li><li data-bbox="703 451 1082 472">3. Select <b>Authorized service providers</b>.</li></ol>
Component and diagnosis information, failure detection, and required action	<p data-bbox="703 497 1094 518">To locate diagnosis information and actions:</p> <ol data-bbox="703 543 1401 680" style="list-style-type: none"><li data-bbox="703 543 1187 564">1. Go to <a href="http://www.hp.com/go/techcenter/pcdiags">http://www.hp.com/go/techcenter/pcdiags</a>.</li><li data-bbox="703 590 927 611">2. Select <b>Get Support</b>.</li><li data-bbox="703 636 1401 680">3. Near the bottom of the window, select <b>Notebook PCs</b>, and the select your location.</li></ol>

# 5 Removal and replacement procedures for Customer Self-Repair parts

This chapter provides removal and replacement procedures for Customer Self-Repair parts.

 **NOTE:** The Customer Self-Repair program is not available in all locations. Installing a part that is not supported by the Customer Self-Repair program can void your warranty. Check your warranty to determine whether Customer Self-Repair is supported in your location.

## Component replacement procedures

To remove and replace computer components, use these procedures.

 **NOTE:** Details about your computer, including model, serial number, product key, and length of warranty, are on the service tag at the bottom of your computer.

 **NOTE:** HP continually improves and changes product parts. For complete and current information about supported parts for your computer, go to <http://partsurfer.hp.com>, select your country or region, and then follow the on-screen instructions.

You must remove, replace, or loosen as many as xx screws when you service Customer Self-Repair parts. Make special note of each screw size and location during removal and replacement.

## Preparation for disassembly

To prepare to disassemble the computer, use these steps.

See [Removal and replacement procedures preliminary requirements on page 20](#) for initial safety procedures.

1. Turn off the computer. If you are unsure whether the computer is off or in Hibernation, turn the computer on, and then shut it down through the operating system.
2. Disconnect the power from the computer by unplugging the power cord from the computer.
3. Disconnect all external devices from the computer.

## Pen

To remove the pen, use this procedure and illustration.

**Table 5-1 Pen description and part number**

Description	Spare part number
Pen	M16099-001

Before removing the pen, follow these steps:

- ▲ Prepare the computer for disassembly (see [Preparation for disassembly on page 28](#)).

Remove the pen:

- ▲ Lift the pen out of the holder above the keyboard.

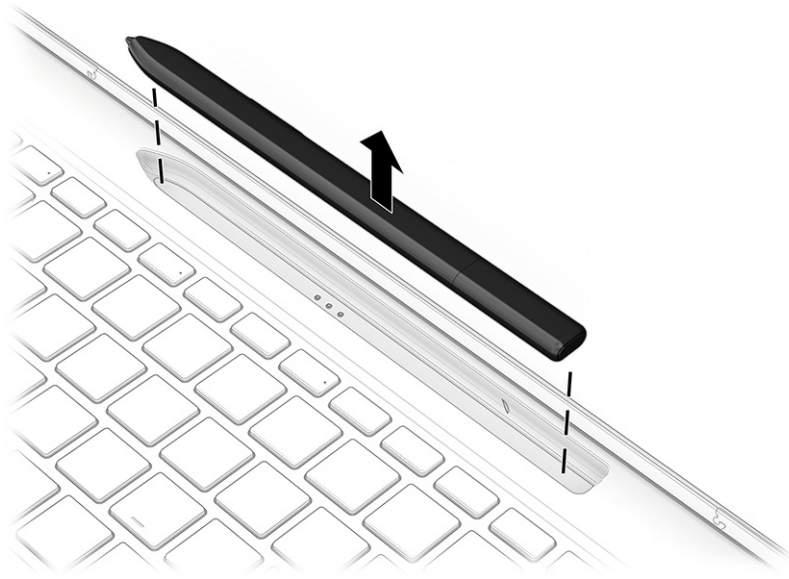



Reverse this procedure to install the pen.

---

## 6 Removal and replacement procedures for authorized service provider parts

This chapter provides removal and replacement procedures for authorized service provider parts.

 **IMPORTANT:** Components described in this chapter should be accessed only by an authorized service provider. Accessing these parts can damage the computer or void the warranty.

 **NOTE:** Details about your computer, including model, serial number, product key, and length of warranty, are on the service tag at the bottom of your computer.

---

### Component replacement procedures

To remove and replace computer components, use these procedures.

 **NOTE:** HP continually improves and changes product parts. For complete and current information about supported parts for your computer, go to <http://partsurfer.hp.com>, select your country or region, and then follow the on-screen instructions.

---

You must remove, replace, or loosen as many as 82 screws when you service the parts described in this chapter. Make special note of each screw size and location during removal and replacement.

### Bottom cover

You cannot completely remove the bottom cover, as it remains connected to the computer during disassembly. You have to loosen the bottom cover and place it next to the computer so you can access internal components.

Before loosening the bottom cover, follow these steps:

1. Prepare the computer for disassembly (see [Preparation for disassembly on page 28](#)).
2. Remove the pen (see [Pen on page 28](#)).

Loosen the bottom cover:

1. Using tweezers, pull up the right side of the protective strip from the pen holder **(1)**, and then remove the strip **(2)**. A new protective strip is provided.

 **NOTE:** Be careful not to scratch the pen housing.

---

2. Remove the four Phillips M1.4 × 2.0 screws (3) that secure the bottom cover to the computer.

 **NOTE:** Be careful not to strip the screws.



3. Slide the bottom cover toward the hinges (1), and then lift the cover and place it next to the computer (2).

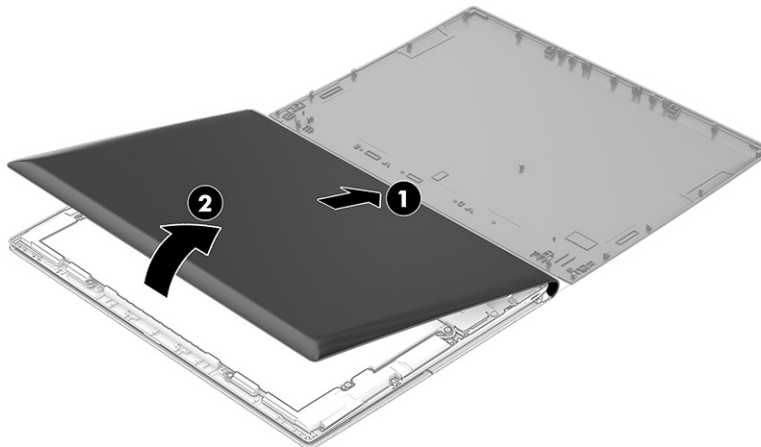

To replace the bottom cover, reverse the removal procedures.

## Battery

To remove the battery, use this procedure and illustration.

**Table 6-1** Battery description and part number

Description	Spare part number
Battery, 4 cell, 46 Whr	M07392-005

---

**⚠ WARNING!** To avoid personal injury and damage to the product:

- Do *not* puncture, twist, or crack the battery.
  - Do *not* cause an external puncture or rupture to the battery. They can cause a short inside the battery, which can result in battery thermal runaway.
  - Do *not* handle or touch the battery enclosure with sharp objects such as tweezers or pliers, which might puncture the battery.
  - Do *not* compress or squeeze the battery case with tools or heavy objects stacked on top of the case. These actions can apply undue force on the battery.
  - Do *not* touch the connectors with any metallic surface or object, such as metal tools, screws, or coins, which can cause shorting across the connectors.
- 

Before removing the battery, follow these steps:

1. Prepare the computer for disassembly (see [Preparation for disassembly on page 28](#)).
  2. Remove the pen (see [Pen on page 28](#)).
  3. Remove the bottom cover (see [Bottom cover on page 30](#)).
- 

**⚠ WARNING!** To reduce potential safety issues, use only the user-replaceable battery provided with the computer, a replacement battery provided by HP, or a compatible battery purchased from HP.

**📄 IMPORTANT:** Removing a battery that is the sole power source for the computer can cause loss of information. To prevent loss of information, save your work or shut down the computer through Windows before you remove the battery.

---

Remove the battery:

1. Disconnect the battery cable from the system board **(1)**.
2. Remove the four Phillips M2.0 × 3.0 screws **(2)** that secure the battery to the computer.
3. Remove the Phillips M1.4 × 2.0 screw **(3)** that secures the battery to the computer.
4. If installed, remove the tape that secures the antenna cable to the battery.
5. Remove the battery from the computer **(4)**.

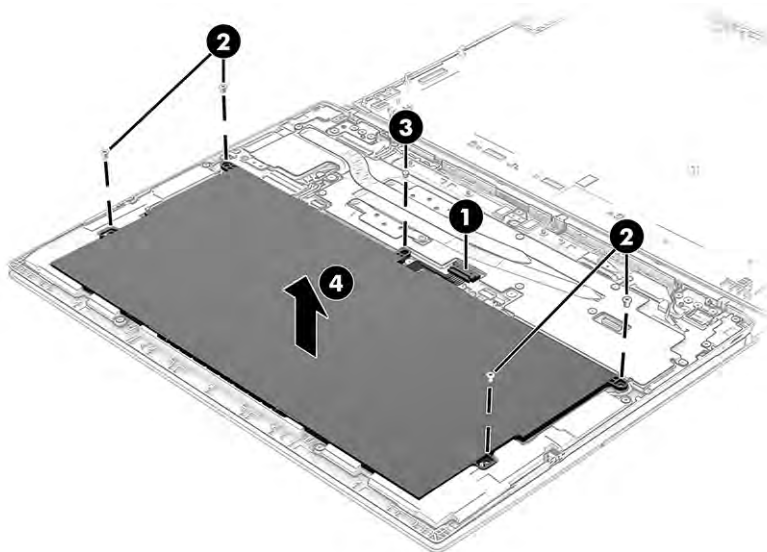



To insert the battery, reverse the removal procedures.

## Speakers

To remove the speakers, use this procedure and illustration.

**Table 6-2 Speakers description and part number**

Description	Spare part number
Speakers	M35259-001

Before removing the speakers, follow these steps:

1. Prepare the computer for disassembly (see [Preparation for disassembly on page 28](#)).
2. Remove the pen (see [Pen on page 28](#)).
3. Remove the bottom cover (see [Bottom cover on page 30](#)).
4. Remove the battery (see [Battery on page 31](#)).

Remove the speakers:

1. Disconnect the right speaker cable from the system board **(1)**.



**NOTE:** If tape is holding the cables in place, gently pull up and reuse the tape when reassembling the speakers.

2. Remove the antenna cable from its routing path near the right speaker **(2)**.



**NOTE:** You must pull the WWAN antenna cables and tape up and left before you can remove the left speaker cable.

3. Disconnect the left speaker cable from the system board **(3)**.
4. Remove the right speaker cable from the channel below the system board **(4)**.
5. Remove the two Phillips M1.4 × 1.2 screw **(5)** from each speaker.

6. Remove the speakers from the computer **(6)**.

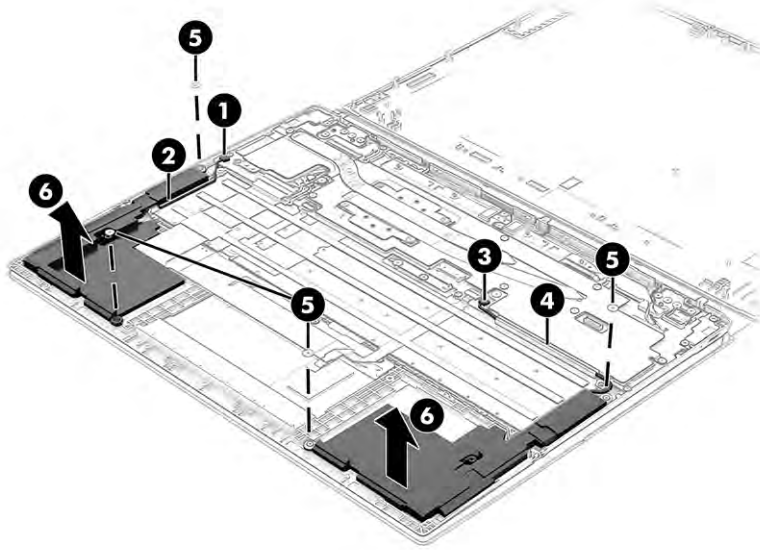

Reverse this procedure to install the speakers.



**NOTE:** When installing the speakers, be sure rubber grommets are installed in the screw holes in the speakers.

## Touchpad

To remove the touchpad, use this procedure and illustration.

**Table 6-3 Touchpad description and part number**

Description	Spare part number
Touchpad	M35286-001
Touchpad cable (included in Cable Kit)	M35257-001

Before removing the touchpad, follow these steps:

1. Prepare the computer for disassembly (see [Preparation for disassembly on page 28](#)).
2. Remove the pen (see [Pen on page 28](#)).
3. Remove the bottom cover (see [Bottom cover on page 30](#)).
4. Remove the battery (see [Battery on page 31](#)).

Remove the touchpad:

1. Disconnect the touchpad cable from the touchpad ZIF connector **(1)**.
2. Gently pull up to release the keyboard cable from the adhesive that secures it to the top of the touchpad **(2)**.



**NOTE:** To prevent damage to the cable, be careful not to use too much force when releasing the keyboard cable.

3. Remove the three Phillips M2.0 × 2.0 screws **(3)** that secure the touchpad to the computer.
4. Rotate the touchpad upward to a 20° to 30° angle **(4)**, and then pull the touchpad away from the computer at an angle to remove it **(5)**.

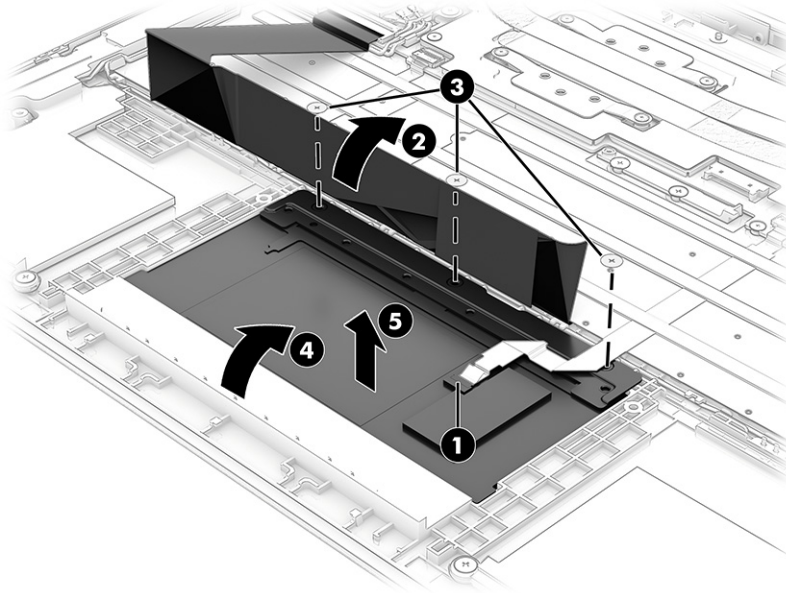

Reverse this procedure to install the touchpad.

 **IMPORTANT:** To avoid damaging the display during touchpad installation, before inserting the touchpad into the computer, lift the top cover/keyboard up off the display.

## Wireless antennas and cables (installed on top cover)

To remove the wireless antennas and cables that are installed on the top cover, use this procedure and illustration.

**Table 6-4 Wireless antennas and cables description and part number**

Description	Spare part number
Wireless antennas and cables (main)	M35272-001
Wireless antennas and cables (aux)	M35273-001

Before removing the wireless antennas and cables, follow these steps:

1. Prepare the computer for disassembly (see [Preparation for disassembly on page 28](#)).
2. Remove the pen (see [Pen on page 28](#)).
3. Remove the bottom cover (see [Bottom cover on page 30](#)).
4. Remove the battery (see [Battery on page 31](#)).

Remove the wireless antennas and cables:

1. Disconnect the antenna cables from the WLAN module **(1)**.
2. Remove the cables from their routing under the keyboard cable and around to the left antenna **(2)**.

3. Lift the keyboard cable off the top of the touchpad **(3)**.
4. Peel the right and left antennas off the computer **(4)**.
5. Remove the antenna cable from its routing above the touchpad **(5)**.

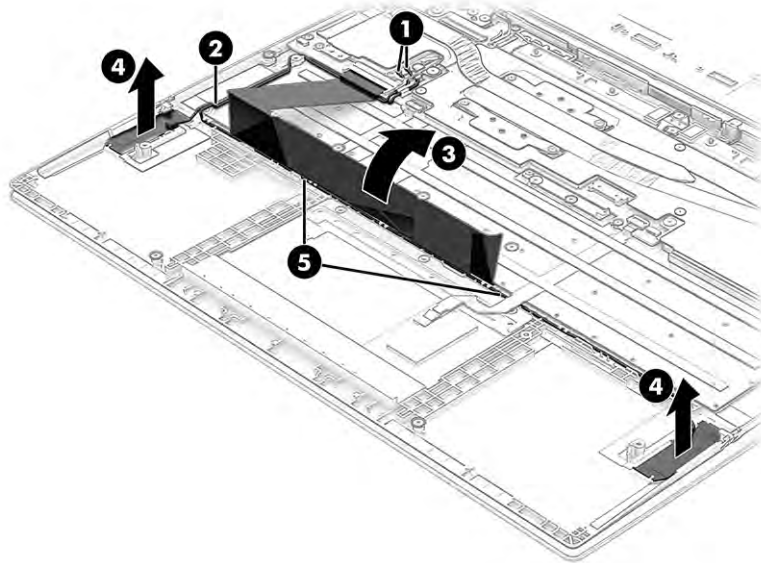

Reverse this procedure to install the wireless antennas and cables.

## Heat sink

To remove the heat sink, use this procedure and illustration.

**Table 6-5 Heat sink description and part number**

Description	Spare part number
Heat sink	M35260-001
Heat sink thermal pad kit	M42820-001

Before removing the heat sink, follow these steps:

1. Prepare the computer for disassembly (see [Preparation for disassembly on page 28](#)).
2. Remove the pen (see [Pen on page 28](#)).
3. Remove the bottom cover (see [Bottom cover on page 30](#)).
4. Disconnect the battery cable from the system board (see [Battery on page 31](#)).

Remove the heat sink:

1. In the order indicated on the heat sink, loosen the 12 captive Phillips screws **(1)** that secure the heat sink to the computer.

- Remove the heat sink from the computer (2).

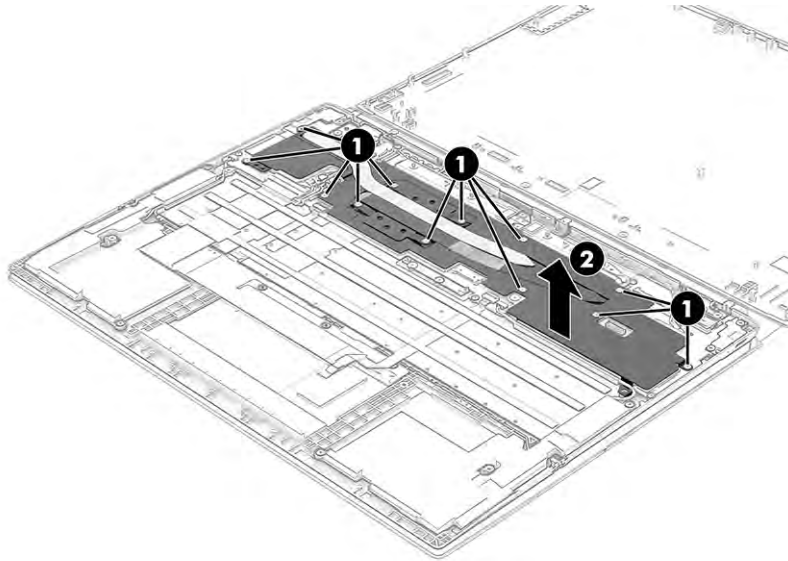

- Thoroughly clean the thermal material from the surfaces of the heat sink and the system board components each time the heat sink is removed. Replacement thermal material is included with the heat sink and system board spare part kits. The following illustration shows the replacement thermal material locations.

Thermal grease is used in one location on the heat sink (1). Thermal pads are used in six locations on the heat sink (2).

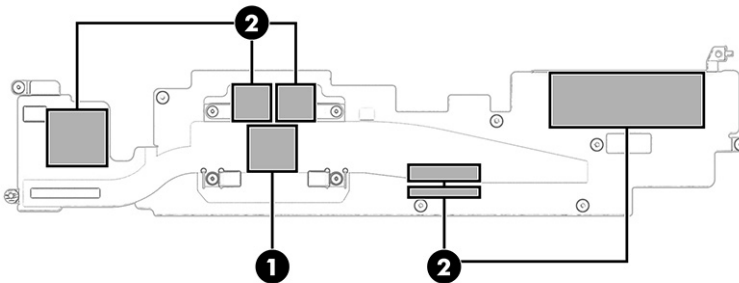

Reverse this procedure to install the heat sink.

## Solid-state drive

To remove the M.2 solid-state drive, use this procedure and illustration.

**Table 6-6 Solid-state drive descriptions and part numbers**

Description	Spare part number
512 GB, PCIe-3 × 4, TLC	M54568-005
256 GB, PCIe-3 × 4, TLC	M54567-005
128 GB, PCIe-3 × 2, TLC	M54569-005

Before removing the solid-state drive, follow these steps:

1. Prepare the computer for disassembly (see [Preparation for disassembly on page 28](#)).
2. Remove the pen (see [Pen on page 28](#)).
3. Remove the bottom cover (see [Bottom cover on page 30](#)).
4. Disconnect the battery cable from the system board (see [Battery on page 31](#)).
5. Remove the heat sink (see [Heat sink on page 36](#)).

Remove the solid-state drive:

1. Remove the Phillips M1.4 × 1.2 screw **(1)** that secures the drive to the computer.
2. Pull the drive away from the socket to remove it **(2)**.

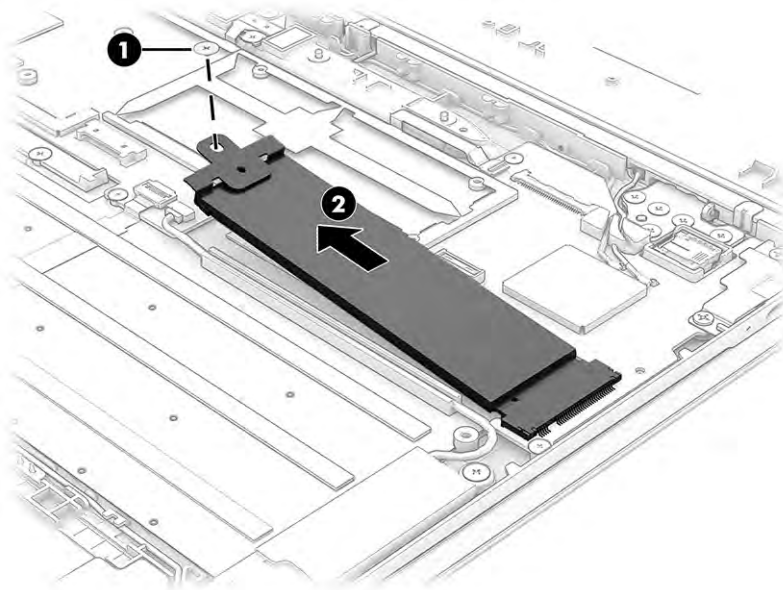

3. To remove the bracket from the solid-state drive, remove the Phillips M1.4 × 1.2 screw **(1)** that secures the bracket to the drive, and then remove the bracket from the drive **(2)**. Install the bracket on the new solid-state drive.

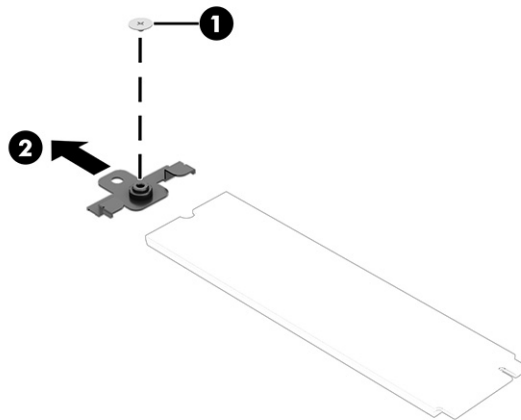

To install the solid-state drive, reverse the removal procedures.



**NOTE:** Solid-state drives are designed with a notch to prevent incorrect insertion.

## WWAN module

To remove the WWAN module, use this procedure and illustration.

**Table 6-7 WWAN module descriptions and part numbers**

Description	Spare part number
Qualcomm Snapdragon X55 LTE + 5G	M54570-005
Qualcomm Snapdragon X20 LTE - Advanced Pro (Cat16)	M54571-005



**IMPORTANT:** To prevent an unresponsive system, replace the wireless module only with a wireless module authorized for use in the computer by the governmental agency that regulates wireless devices in your country or region. If you replace the module and then receive a warning message, remove the module to restore device functionality, and then contact technical support.

Before removing the WWAN module, follow these steps:

1. Prepare the computer for disassembly (see [Preparation for disassembly on page 28](#)).
2. Remove the pen (see [Pen on page 28](#)).
3. Remove the bottom cover (see [Bottom cover on page 30](#)).
4. Disconnect the battery cable from the system board (see [Battery on page 31](#)).
5. Remove the heat sink (see [Heat sink on page 36](#)).

Remove the WWAN module:

1. Carefully disconnect the antenna cables from the module **(1)**.



**NOTE:** Be sure to save the foam that is removed when you disconnect the antennas and replace it on the antennas when installing a WWAN module.



2. Remove the Phillips M1.4 × 1.2 screw (2), and then remove the WWAN module (3).

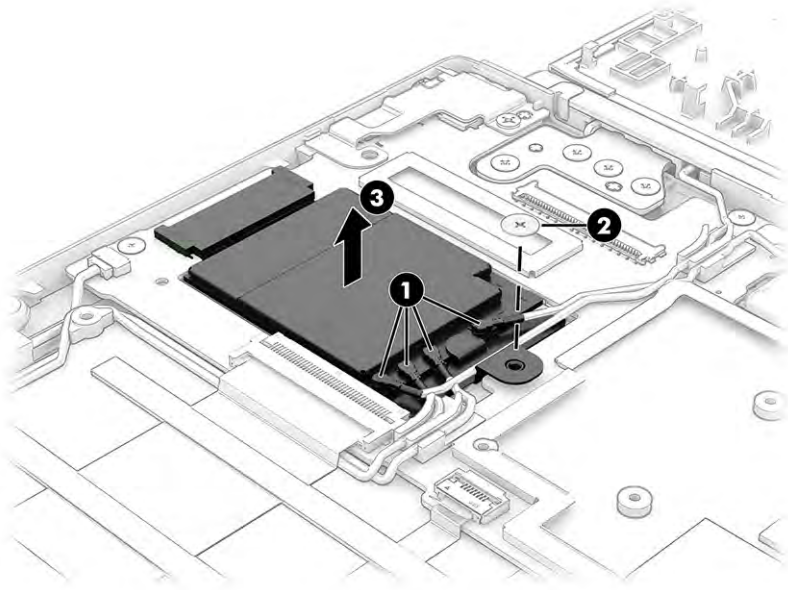

3. Pull the bracket off the old WWAN module and install the bracket on the new module.

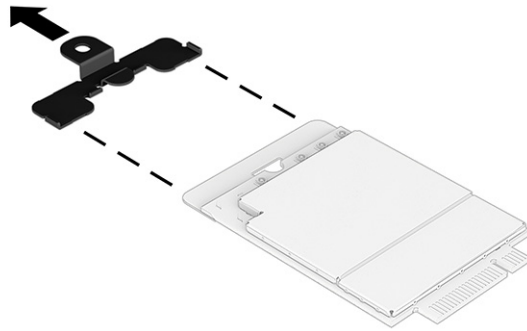



4. If the WWAN antenna is not connected to the terminal on the WWAN module, install a protective sleeve on the antenna connector, as shown in the following illustration.

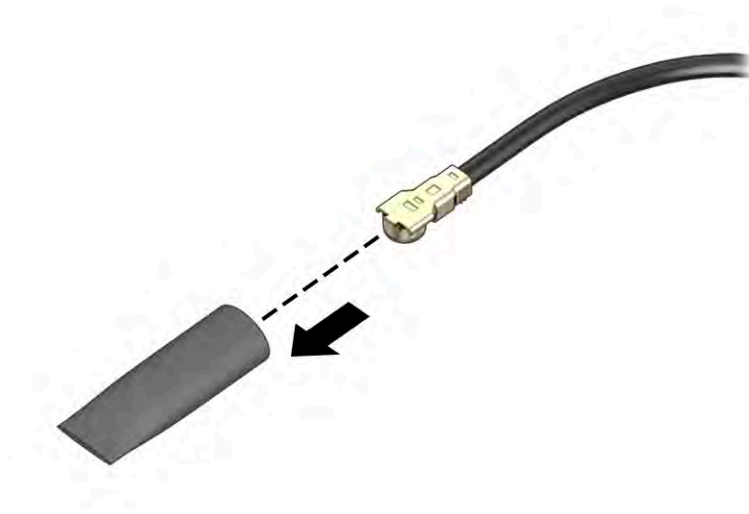

Reverse this procedure to install the WWAN module.

## System board

To remove the system board, use these procedures and illustrations.

**Table 6-8 System board descriptions and part numbers**

Description	Spare part number
<b>System board</b>	
Includes integrated processor and 16 GB of system memory	M35255-601
Includes integrated processor and 8 GB of system memory	M35254-601

Before removing the system board, follow these steps:

1. Prepare the computer for disassembly (see [Preparation for disassembly on page 28](#)).
2. Remove the pen (see [Pen on page 28](#)).
3. Remove the bottom cover (see [Bottom cover on page 30](#)).
4. Remove the battery (see [Battery on page 31](#)).
5. Remove the heat sink (see [Heat sink on page 36](#)).
6. Remove the solid-state drive (see [Solid-state drive on page 37](#)).

Remove the system board:

1. Disconnect the following cables from the system board:
  - WWAN antennas from the WWAN module **(1)**
  - Display cable **(2)**
  - POGO cable (ZIF) **(3)**

- Display cable **(4)**
- WLAN antennas **(5)**
- Speaker cable **(6)**
- Touchpad cable (ZIF) **(7)**
- Keyboard backlight cable **(8)**
- Keyboard cable (ZIF) **(9)**
- Speaker cable **(10)**

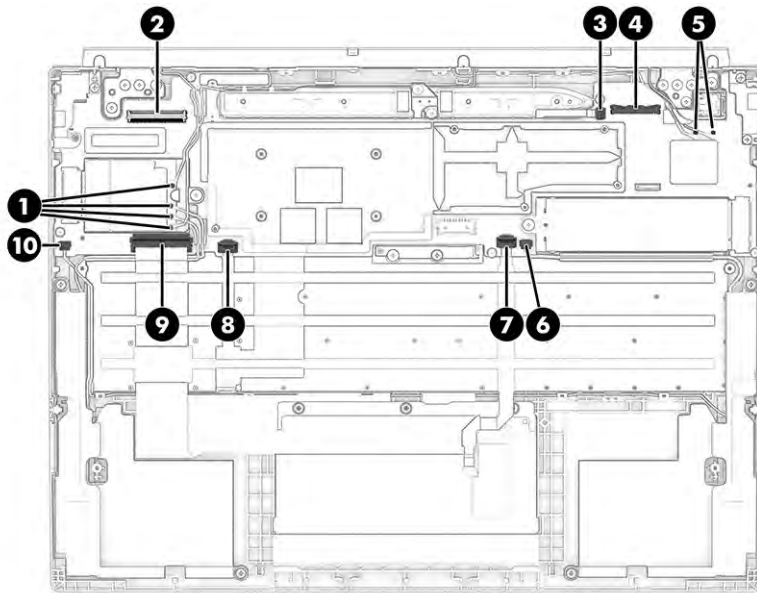

2. Remove the SIM card holder from the SIM slot under the pen.

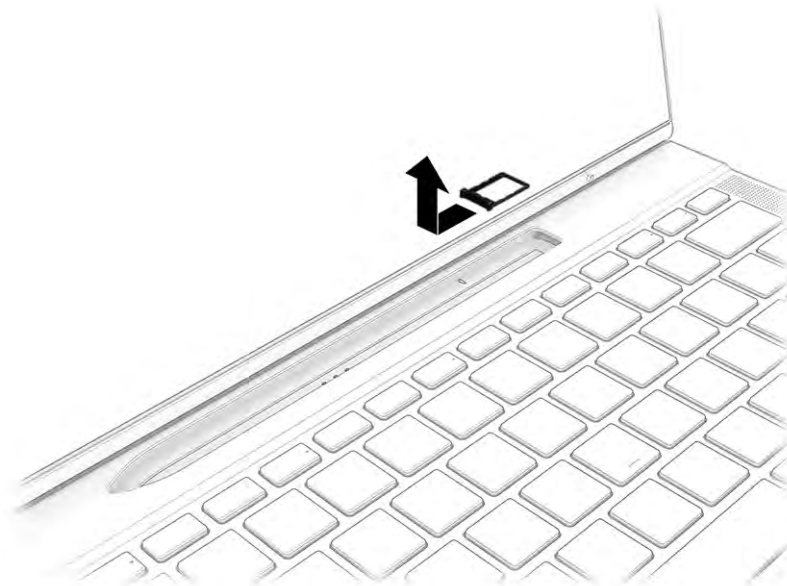

3. Remove the three Phillips M2.0 × 3.0 screws **(1)** that secure the brackets to each side of the system board.

4. Remove the brackets **(2)**.
5. Remove the five Phillips M1.4 × 2.0 screws **(3)** that secure the system board to the computer.

 **NOTE:** If a screw is covered by protective tape, gently pull the tape up to access the screw.

6. Lift the right side of the system board up **(4)**, and then pull the system board toward the right and out of the computer **(5)**.

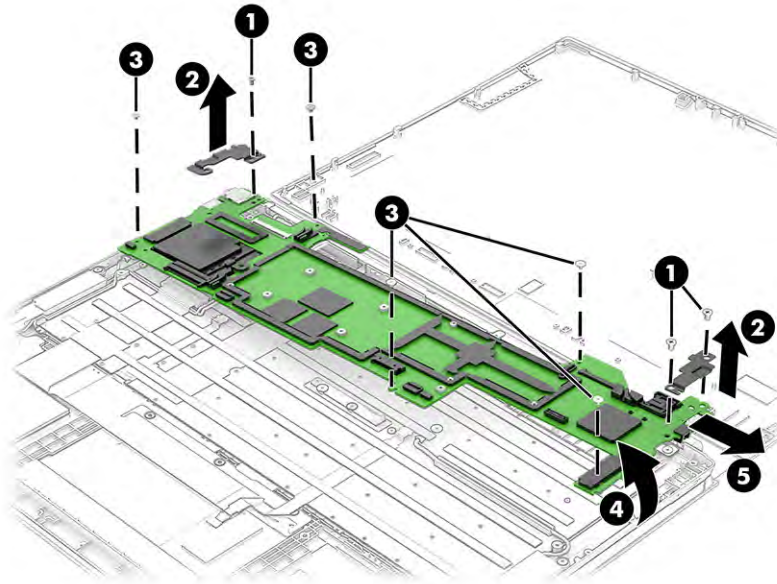

Reverse this procedure to install the system board.

## POGO connector

To remove the POGO connector, use this procedure and illustration.

**Table 6-9 POGO connector description and part number**

Description	Spare part number
POGO connector (included in the Cable Kit)	M35257-001

Before removing the POGO connector, follow these steps:

1. Prepare the computer for disassembly (see [Preparation for disassembly on page 28](#)).
2. Remove the pen (see [Pen on page 28](#)).
3. Remove the bottom cover (see [Bottom cover on page 30](#)).
4. Remove the battery (see [Battery on page 31](#)).
5. Remove the heat sink (see [Heat sink on page 36](#)).
6. Remove the solid-state drive (see [Solid-state drive on page 37](#)).

Remove the POGO connector:

1. Remove the two Phillips M1.4 × 1.2 screws **(1)** that secure the POGO connector to the computer.

2. Peel the cable off the computer **(2)**. The cable is secured to the computer with adhesive.

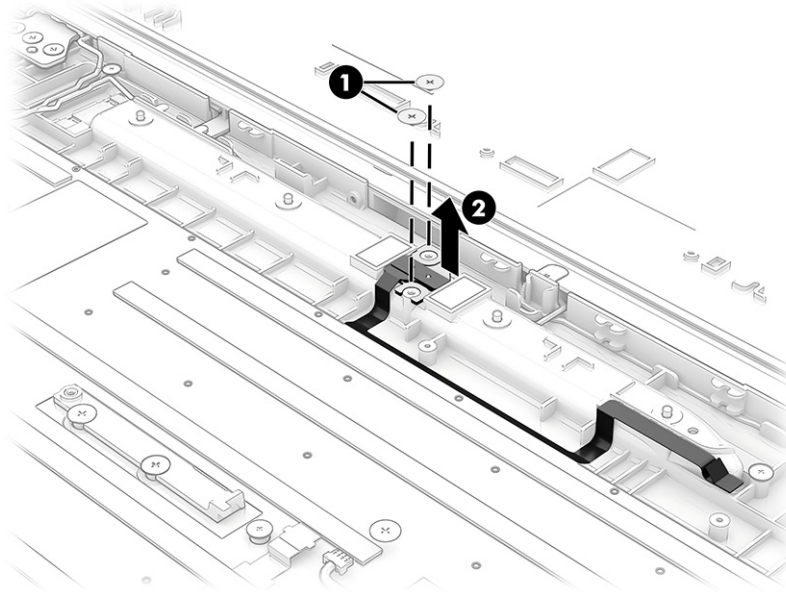

Reverse this procedure to install the POGO connector.

## Antenna bar

To remove and disassemble the antenna bar, use these procedures and illustrations.

**Table 6-10** Antenna bar description and part number

Description	Spare part number
Antenna bar (main)	M35272-001
Antenna bar (aux)	M35273-001

Before removing the antenna bar, follow these steps:

1. Prepare the computer for disassembly (see [Preparation for disassembly on page 28](#)).
2. Remove the bottom cover (see [Bottom cover on page 30](#)).
3. Disconnect the battery cable from the system board (see [Battery on page 31](#)).
4. Disconnect the display cable and the sensor cable (see [Display assembly on page 46](#)).
5. Remove the heat sink (see [Heat sink on page 36](#)).

Remove the antenna bar:

1. Disconnect the antenna cables from the WWAN module **(1)** and the integrated WLAN module **(2)**.
2. Remove the five reusable rubber screw covers from the antenna bar **(3)**.
3. Remove the five Phillips M2.0 × 3.0 screws **(4)** that secure the antenna bar to the computer.

 **NOTE:** Three of the screws are removed vertically. Two of the screws are removed horizontally.

4. Remove the antenna bar from the computer (5).

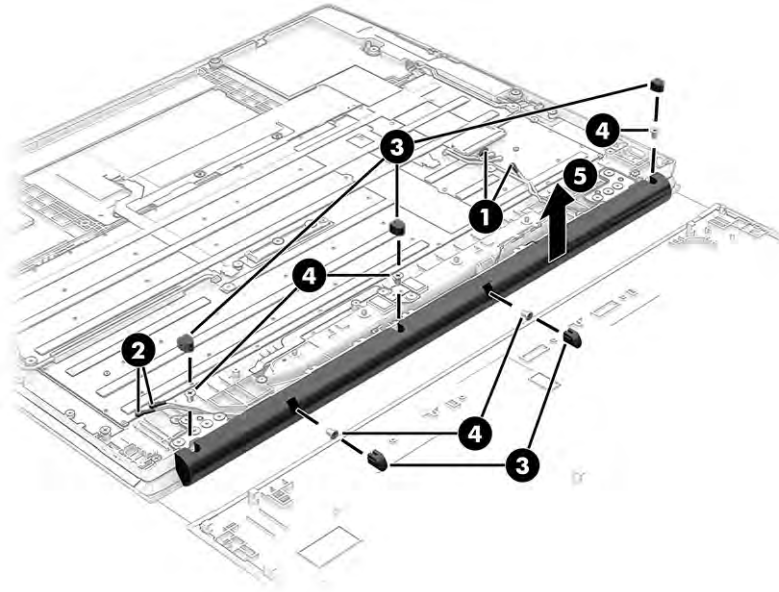

Reverse this procedure to install the antenna bar.

## Top cover with keyboard

The top cover with keyboard remains after removing all other spare parts from the computer. In this section, the first table provides the main spare part number for the top cover/keyboards. The second table provides the country codes.

**Table 6-11 Top cover with keyboard descriptions and part numbers**

Description	Spare part number
Top cover with keyboard, nonprivacy models	M35264-xx1
Top cover with keyboard, privacy models	M50327-xx1

**Table 6-12 Spare part country codes**

For use in country or region	Spare part number	For use in country or region	Spare part number	For use in country or region	Spare part number
Belgium	-A41	Hungary	-211	Saudi Arabia	-171
Brazil	-201	Iceland	-DD1	Slovenia	-BA1
Bulgaria	-261	India	-D61	South Korea	-AD1
Chile	-161	Israel	-BB1	Spain	-071
Czech Republic/Slovakia	-FL1	Italy	-061	Switzerland	-BG1
Denmark	-081	Japan	-291	Taiwan	-AB1
Denmark, Finland, and Norway	-DH1	The Netherlands	-B31	Thailand	-281
French Canada	-DB1	Northern Africa	-FP1	Turkey	-141

**Table 6-12 Spare part country codes (continued)**

For use in country or region	Spare part number	For use in country or region	Spare part number	For use in country or region	Spare part number
Finland/Sweden	-B71	Norway	-091	Turkey-F	-541
France	-051	Portugal	-131	Ukraine	-BD1
Germany	-041	Romania	-271	United Kingdom	-031
Greece	-151	Russia	-251	United States	-001

## Display assembly

To remove and disassemble the display assembly, use these procedures and illustrations.

 **NOTE:** Spare parts for displays are available only at the subcomponent level.

Before removing the display panel, follow these steps:

1. Prepare the computer for disassembly (see [Preparation for disassembly on page 28](#)).
2. Remove the bottom cover (see [Bottom cover on page 30](#)).
3. Disconnect the battery cable from the system board (see [Battery on page 31](#)).

Disassemble or remove the display assembly:

1. To remove the display panel:
  - a. Open the computer **(1)**.
  - b. Lift the bottom of the display and rotate it 180° so that the back of the display is facing you **(2)**.

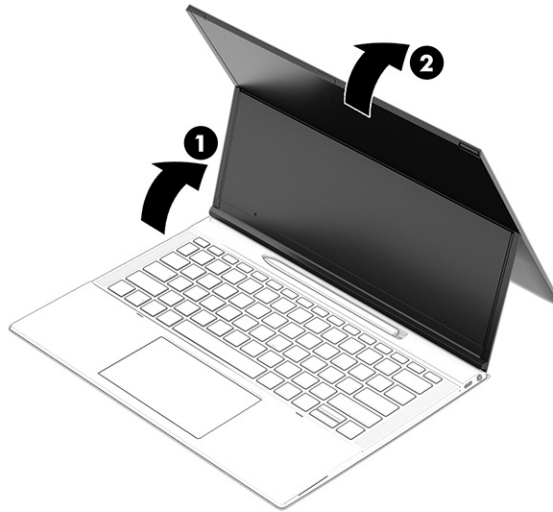

- c. Five strips of tape secure the panel to the display. Remove this tape in the following order:
- Long vertical strips along the left **(1)** and right **(2)** sides. If the tabs on the ends of the tape break before it is fully removed, you can use a suction cup and pick to lift the panel so you can gain access to the tape. HP recommends using a rounded hook tool (crochet tool) to remove the tape. Use tweezers to rotate and pull the tape out vertically (see step f).
  - One horizontal strip along the bottom **(3)**. You may need to use a suction cup to pull up the panel to access the bottom strip. Use tweezers to rotate and pull the tape out horizontally (see step f).
  - Two horizontal, short strips near the top left **(4)** and right **(5)** corners of the display.

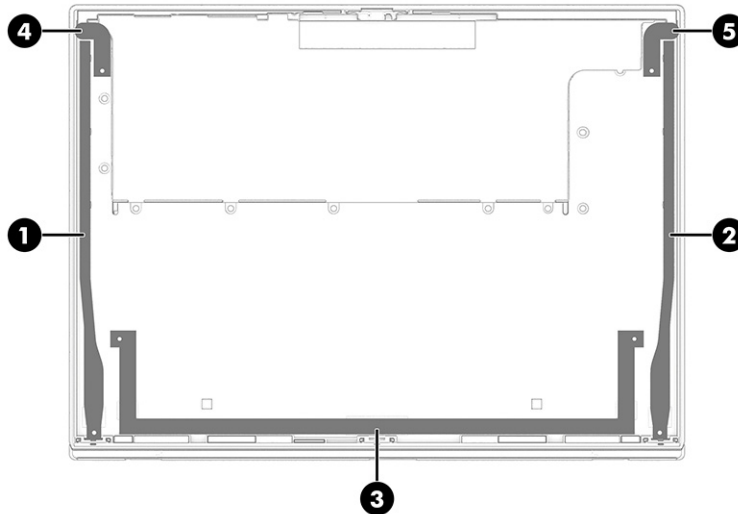

- d. Use tweezers to pull the cover in each corner off the bottom of the display panel **(1)**. The bottom will be closest to you in this position.
- e. Use tweezers to grasp and pull the end of the tape out from behind the panel. While turning the tweezers, wrap the tape around the tweezers **(2)** as you continue to pull the tape out from behind the display panel **(3)**. You must pull the tape multiple times before it is completely removed.



- f. Lift the panel off and place next to computer (4).

 **TIP:** If the tape breaks before you can completely remove it from behind the display panel, be sure to continue panel removal by using suction cups to remove the panel from the display rear cover.



- g. Disconnect the display cable from the transfer board (1). Be sure to lift the lever on the connector before disconnecting the cable.
- h. Disconnect the two cables from the ZIF connectors on the touch board (2).

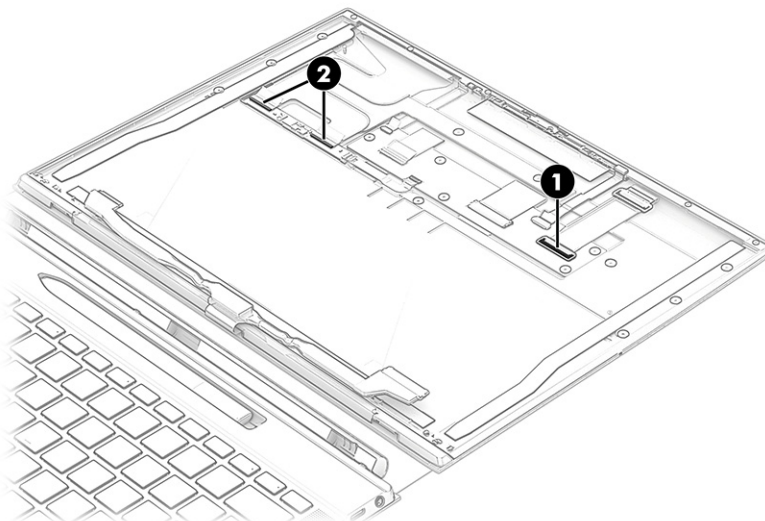





- i. When replacing the display panel, install adhesive strips in the following locations on the display rear cover.

 **NOTE:** Before installing new adhesive strips, be sure to fully remove all previous adhesive remnants so the surface is clean.

 **NOTE:** New adhesive strips are provided. Use the following information to install the new adhesive on the display rear cover:

- Follow the guides in the computer when installing in the display.
- The release paper is white and should be faced down.
- Be sure to place the right and left strips (#1 and #2) on the far edges of the display, and use the back edge of the guide to start the adhesive.
- For #4 and #5 adhesives, align the cutout in the adhesive to the edge (notch) of the camera.
- Press down on the strips multiple times to be sure there is good adhesion to the panel.
- After all panel cables are reconnected, starting with #4 and #5, remove the top side adhesive and press the panel onto these adhesives. Then remove the side and bottom adhesives (#1, #2, #3) and press the display onto these adhesives. Similarly, after you place the panel on the adhesive strips, press down on the panel several times in the locations of the strips to be sure there is good adhesion.
- Place the two rubber caps back onto the panel.

 **NOTE:** Privacy displays use unique adhesive strips on the right (**2**) and bottom (**3**) of the display. These strips are indicated by a raised P on strip as indicated in the locations in the following illustration.

 **NOTE:** After you install new adhesive strips, but before the panel is adhered to the strips, make sure that the display cable and touch board cable are reconnected and that the camera shutter is in place. You can turn on the computer to test the display before adhering the panel.

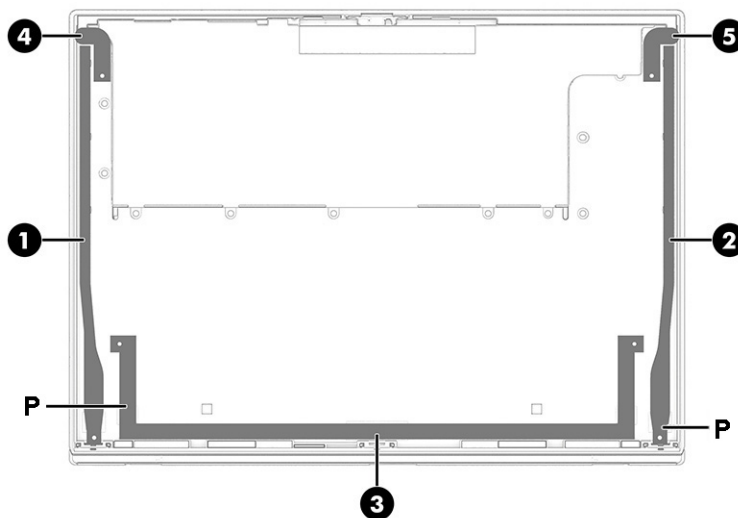

Display panels are available as spare part number M35262-001 for BrightView 400 nit panels and M35279-001 for BrightView, HP Sure View Reflect, 1000 nit panels.

2. To remove the transfer board from the display rear cover:

- a. Disconnect the six cables from the board **(1)**.
- b. Remove the five Phillips M1.4 × 1.2 screws from the board **(2)**.
- c. Remove the board from the computer **(3)**.

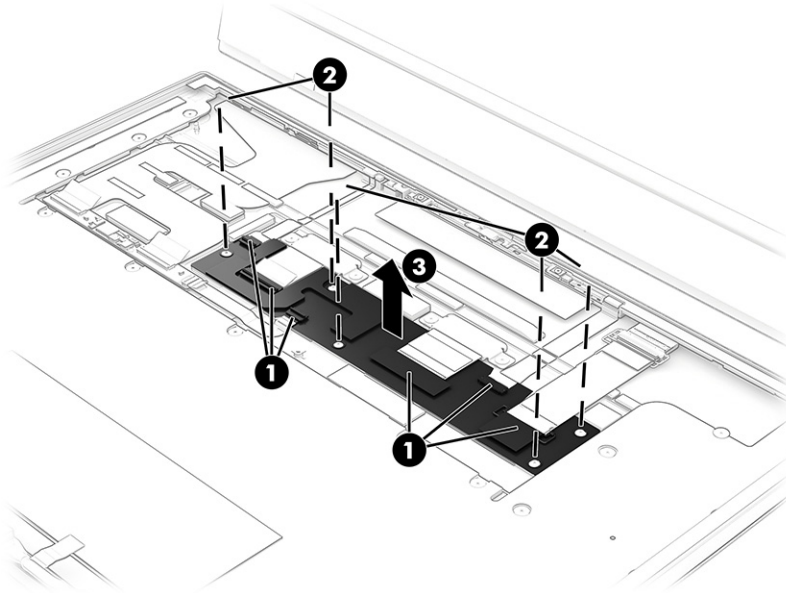

Transfer boards are available as spare part number M35276-001 for privacy models and M35277-001 for nonprivacy models.

3. To remove the touch board from the display rear cover:
  - a. Disconnect the cable from the ZIF connector on the end of the board **(1)**.
  - b. Use a tool to release the board from the inside of the display rear cover **(2)**. The board is secured with adhesive.

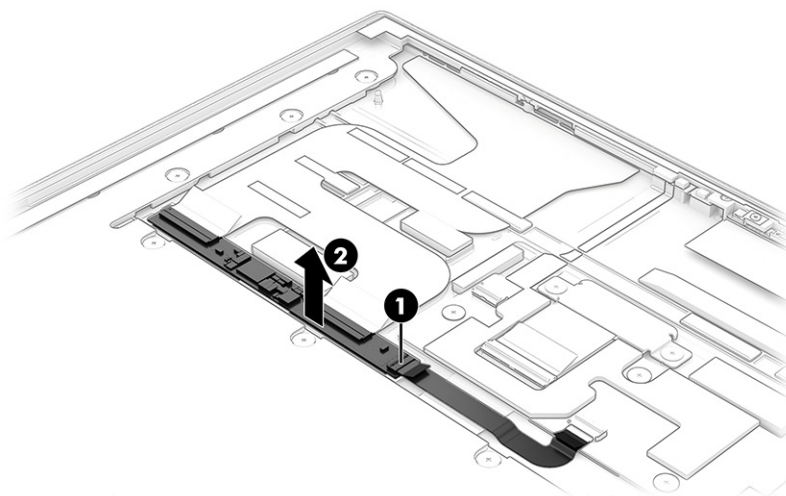

The touch control board is available as spare part number M35278-001.

4. To remove the camera module from the display rear cover:

- a. Disconnect the cable from the camera module **(1)**.
- b. Use a tool to release the module from the inside-top of the display rear cover **(2)**. The module is secured with adhesive.

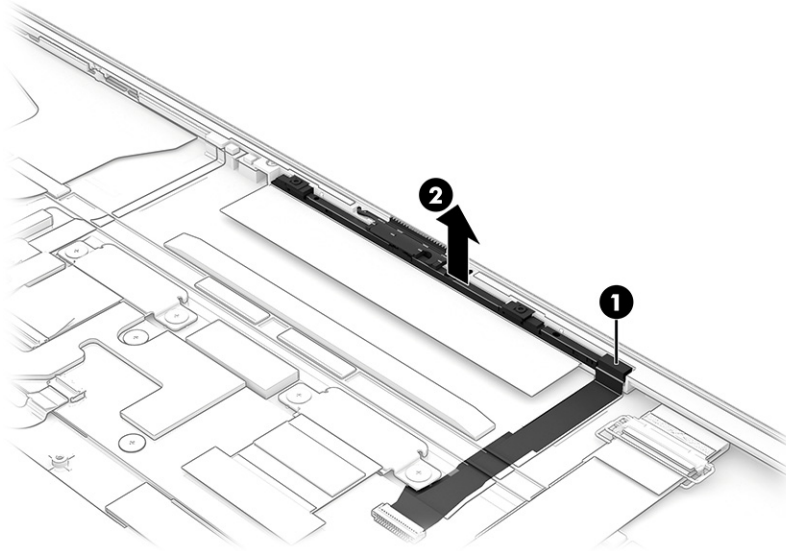

The camera module is available as spare part number M35270-001.

5. To remove the ambient light sensor board from the display rear cover:
  - a. Disconnect the cable from the ZIF connector on the transfer board **(1)**.
  - b. Use tweezers to release the board from the inside-top of the display rear cover **(2)**. The board is secured with adhesive.

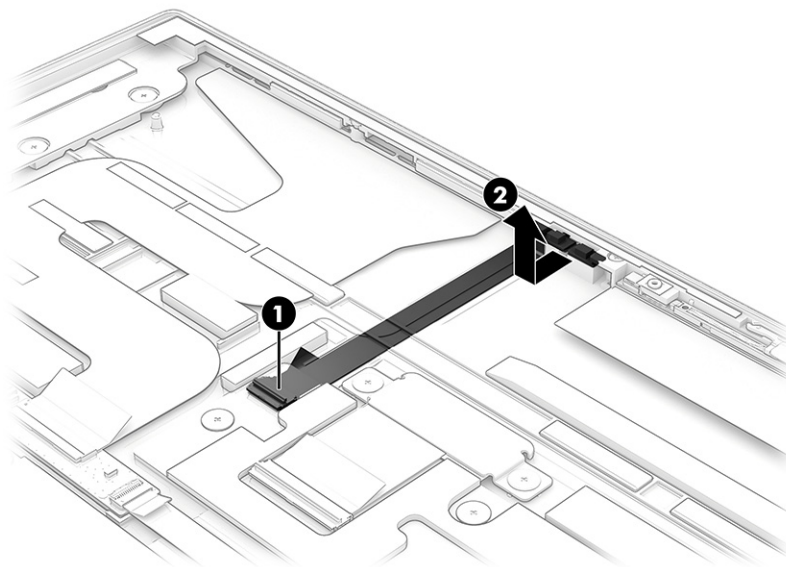

The ambient light sensor is available in the Display Cable Kit as spare part number M35258-001.

Reverse this procedure to reassemble and install the display assembly.

---

# 7 Backing up, restoring, and recovering

You can use Windows tools to back up your information, create a restore point, reset your computer, create recovery media, or restore your computer to its factory state. Performing these standard procedures can return your computer to a working state faster.

## Backing up information and creating recovery media

You can use Windows tools for backing up your information.

### Using Windows tools for backing up

HP recommends that you back up your information immediately after initial setup. You can do this task either using Windows Backup locally with an external USB drive or using online tools.

---

 **IMPORTANT:** Windows is the only option that allows you to back up your personal information. Schedule regular backups to avoid information loss.

 **NOTE:** If computer storage is 32 GB or less, Microsoft® System Restore is disabled by default.

---

## Restoring and recovering your system

You have several tools available to recover your system both within and outside of Windows if the desktop cannot load.

HP recommends that you attempt to restore your system using the [Restoring and recovery methods on page 52](#).

### Creating a system restore

System Restore is available in Windows. The System Restore software can automatically or manually create restore points, or snapshots, of the system files and settings on the computer at a particular point.

When you use System Restore, it returns your computer to its state at the time you made the restore point. Your personal files and documents should not be affected.

### Restoring and recovery methods

After you run the first method, test to see whether the issue still exists before you proceed to the next method, which might now be unnecessary.

1. Run a Microsoft System Restore.
2. Run Reset this PC.

For more information about the first two methods, see the Get Help app:

Select the **Start** button, select the **Get Help** app, and then enter the task you want to perform.

---

 **NOTE:** You must be connected to the internet to access the Get Help app.

---

---

# 8 Computer Setup (BIOS)

HP provides several tools to help set up and protect your computer.

## Using Computer Setup

Computer Setup, or Basic Input/Output System (BIOS), controls communication between all the input and output devices on the system (such as hard drives, display, keyboard, mouse, and printer). Computer Setup includes settings for types of devices installed, the startup sequence of the computer, and amount of system and extended memory.

---

 **NOTE:** Use extreme care when making changes in Computer Setup. Errors can prevent the computer from operating properly.

---

To start Computer Setup, turn on or restart the computer, and when the HP logo appears, press **f10** to enter Computer Setup.

## Navigating and selecting in Computer Setup

You can navigate and select in Computer Setup using one or more methods.

- To select a menu or a menu item, use the **tab** key and the keyboard arrow keys and then press **enter**, or use a pointing device to select the item.
- To scroll up and down, select the up arrow or the down arrow in the upper-right corner of the screen, or use the up arrow key or the down arrow key on the keyboard.
- To close open dialog boxes and return to the main Computer Setup screen, press **esc**, and then follow the on-screen instructions.

To exit Computer Setup, choose one of the following methods:

- To exit Computer Setup menus without saving your changes, select **Main**, select **Ignore Changes and Exit**, and then select **Yes**.

---

 **NOTE:** If you are using arrow keys to highlight your choice, you must then press **enter**.

---

- To save your changes and exit Computer Setup menus, select **Main**, select **Save Changes and Exit**, and then select **Yes**.

---

 **NOTE:** If you are using arrow keys to highlight your choice, you must then press **enter**.

---

Your changes go into effect when the computer restarts.

## Updating the BIOS

Updated versions of the BIOS will be available on through Windows Update. If Windows Update is enabled to automatically download and install BIOS updates on your computer, the BIOS will update the next time you restart your computer.

---

 **NOTE:** HP recommends that you configure Windows to update automatically to make sure that the computer has the latest software and security updates.

---

---

## 9 Using HP PC Hardware Diagnostics UEFI

HP PC Hardware Diagnostics UEFI (Unified Extensible Firmware Interface) allows you to run diagnostic tests to determine whether the computer hardware is functioning properly. The tool runs outside the operating system so that it can isolate hardware failures from issues that are caused by the operating system or other software components.



**NOTE:** For Windows 10 S computers, you must use a Windows computer and a USB flash drive to download and create the HP UEFI support environment because only .exe files are provided. For more information, see [Downloading HP PC Hardware Diagnostics UEFI to a USB flash drive on page 55](#).

If your PC does not start in Windows, you can use HP PC Hardware Diagnostics UEFI to diagnose hardware issues.

### Using an HP PC Hardware Diagnostics Windows hardware failure ID code

When HP PC Hardware Diagnostics Windows detects a failure that requires hardware replacement, a 24-digit failure ID code is generated for select component tests. For interactive tests, such as keyboard, mouse, or audio and video palette, you must perform troubleshooting steps before you can receive a failure ID.

▲ You have several options after you receive a failure ID:

- Click **Next** to open the Event Automation Service (EAS) page, where you can log the case.  
– or –
- Scan the QR code with your mobile device, which takes you to the EAS page, where you can log the case.  
– or –
- Click the box next to the 24-digit failure ID to copy your failure code and send it to support.

### Starting HP PC Hardware Diagnostics UEFI

To start HP PC Hardware Diagnostics UEFI, follow this procedure.

1. Turn on or restart the computer, and quickly press **esc**.
2. Press **f2**.

The BIOS searches three places for the diagnostic tools, in the following order:

**a.** Connected USB flash drive



**NOTE:** To download the HP PC Hardware Diagnostics UEFI tool to a USB flash drive, see [Downloading the latest HP PC Hardware Diagnostics UEFI version on page 55](#).

**b.** Hard drive

**c.** BIOS

3. When the diagnostic tool opens, select a language, select the type of diagnostic test you want to run, and then follow the on-screen instructions.

# Downloading HP PC Hardware Diagnostics UEFI to a USB flash drive

Downloading HP PC Hardware Diagnostics UEFI to a USB flash drive can be useful in some situations.

- HP PC Hardware Diagnostics UEFI is not included in the preinstallation image.
- HP PC Hardware Diagnostics UEFI is not included in the HP Tool partition.
- The hard drive is damaged.

---

 **NOTE:** The HP PC Hardware Diagnostics UEFI downloading instructions are provided in English only, and you must use a Windows computer to download and create the HP UEFI support environment because only .exe files are provided.

---

## Downloading the latest HP PC Hardware Diagnostics UEFI version

To download the latest HP PC Hardware Diagnostics UEFI version to a USB flash drive, follow this procedure.

1. Go to <http://www.hp.com/go/techcenter/pcdiags>. The HP PC Diagnostics home page is displayed.
2. Select **Download HP Diagnostics UEFI**, and then select **Run**.

## Downloading HP PC Hardware Diagnostics UEFI by product name or number

You can download HP PC Hardware Diagnostics UEFI by product name or number to a USB flash drive.

---

 **NOTE:** For some products, you might have to download the software to a USB flash drive by using the product name or number.

---

1. Go to <http://www.hp.com/support>.
2. Enter the product name or number, select your computer, and then select your operating system.
3. In the **Diagnostics** section, follow the on-screen instructions to select and download the specific UEFI Diagnostics version for your computer.

# 10 Specifications

This chapter provides specifications for your computer.

## Computer specifications

This section provides specifications for your computer. When traveling with your computer, the computer dimensions and weights, as well as input power ratings and operating specifications, provide helpful information.

**Table 10-1 Computer specifications**

	Metric	U.S.
<b>Dimensions</b>		
Width	<b>298.6 mm</b>	11.76 in
Depth	<b>229.6 mm</b>	9.04 in
Height	<b>16.1 mm</b>	0.64 in
<b>Weight</b>	<b>1.31 kg</b>	2.91 lbs
<b>Input power</b>		
Operating voltage and current	19.5 V dc @ 3.33 A – 65 W	
<b>Temperature</b>		
Operating	<b>5°C to 35°C</b>	41°F to 95°F
Nonoperating	<b>-20°C to 60°C</b>	-4°F to 140°F
<b>Relative humidity</b> (noncondensing)		
Operating	10% to 90%	
Nonoperating	5% to 95%	
<b>Maximum altitude</b> (unpressurized)		
Operating	<b>-15 m to 3,048 m</b>	-50 ft to 10,000 ft
Nonoperating	<b>-15 m to 12,192 m</b>	-50 ft to 40,000 ft
<b>NOTE:</b> Applicable product safety standards specify thermal limits for plastic surfaces. The device operates well within this range of temperatures.		

## Display specifications

This section provides specifications for your display.

**Table 10-2 Display specifications**

	Metric	U.S.
Active diagonal size	<b>34.3 cm</b>	13.5 in



**Table 10-2 Display specifications (continued)**

	Metric	U.S.
Resolution	1920 × 1280 (WUXGA+)	
Surface treatment	BrightView	
Brightness	400 nits (BrightView panels) 1000 nits (Antiglare panels)	
Viewing angle	UWVA	
Backlight	WLED	

## Solid-state drive specifications

This section provides specifications for your solid-state drives.

**Table 10-3 Solid-state drive specifications**

	128 GB*	256 GB*	512 GB*
<b>Dimensions</b>			
Height	1.0 mm	1.0 mm	1.0 mm
Length	50.8 mm	50.8 mm	50.8 mm
Width	28.9 mm	28.9 mm	28.9 mm
Weight	< 10 g	< 10 g	< 10 g
<b>Interface type</b>			
	PCIe	PCIe	PCIe
Ready time, maximum (to not busy)	1.0 ms	1.0 ms	< 1.0 ms
Access times, logical	1.0 ms	0.1 ms	0.1 ms
<b>Transfer rate</b>			
Sequential read	up to 2150 MB/s	up to 2150 MB/s	up to 2150 MB/s
Random read	Up to 300,000 IOPs	Up to 300,000 IOPs	Up to 300,000 IOPs
Sequential write	up to 1550 MB/s	up to 1550 MB/s	up to 1550 MB/s
Random write	Up to 100,000 IOPs	Up to 100,000 IOPs	Up to 100,000 IOPs
<b>Total logical sectors</b>	234,441,648	468,883,296	1,000,215,216
<b>Operating temperature</b>	<b>0°C to 70°C (32°F to 158°F)</b>		

\*1 GB = 1 billion bytes when referring to hard drive storage capacity. Actual accessible capacity is less. Actual drive specifications can differ slightly.

**NOTE:** Certain restrictions and exclusions apply. Contact support for details.

---

# 11 Statement of memory volatility

For general information regarding nonvolatile memory in HP business computers, and to restore nonvolatile memory that can contain personal data after the system has been turned off and the hard drive has been removed, use these instructions.

HP business computer products that use Intel®-based or AMD®-based system boards contain volatile DDR memory. The amount of nonvolatile memory present in the system depends upon the system configuration. Intel-based and AMD-based system boards contain nonvolatile memory subcomponents as originally shipped from HP, with the following assumptions:

- No subsequent modifications were made to the system.
- No applications, features, or functionality were added to or installed on the system.

Following system shutdown and removal of all power sources from an HP business computer system, personal data can remain on volatile system memory (DIMMs) for a finite period of time and also remains in nonvolatile memory. Use the following steps to remove personal data from the computer, including the nonvolatile memory found in Intel-based and AMD-based system boards.

---

 **NOTE:** If your tablet has a keyboard base, connect to the keyboard base before beginning steps in this chapter.

---

## Current BIOS steps

Use these instructions to restore nonvolatile memory.

1. Follow these steps to restore the nonvolatile memory that can contain personal data. Restoring or reprogramming nonvolatile memory that does not store personal data is neither necessary nor recommended.

- a. Turn on or restart the computer, and then quickly press `esc`.

---

 **NOTE:** If the system has a BIOS administrator password, enter the password at the prompt.

---

- b. Select **Main**, select **Apply Factory Defaults and Exit**, and then select **Yes** to load defaults. The computer restarts.

- c. During the restart, press `esc` while the "Press the ESC key for Startup Menu" message is displayed at the bottom of the screen.

---

 **NOTE:** If the system has a BIOS administrator password, enter the password at the prompt.

---

- d. Select the **Security** menu, select **Restore Security Settings to Factory Defaults**, and then select **Yes** to restore security level defaults. The computer reboots.

- e. During the reboot, press `esc` while the "Press the ESC key for Startup Menu" message is displayed at the bottom of the screen.

---

 **NOTE:** If the system has a BIOS administrator password, enter the password at the prompt.

---

- f. If an asset or ownership tag is set, select the **Security** menu and scroll down to the **Utilities** menu. Select **System IDs**, and then select **Asset Tracking Number**. Clear the tag, and then make the selection to return to the prior menu.

- g. If a DriveLock password is set, select the **Security** menu, and scroll down to **Hard Drive Utilities** under the **Utilities** menu. Select **Hard Drive Utilities**, select **DriveLock**, and then clear the check box for **DriveLock password on restart**. Select **OK** to proceed.
- h. Select the **Main** menu, and then select **Reset BIOS Security to factory default**. Select **Yes** at the warning message. The computer reboots.
- i. During the reboot, press **esc** while the "Press the ESC key for Startup Menu" message is displayed at the bottom of the screen.



---

**NOTE:** If the system has a BIOS administrator password, enter the password at the prompt.

---

- j. Select the **Main** menu, select **Apply Factory Defaults and Exit**, select **Yes** to save changes and exit, and then select **Shutdown**.
  - k. Reboot the system. If the system has a Trusted Platform Module (TPM), fingerprint reader, or both, one or two prompts will appear—one to clear the TPM and the other to Reset Fingerprint Sensor. Press or tap **f1** to accept or **f2** to reject.
  - l. Remove all power and system batteries for at least 24 hours.
2. Complete one of the following:
- Remove and retain the storage drive.  
– or –
  - Clear the drive contents by using a third-party utility designed to erase data from an SSD.  
– or –
  - Clear the contents of the drive by using the following BIOS Setup Secure Erase command option steps:

If you clear data using Secure Erase, you cannot recover it.

- a. Turn on or restart the computer, and then quickly press **esc**.
- b. Select the **Security** menu and scroll down to the **esc** menu.
- c. Select **Hard Drive Utilities**.
- d. Under **Utilities**, select **Secure Erase**, select the hard drive storing the data you want to clear, and then follow the on-screen instructions to continue.  
– or –

Clear the contents of the drive using the following Disk Sanitizer commands steps:

- i. Turn on or restart the computer, and then quickly press **esc**.
- ii. Select the **Security** menu and scroll down to the **Utilities** menu.
- iii. Select **Hard Drive Utilities**.
- iv. Under **Utilities**, select **Disk Sanitizer**, select the hard drive with the data that you want to clear, and then follow the on-screen instructions to continue.



---

**NOTE:** The amount of time it takes for Disk Sanitizer to run can take several hours. Plug the computer into an AC outlet before starting.

---

# Nonvolatile memory usage

Use this table to troubleshooting nonvolatile memory usage.

**Table 11-1 Troubleshooting steps for nonvolatile memory usage**

Nonvolatile memory type	Amount (Size)	Does this memory store customer data?	Does this memory retain data when power is removed?	What is the purpose of this memory?	How is data entered into this memory?	How is this memory write-protected?
HP Sure Start flash (select models only)	8 MB	No	Yes	Provides protected backup of critical System BIOS code, EC firmware, and critical computer configuration data for select platforms that support HP Sure Start.  For more information, see <a href="#">Using HP Sure Start (select products only) on page 63</a> .	Data cannot be written to this device via the host processor. The content is managed solely by the HP Sure Start Embedded Controller.	This memory is protected by the HP Sure Start Embedded Controller.
Real Time Clock (RTC) battery backed-up CMOS configuration memory	256 bytes	No	Yes	Stores system date and time and noncritical data.	RTC battery backed-up CMOS is programmed using Computer Setup (BIOS), or by changing the Windows date & time.	This memory is not write-protected.
Controller (NIC) EEPROM	64 KB (not customer accessible)	No	Yes	Stores NIC configuration and NIC firmware.	NIC EEPROM is programmed using a utility from the NIC vendor that can be run from DOS.	A utility must be used to write data to this memory and is available from the NIC vendor. Writing data to this ROM in an inappropriate manner will render the NIC non-functional.
DIMM Serial Presence Detect (SPD) configuration data	256 bytes per memory module, 128 bytes programmable (not customer accessible)	No	Yes	Stores memory module information.	DIMM SPD is programmed by the memory vendor.	Data cannot be written to this memory when the module is installed in a computer. The specific write-protection method varies by memory vendor.
System BIOS	9 MB	Yes	Yes	Stores system BIOS code and computer configuration data.	System BIOS code is programmed at the factory. Code is updated when the system BIOS is updated. Configuration data and settings are entered using the Computer Setup (BIOS) or a custom utility.	<b>NOTE:</b> Writing data to this ROM in an inappropriate manner can render the computer non-functional.  A utility must be used for writing data to this memory and is available

**Table 11-1 Troubleshooting steps for nonvolatile memory usage (continued)**

Nonvolatile memory type	Amount (Size)	Does this memory store customer data?	Does this memory retain data when power is removed?	What is the purpose of this memory?	How is data entered into this memory?	How is this memory write-protected?
Intel Management Engine Firmware (present only in select Elite or Z models. For more information, go to <a href="http://www.hp.com/support">http://www.hp.com/support</a> . Select <b>Identify your product for manuals and specific product information</b> , and then follow the on-screen instructions.)	1.5 MB or 7 MB	Yes	Yes	Stores Management Engine Code, Settings, Provisioning Data and iAMT third-party data store.	Management Engine Code is programmed at the factory. Code is updated via Intel secure firmware update utility. Unique Provisioning Data can be entered at the factory or by an administrator using the Management Engine (MEBx) setup utility. The third-party data store contents can be populated by a remote management console or local applications that have been registered by an administrator to have access to the space.	on the HP website; go to <a href="http://www.hp.com/support">http://www.hp.com/support</a> . Select <b>Find your product</b> , and then follow the on-screen instructions.
Bluetooth flash (select products only)	2 megabits	No	Yes	Stores Bluetooth configuration and firmware.	Bluetooth flash is programmed at the factory. Tools for writing data to this memory are not publicly available but can be obtained from the silicon vendor.	A utility must be used for writing data to this memory and is made available through newer versions of the driver whenever the flash requires an upgrade.
802.11 WLAN EEPROM	4 kilobits to 8 kilobits	No	Yes	Stores configuration and calibration data.	802.11 WLAN EEPROM is programmed at the factory. Tools for writing data to this memory are not made public.	A utility must be used for writing data to this memory and is typically not made available to the public unless a firmware upgrade is necessary to address a unique issue.
Camera (select products only)	64 kilobits	No	Yes	Stores camera configuration and firmware.	Camera memory is programmed using a utility from the device manufacturer that can be run from Windows.	A utility must be used for writing data to this memory and is typically not made available to the public unless a firmware upgrade is necessary to address a unique issue.
Fingerprint reader (select products only)	512 KB flash	Yes	Yes	Stores fingerprint templates.	Fingerprint reader memory is programmed by user enrollment in HP ProtectTools Security Manager.	Only a digitally signed application can make the call to write to the flash.

## Questions and answers

Use this section to answer your questions about nonvolatile memory.

### 1. How can the BIOS settings be restored (returned to factory settings)?

 **IMPORTANT:** The restore defaults feature does not securely erase any information on your hard drive. See question and answer 6 for steps to securely erase information.

The restore defaults feature does not reset the Custom Secure Boot keys. See question and answer 7 for information about resetting the keys.

- a. Turn on or restart the computer, and then quickly press `esc`.
- b. Select **Main**, and then select **Apply Factory Defaults and Exit**.
- c. Follow the on-screen instructions.
- d. Select **Main**, select **Save Changes and Exit**, and then follow the on-screen instructions.

### 2. What is a UEFI BIOS, and how is it different from a legacy BIOS?

The Unified Extensible Firmware Interface (UEFI) BIOS is an industry-standard software interface between the platform firmware and an operating system (OS). It replaces the older BIOS architecture but supports much of the legacy BIOS functionality.

Like the legacy BIOS, the UEFI BIOS provides an interface to display the system information and configuration settings and to change the configuration of your computer before an OS is loaded. BIOS provides a secure runtime environment that supports a Graphic User Interface (GUI). In this environment, you can use either a pointing device (touch screen, touchpad, pointing stick, or USB mouse) or the keyboard to navigate and make menu and configuration selections. The UEFI BIOS also contains basic system diagnostics.

The UEFI BIOS provides functionality beyond that of the legacy BIOS. In addition, the UEFI BIOS works to initialize the computer's hardware before loading and executing the OS; the runtime environment allows the loading and execution of software programs from storage devices to provide more functionality, such as advanced hardware diagnostics (with the ability to display more detailed system information) and advanced firmware management and recovery software.

HP has provided options in Computer Setup (BIOS) to allow you to run in legacy BIOS, if required by the operating system. Examples of this requirement would be if you upgrade or downgrade the OS.

### 3. Where is the UEFI BIOS located?

The UEFI BIOS is located on a flash memory chip. You must use a utility to write to the chip.

### 4. What kind of configuration data is stored on the DIMM Serial Presence Detect (SPD) memory module? How would this data be written?

The DIMM SPD memory contains information about the memory module, such as size, serial number, data width, speed and timing, voltage, and thermal information. This information is written by the module manufacturer and stored on an EEPROM. You cannot write to this EEPROM when the memory module is installed in a computer. Third-party tools do exist that can write to the EEPROM when the memory module is not installed in a computer. Various third-party tools are available to read SPD memory.

### 5. What is meant by “Restore the nonvolatile memory found in Intel-based system boards”?

This message relates to clearing the Real Time Clock (RTC) CMOS memory that contains computer configuration data.

### 6. How can the BIOS security be reset to factory defaults and erase the data?

---

 **IMPORTANT:** Resetting results in the loss of information.

These steps do not reset Custom Secure Boot Keys. See question and answer 7 for information about resetting the keys.

---

- a. Turn on or restart the computer, and then quickly press **esc**.
- b. Select **Main**, and then select **Reset Security to Factory Defaults**.
- c. Follow the on-screen instructions.
- d. Select **Main**, select **Save Changes and Exit**, and then follow the on-screen instructions.

#### 7. How can the Custom Secure Boot Keys be reset?

Secure Boot is a feature to ensure that only authenticated code can start on a platform. If you enabled Secure Boot and created Custom Secure Boot Keys, disabling Secure Boot does not clear the keys. You must also select to clear the Custom Secure Boot Keys. Use the same Secure Boot access procedure that you used to create the Custom Secure Boot Keys, but select to clear or delete all Secure Boot Keys.

- a. Turn on or restart the computer, and then quickly press **esc**.
- b. Select the **Security** menu, select **Secure Boot Configuration**, and then follow the on-screen instructions.
- c. At the **Secure Boot Configuration** window, select **Secure Boot**, select **Clear Secure Boot Keys**, and then follow the on-screen instructions to continue.

## Using HP Sure Start (select products only)

Select computer models are configured with HP Sure Start, a technology that continuously monitors your computer's BIOS for attacks or corruption.

If the BIOS becomes corrupted or is attacked, HP Sure Start restores the BIOS to its previously safe state, without user intervention. Those select computer models ship with HP Sure Start configured and enabled. HP Sure Start is configured and already enabled so that most users can use the HP Sure Start default configuration. Advanced users can customize the default configuration.

To access the latest documentation on HP Sure Start, go to <http://www.hp.com/support>.

---

## 12 Recycling

When a nonrechargeable or rechargeable battery has reached the end of its useful life, do not dispose of the battery in general household waste. Follow the local laws and regulations in your area for battery disposal.

HP encourages customers to recycle used electronic hardware, HP original print cartridges, and rechargeable batteries. For more information about recycling programs, see the HP website at <http://www.hp.com/recycle>.



# 13 Power cord set requirements

This chapter provides power cord requirements for countries and regions.

The wide-range input feature of the computer permits it to operate from any line voltage from 100 V ac to 120 V ac, or from 220 V ac to 240 V ac.

The three-conductor power cord set included with the computer meets the requirements for use in the country or region where the equipment is purchased.

Power cord sets for use in other countries or regions must meet the requirements of the country and region where the computer is used.

## Requirements for all countries

These power cord requirements are applicable to all countries and regions.

- The length of the power cord set must be at least **1.0 m** (3.3 ft) and no more than **2.0 m** (6.5 ft).
- All power cord sets must be approved by an acceptable accredited agency responsible for evaluation in the country or region where the power cord set will be used.
- The power cord sets must have a minimum current capacity of 10 A and a nominal voltage rating of 125 V ac or 250 V ac, as required by the power system of each country or region.
- The appliance coupler must meet the mechanical configuration of an EN 60 320/IEC 320 Standard Sheet C13 connector for mating with the appliance inlet on the back of the computer.

## Requirements for specific countries and regions

To determine power cord requirements for specific countries and regions, use this table.

**Table 13-1 Power cord requirements for specific countries and regions**

Country/region	Accredited agency	Applicable note number
Argentina	IRAM	1
Australia	SAA	1
Austria	OVE	1
Belgium	CEBEC	1
Brazil	ABNT	1
Canada	CSA	2
Chile	IMQ	1
Denmark	DEMKO	1
Finland	FIMKO	1
France	UTE	1
Germany	VDE	1

**Table 13-1 Power cord requirements for specific countries and regions (continued)**

Country/region	Accredited agency	Applicable note number
India	BIS	1
Israel	SII	1
Italy	IMQ	1
Japan	JIS	3
Netherlands	KEMA	1
New Zealand	SANZ	1
Norway	NEMKO	1
People's Republic of China	CCC	4
Saudi Arabia	SASO	7
Singapore	PSB	1
South Africa	SABS	1
South Korea	KTL	5
Sweden	SEMKO	1
Switzerland	SEV	1
Taiwan	BSMI	6
Thailand	TISI	1
United Kingdom	ASTA	1
United States	UL	2

1. The flexible cord must be Type H05VV-F, three-conductor, 0.75 mm<sup>2</sup> conductor size. Power cord set fittings (appliance coupler and wall plug) must bear the certification mark of the agency responsible for evaluation in the country or region where it will be used.
2. The flexible cord must be Type SVT/SJT or equivalent, No. 18 AWG, three-conductor. The wall plug must be a two-pole grounding type with a NEMA 5-15P (15 A, 125 V ac) or NEMA 6-15P (15 A, 250 V ac) configuration. CSA or C-UL mark. UL file number must be on each element.
3. The appliance coupler, flexible cord, and wall plug must bear a T mark and registration number in accordance with the Japanese Dentori Law. The flexible cord must be Type VCTF, three-conductor, 0.75 mm<sup>2</sup> or 1.25 mm<sup>2</sup> conductor size. The wall plug must be a two-pole grounding type with a Japanese Industrial Standard C8303 (7 A, 125 V ac) configuration.
4. The flexible cord must be Type RVV, three-conductor, 0.75 mm<sup>2</sup> conductor size. Power cord set fittings (appliance coupler and wall plug) must bear the CCC certification mark.
5. The flexible cord must be Type H05VV-F three-conductor, 0.75 mm<sup>2</sup> conductor size. KTL logo and individual approval number must be on each element. Approval number and logo must be printed on a flag label.
6. The flexible cord must be Type HVCTF three-conductor, 1.25 mm<sup>2</sup> conductor size. Power cord set fittings (appliance coupler, cable, and wall plug) must bear the BSMI certification mark.
7. For 127 V ac, the flexible cord must be Type SVT or SJT 3-conductor, 18 AWG, with plug NEMA 5-15P (15 A, 125 V ac), with UL and CSA or C-UL marks. For 240 V ac, the flexible cord must be Type H05VV-F three-conductor, 0.75 mm<sup>2</sup> or 1.00 mm<sup>2</sup> conductor size, with plug BS 1363/A with BSI or ASTA marks.

# Index

## A

AC adapters, spare part numbers 18  
Action keys, identifying 12  
audio-out (headphone)/audio-in  
(microphone) combo jack,  
identifying 4

## B

backup, creating 52  
backups 52  
battery light 4, 5  
BIOS  
    updating 53  
Bluetooth label 12  
bottom 12  
bottom cover  
    removal 30  
    spare part number 30  
buttons  
    digital pen 11  
    digital pen, pairing 11  
    left touchpad 8  
    power 10  
    right touchpad 8

## C

camera 6  
    identifying 6  
camera light, identifying 6  
camera privacy cover, identifying 6  
caps lock light, identifying 9  
caring for your computer 24  
cautions  
    electrostatic discharge 20, 21  
cleaning your computer 24  
    caring for wood veneer 26  
    disinfecting 25  
    HP Easy Clean 24  
    removing dirt and debris 24  
components  
    display 5  
    keyboard area 7  
    left side 5  
    right side 4  
computer major components 16

## Computer Setup

    navigating and selecting 53  
    starting 53  
computer specifications 56

## D

digital pen  
    pairing button 11  
digital pen buttons, identifying 11  
digital pen light, identifying 11  
digital pen pairing button,  
    identifying 11  
display  
    specifications 56  
display components 5

## E

electrostatic discharge (ESD) 20, 21  
    preventing damage 20, 21, 22  
esc key, identifying 12

## F

fn key, identifying 12  
fn lock light, identifying 9

## G

grounding methods 20, 21, 22  
guidelines  
    packaging 20, 26  
    transporting 20, 26  
    workstation 20

## H

hard drive  
    specifications 56  
heat sink  
    removal 36  
    spare part number 36  
HP PC Hardware Diagnostics UEFI  
    downloading 55  
    starting 54  
    using 54  
HP PC Hardware Diagnostics Windows  
    failure ID code 54  
HP Sure Start 58, 63

## I

illustrated parts catalog 16  
internal microphones, identifying 6

## J

jacks  
    audio-out (headphone)/audio-in  
    (microphone) combo 4

## K

keyboard  
    product description 2  
keys  
    esc 12  
    fn 12  
    Windows 12  
keys,  
    action 12

## L

labels  
    Bluetooth 12  
    regulatory 12  
    serial number 12  
    service 12  
    wireless certification 12  
    WLAN 12

left side components 5

## lights

AC adapter and battery 4, 5  
battery 4, 5  
camera 6  
caps lock 9  
digital pen 11  
fn lock 9  
power 9  
privacy key 9

## M

memory  
    nonvolatile 58  
    volatile 58

## N

nonvolatile memory 58

- P**
- packaging guidelines 20, 26
  - pen
    - removal 28
    - spare part number 28
  - pen pocket, identifying 11
  - Plastics Kit, spare part number 18
  - POGO connector
    - removal 43
    - spare part number 43
  - pointing device, product description 2
  - ports
    - product description 2
    - USB Type-C 4, 5
  - power button, identifying 10
  - power cord
    - requirements for all countries 65
    - requirements for specific countries and regions 65
    - set requirements 65
  - power cords, spare part numbers 18
  - power lights 9
  - privacy key light 9
  - product description
    - keyboard 2
    - pointing device 2
    - ports 2
    - sensors 2
  - product name and number, computer 12
- R**
- recovery 52
  - recovery media 52
    - creating using Windows tools 52
  - regulatory information
    - regulatory label 12
    - wireless certification labels 12
  - removal and replacement
    - procedures 28, 30
    - solid-state drive 37
  - removing personal data from volatile system memory 58
  - restoring 52
  - right side components 4
  - Rubber Kit, spare part number 18
- S**
- Screw Kit, spare part number 18
  - sensors
    - product description 2
  - serial number, computer 12
  - service labels, locating 12
  - setup utility
    - navigating and selecting 53
  - SIM card tray, identifying 10
  - SIM card, correct size 14
  - SIM card, inserting 14
  - solid-state drive
    - removal and replacement 37
    - specifications 57
  - spare part country codes 45
  - speaker, identifying 5
  - speakers
    - removal 33
    - spare part numbers 33
  - speakers, identifying 10
  - special keys, using 11
  - specifications
    - computer 56
    - display 56
    - hard drive 56
    - solid-state drive 57
  - static electricity 20, 21
  - support information 26
  - system board
    - removal 41
    - spare part numbers 41
  - system memory, removing personal data from volatile 58
  - system restore 52
  - system restore point, creating 52
- T**
- top cover with keyboard
    - spare part numbers 45
  - touchpad
    - removal 34
    - settings 7
    - spare part number 34
  - touchpad buttons
    - identifying 8
  - touchpad zone, identifying 8
  - transporting guidelines 20, 26
  - traveling with the computer 12
- U**
- USB Type-C port, identifying 4, 5
- W**
- Windows
    - backup 52
    - recovery media 52
    - system restore point 52
  - Windows key, identifying 12
  - Windows tools, using 52
  - wireless antennas and cables
    - removal 35
    - spare part number 35
  - wireless antennas, identifying 6
  - wireless certification label 12
  - WLAN antennas, identifying 6
  - WLAN device 12
  - WLAN label 12
  - workstation guidelines 20
  - WWAN antennas, identifying 6
  - WWAN module
    - removal 39
    - spare part numbers 39