



Maintenance and Service Guide

OMEN X 25f model

SUMMARY

This guide provides information about spare parts, removal and replacement of parts, diagnostic tests, problem troubleshooting, and more.

© Copyright 2021 HP Development Company, L.P.

AMD is a trademark of Advanced Micro Devices, Inc. Bluetooth is a trademark owned by its proprietor and used by HP Inc. under license. NVIDIA is a trademark and/or registered trademark of NVIDIA Corporation in the U.S. and other countries. USB Type-C and USB-C are registered trademarks of USB Implementers Forum. DisplayPort and the DisplayPort logo are trademarks owned by the Video Electronics Standards Association (VESA) in the United States and other countries.

The information contained herein is subject to change without notice. The only warranties for HP products and services are set forth in the express warranty statements accompanying such products and services. Nothing herein should be construed as constituting an additional warranty. HP shall not be liable for technical or editorial errors or omissions contained herein.

First Edition: March 2021

Document Part Number:

L40999- Omen X 25f-MSG-V1

Assembly part number: L40999-001

Product notice

Only trained service personnel familiar with this product should service it. Before performing any maintenance or service, be sure to read "Important Safety Information".

Table of Contents

Getting started	2
Important safety information	2
RoHS (2002/95/EC) requirements	3
General descriptions.....	3
Before return to receiver:	3
Monitor features	4
Features.....	4
Front View.....	5
Rear components	6
Locating the serial number and product number	7
Illustrated parts catalog	8
How to order parts.....	9
Removal and replacement procedures	10
Preparation for disassembly	10
Main board- Connector repair	14
Audio Connector repair- J11.....	16
USB A 3.0 Connector repair- J5, J6	16
USB B 3.0 Connector repair- J4.....	17
HDMI Connector repair- J8, J9.....	18
DP Connector repair- J7.....	19
Stick Gasket on the Shielding	20
Function Test:	21
Support and Troubleshooting	22
Index	23

Getting started

Read this chapter to learn about safety information and where to find additional HP resources.

Important safety information

It is important to note that this manual contains various CAUTIONS and NOTICES which should be carefully read in order to minimize the risk of personal injury to service personnel. Proper service and repair are important to the safe, reliable operation equipment.

The possibility exists that improper service methods may damage the equipment. It is also important to understand that these CAUTIONS and NOTICES ARE NOT EXHAUSTIVE.

The service procedures recommended and described in this service manual with effective methods of performing service operations. It is recommended that service engineers should have repairing knowledge, experience as well as appropriate product training per new model before performing the service procedures.

- Be sure your working environment is dry and clean and meets all government safety requirements.
- Be sure that other persons are safe while you are servicing the product.
- Do not perform any action that can cause a hazard to the customer or make the product unsafe.
- Use proper safety devices to ensure your personal safety.
- Always use approved tools and test equipment for servicing.
- Never assume the product's power is disconnected from the main power supply. Check that it is disconnected before opening the product's cabinet.
- Modules containing electrical components are sensitive to electrostatic discharge (ESD). Follow ESD safety procedures while handling these parts.
- Some products contain more than one battery. Do not disassemble or expose a battery to high temperatures, such as throwing into fire, or the battery may explode.
- Refer to government requirements for battery recycling or disposal.

This information provides general service information for the monitor. Adherence to the procedures and precautions is essential for proper service.

IMPORTANT:

Only trained service personnel who are familiar with this HP Product shall perform service or maintenance to it. Before performing any maintenance or service, the engineer **MUST** read the "Safety Note".

You must disconnect the power cord from the power source before opening the monitor to prevent component damage.

RoHS (2002/95/EC) requirements

Applied to all countries that require RoHS.

The RoHS (Restriction of Hazardous Substance in Electrical and Electronic Equipment Directive) is a legal requirement by the EU (European Union) for the global electronics industry sold in the EU and other countries. Any electrical and electronics products launched in the market after June 2006 should meet this RoHS requirement. Products launched in the market before June 2006 are not required to be compliant with RoHS parts. If the original parts are not RoHS compliant, the replacement parts can be non-ROHS compliant. If the original parts are RoHS compliant, the replacement parts **MUST** be RoHS compliant.

If product service or maintenance requires replacing parts, confirm the RoHS requirement before replacement.

General descriptions

This manual contains general information. There are two levels of service:

Level 1: Cosmetic/appearance/alignment service

Level 2: Circuit board or standard parts replacement

Before return to receiver:

- Please always perform an AC leakage current check on the exposed metallic parts to be sure the set is safe to operate without damage of electrical shock.
- Do not use a line Isolation Transformer during this check.
- In case any measurement is out of the limits specified, there is possibility of shock hazard and the set must be checked and repaired before it is returned to the customer.

Monitor features

This chapter provides an overview of the monitor's features.

Features

Depending on the model, your monitor might include the following features:

- 62.23 cm (24.5 in) diagonal viewable area with 1920 × 1080 FHD resolution
- Tilt and height-adjustment capabilities
- Two High-Definition Multimedia Interface (HDMI) video inputs
- DisplayPort video input
- High-bandwidth Digital Content Protection (HDCP) used on all inputs
- USB hub with one upstream port and two downstream ports
- Audio-out (headset) jack
- DisplayPort and USB Type-B-to-USB Type-A cables included
- Plug and Play capability if supported by your operating system
- On-screen display (OSD) adjustments in ten languages for easy setup and screen optimization
- Frames-per-second indicator displayed on the monitor screen, adjustable using the OSD menu
- Message timer displayed on the monitor screen, adjustable using the OSD menu
- Gaming crosshair displayed on the monitor screen, adjustable using the OSD menu
- Security cable slot on the rear of the monitor for an optional security cable
- User-configurable ambient lighting with full-range LEDs
- Convenient headphone storage hook on monitor stand
- VESA mounting capability for attaching the display to a wall mount device or swing arm

NOTE: For safety and regulatory information, refer to the Product Notices provided in your documentation kit. To locate updates to the user guide for your product, go to <http://www.hp.com/support> to download the latest versions of HP programs and drivers

Front View



Rear components

To identify the components on the rear of the monitor, use this illustration and table.



Table 1-1: Rear components and their descriptions

Component	Function
(1) Power button	Turns the monitor on or off.
(2) OSD joystick	Opens the OSD menu, selects an item from the menu, or closes the OSD menu.
(3) Security cable slot	Connects an optional security cable to the monitor.
(4) Audio-out jack	Connects optional powered stereo speakers, headphones, earbuds, a headset, or a television audio cable. WARNING! To reduce the risk of personal injury, adjust the source device volume before using headphones, earbuds, or a headset. For additional safety information, see the <i>Product Notices</i> provided in your documentation kit.
(5) USB ports (downstream) (2)	Connect USB cables to a peripheral device, such as a keyboard, mouse, or USB hard drive.
(6) USB Type-B port (upstream)	Connects the USB hub cable to a source device such as a computer or game console.
(7) Power connector	Connects an AC adapter.
(8) HDMI 1 port	Connects an HDMI cable to a source device such as a computer or game console.
(9) HDMI 2 port	Connects an HDMI cable to a source device such as a computer or game console.
(10) DisplayPort connector	Connects a DisplayPort cable to a source device such as a computer or game console.

Locating the serial number and product number

The serial number and product number are located on a label on the bottom edge of the monitor head. You may need these numbers when contacting HP about the monitor model



Illustrated parts catalog

To identify the monitor major components, use this illustration and table.

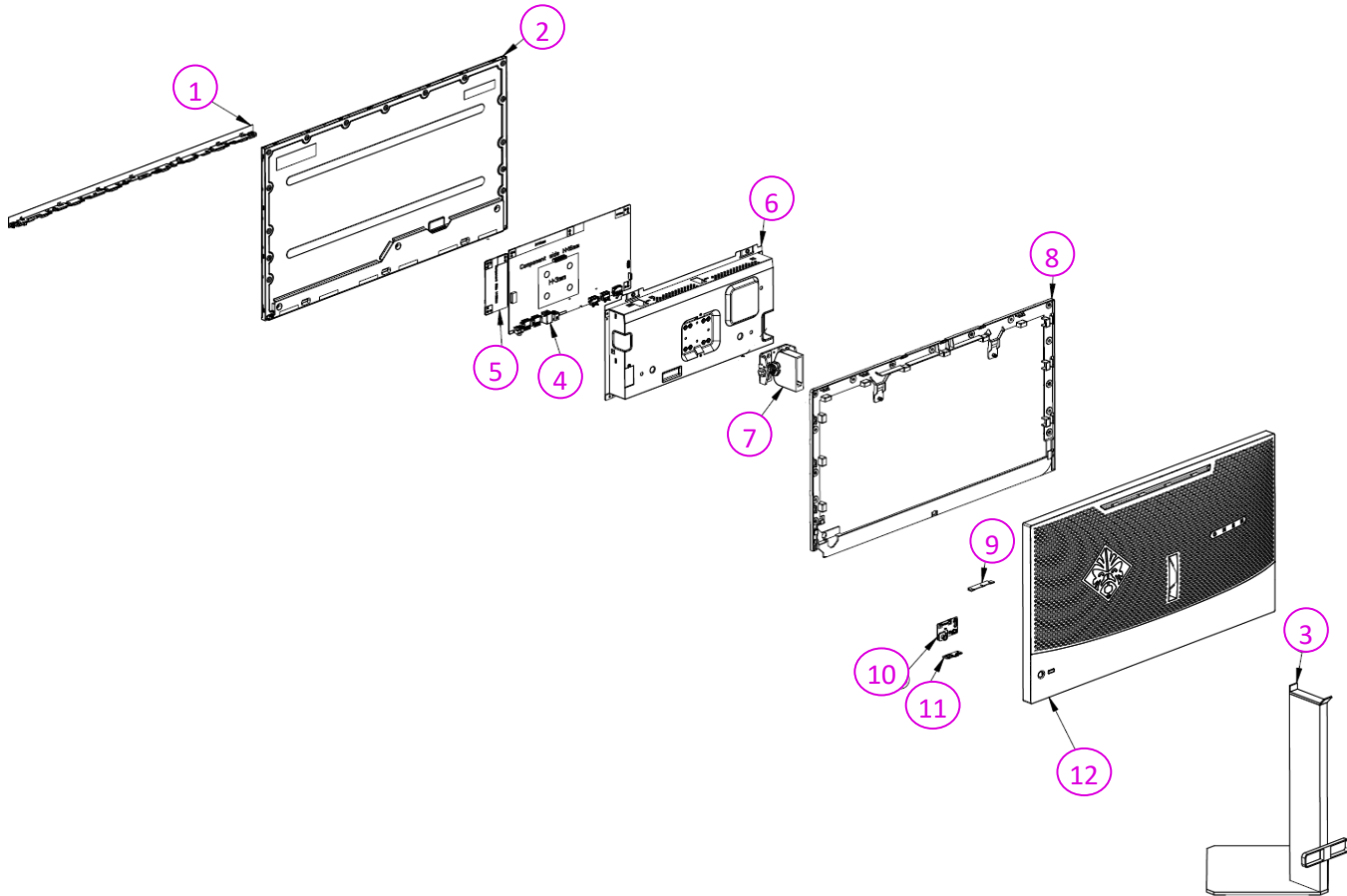

Table 2-1: Monitor major components and their descriptions

Item	Description	Qty
1	ASSY CHIN OMEN X 25F	1
2	PANEL	1
3	ASSY STAND	1
4	PCBA IF BD	1
5	PCBA LED DRV BD	1
6	ASSY SHD	1
7	ASSY HINGE	1
8	MID FRAME	1
9	PCBA LED BD	1
10	PCBA CTRL BD	1
11	PCBA CTRL LENS BD	1
12	ASSY RC	1

How to order parts

Capacitors and connectors available for purchase from EU distributor

- Farnell: [Farnell UK - Electronic Components Distributor](#)
- RS Component: [Capacitors | RS Components \(rs-online.com\)](#)

Connectors by Distributor:

Component Description	Location Identifier	Component Distributor	Part number of Manufacturer/ Distributor
DisplayPort (DP)	J7	Farnell	47272-0024
HDMI	J8, J9	Farnell, RS	Molex 2086581001
Audio	J11	Farnell	STX-3120-5B
USB A 3.0	J5, J6	RS	Molex 48405-0003
USB B 3.0	J4	Farnell	WURTH ELEKTRONIK 692221030100

Gasket by Distributor:

Component Description	Location Identifier	Component Distributor	Part number of Manufacturer/ Distributor
Gasket for DP and HDMI	SHD	Farnell	3020812
Specification: Gasket, EMI Shielding, 8 mm Width, 12 mm Height, 1 m Length, 80 dB			

To replace DP or HDMI, must need a gasket stick on shielding.

Cables can be purchased from the HP Part Store

<https://partsurfer.hp.com/Search.aspx>

Removal and replacement procedures

Adherence to these procedures and precautions is essential for proper service.

Preparation for disassembly



Use this information to properly prepare to disassemble and reassemble the monitor.

Use this information to properly prepare to disassemble and reassemble the monitor.

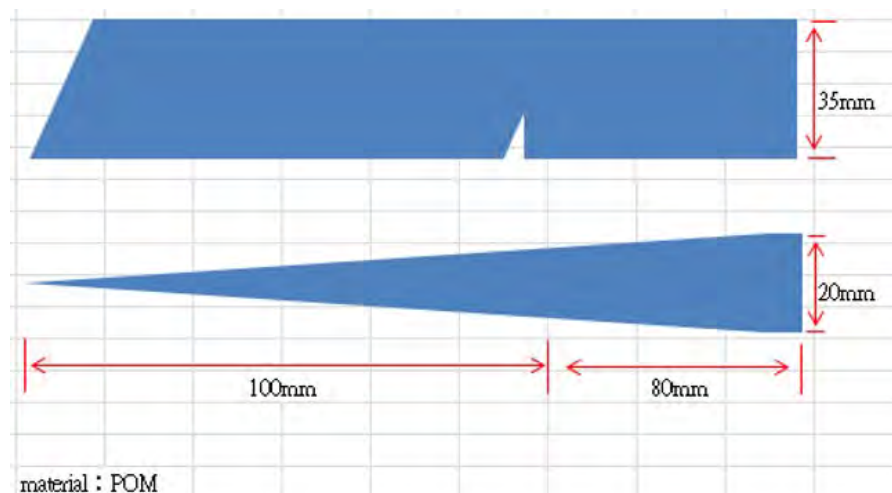
- 1) Clean the room for disassembly.
- 2) Identify the disassembly area.
- 3) Check the position that the monitors are to be placed along with the number of monitors. Prepare the area for material flow according to the disassembly layout.
- 4) Be sure to have the following equipment and materials:
 - Press fixture
 - Working table
 - Screwdriver
 - Knife
 - Gloves
 - Cleaning cloth
 - ESD protection
 - Scraper bar in the following dimensions:

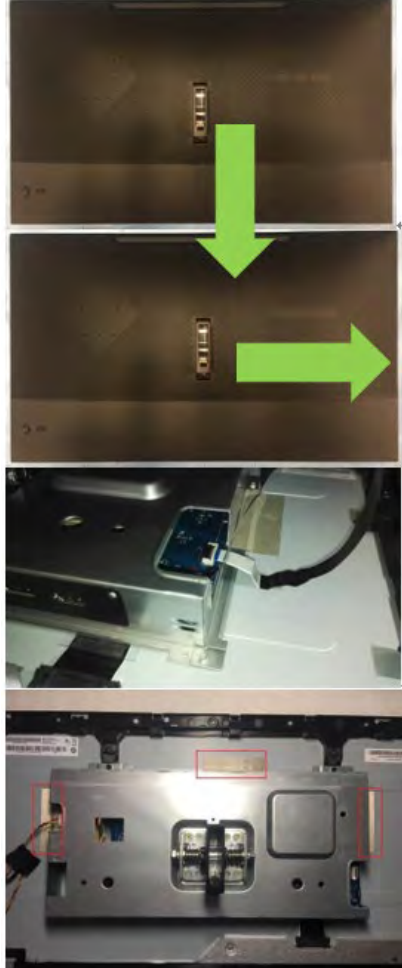

Disassembly procedure

Item	Picture	Operation	Tool	Notes
1		<ol style="list-style-type: none"> 1. Unlock 2 pcs screws 2. Remove Assy Stand from monitor 	Screw-driver	6.5±1.0kg
2		<ol style="list-style-type: none"> 1. Disassemble ASSY CHIN from panel 2. Unlock 2 pcs screws 	Screw-driver	4.5±0.5Kg
3		<p>Disassemble the RC from the monitor, notice the disassembly order:</p> <ol style="list-style-type: none"> 1. Disassemble the Bottom part 2. Disassemble the Right part 3. Remove LED cable and CTRL cable from IF BD 3. Remove RC from middle frame. 		

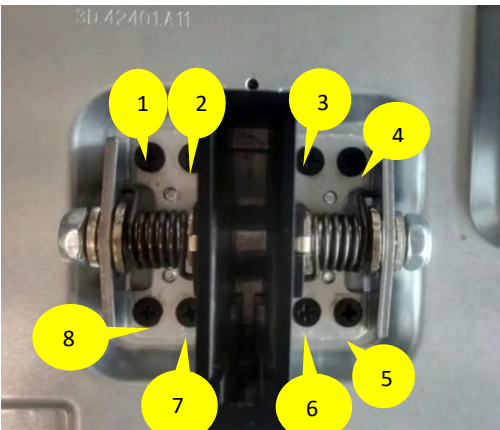
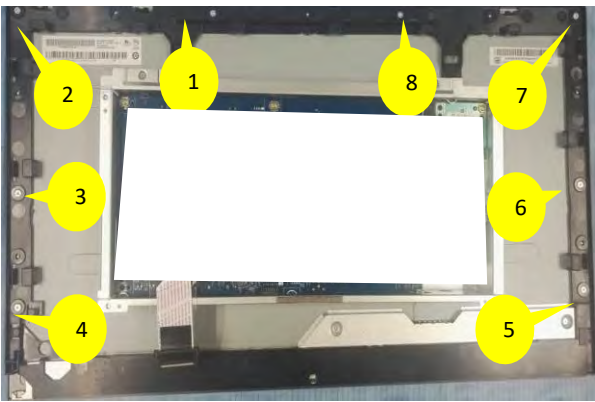
<p>4</p>		<ol style="list-style-type: none"> 1. Remove 1 pcs conduct tape from RC 2. Disassemble LED BD from RC and remove LED BD and LED cable 3. Remove LED cable from LED BD 4. Unlock 2 pcs screws 5. Disassemble LENS BD and CTRL BD from RC 6. Remove CTRL cable from CTRL BD 7. Remove cable from LENS BD and CTRL BD 	<p>Screw-driver</p>	<p>4.5±0.5kg</p>
<p>5</p>		<ol style="list-style-type: none"> 1. Unlock 8 pcs screws 	<p>Screw-driver</p>	<p>8-10kg</p>
<p>6</p>		<ol style="list-style-type: none"> 1. Unlock 8 pcs screws 2. Remove middle frame from panel 	<p>Screw-driver</p>	<p>4.5±0.5kg</p>

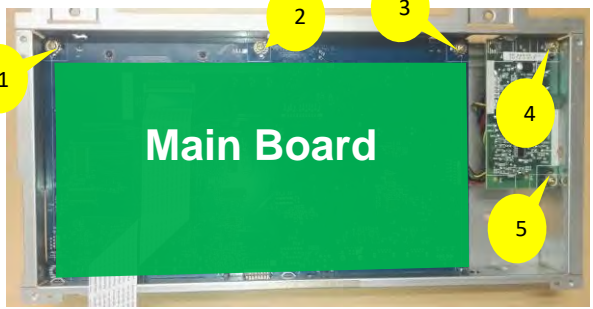
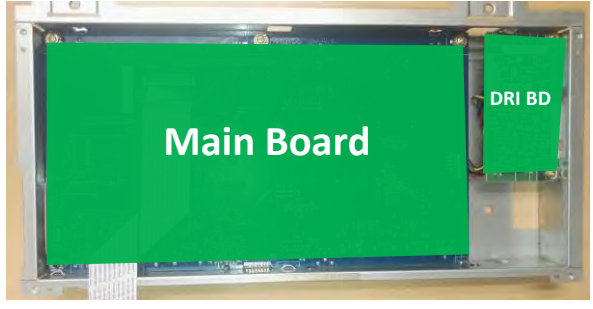
8	 <p>The image shows the main board assembly with a green overlay. Five yellow callout circles are numbered 1 through 5. Callout 1 points to a screw on the left edge. Callouts 2 and 3 point to screws on the top edge. Callouts 4 and 5 point to screws on the right edge.</p>	<ol style="list-style-type: none"> 1. Unlock 5 pcs screws 2. Remove FFC cable from IF BD 	Screw-driver	6~8KG
9	 <p>The image shows the main board assembly with a green overlay. A callout labeled 'DRI BD' points to a component on the right side of the board.</p>	<ol style="list-style-type: none"> 1. Disassemble IF BD and DRV BD from SHD 2. Disassemble DRV cable from IF BD 		

Main board- Connector repair

Repair Condition: Connector repair is only for the monitor that has been out of warranty period.

- The repair procedure is for HDMI, DisplayPort and audio connectors.
- The connectors are on the main board (IF board part number 5E.49H01.011).
- Please refer to the location to repair the correct parts:

Connector	Location
Audio	J11
USB A 3.0	J5, J6
USB B 3.0	J4
HDMI	J8, J9
DisplayPort (DP)	J7

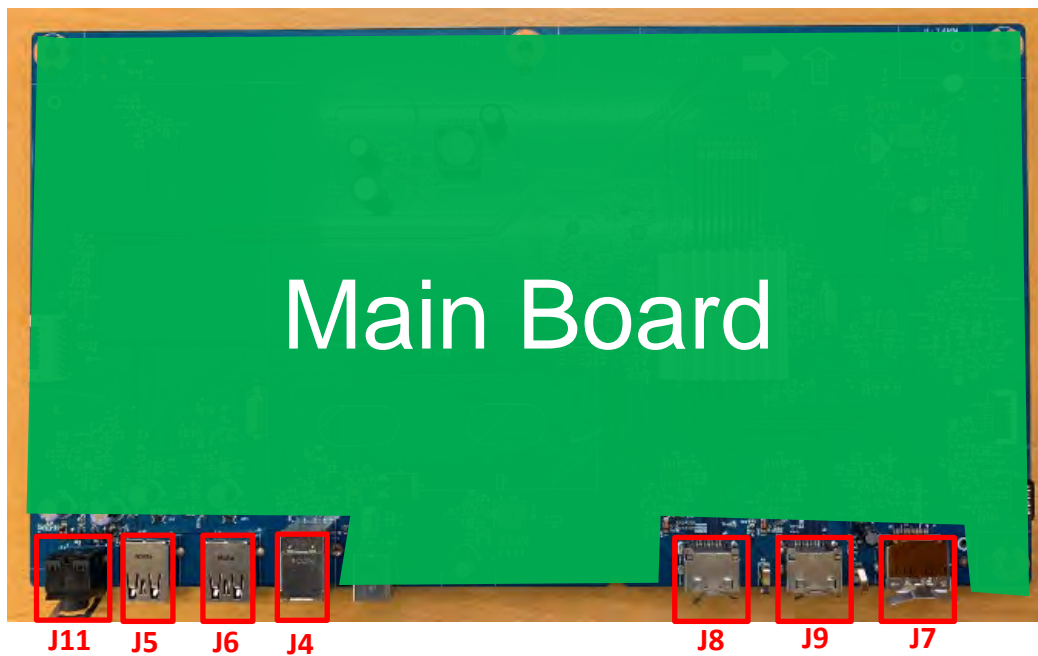

IMPORTANT:

- **Repair Condition: Connector repair is only for out of warranty.**
- **Repairing must operate by professional repairers (Note) in repair center, not applicable for end user.**
- **Electrostatic protection is required when component replacement is required.**
- **The monitor meets ROHS, please use Lead-free solder wire for soldering.**
- **If Connector need to replace, must check specification and part number whether match the BOM and location.**
- **If connector need to replace, please insert new parts carefully because the near pin may cause short circuit by inappropriate operate.**
- **DO NOT allow any liquid on the board. Water and moisture may cause short-circuit to the electronic components and lead to malfunctions.**
- **The fusion point of Lead-Free solder is requested. Repairing with conventional lead wire may cause damage.**
- **Work quickly to avoid overheating the circuit board as soon as you confirm the steady soldering condition.**
- **Keep the soldering iron tip clean and well tinned and when replacing parts.**
- **A close inspection of the circuit board revealed look in good condition.**
- **After repaired, must connect source to each port to check Main board function is ordinary.**

Note: (The requirement of professional repairers' regulation by ERP lot5)

- (1) The professional repairer has the technical competence to repair electronic displays and complies with the applicable regulations for repairers of electrical equipment in the Member States where it operates. Reference to an official registration system as professional repairer, where such system exists in the Member States concerned, shall be accepted as proof of compliance with this point.
- (2) The professional repairer is covered by insurance covering liabilities resulting from its activity, regardless of whether this is required by the Member State.

Audio Connector repair- J11

- 1) Use a hot air gun to melt the solder on the pins Pin solder with soldering iron and absorber.

You can gently push down with the soldering iron once everything is molten to move the M1 out of the through holes



- 2). Lift M1 from the PCB
- 3). Place new component on the location, and must check it can match PCB footprint
- 4). Soldering the new component by solder iron

USB A 3.0 Connector repair- J5, J6

- 1) Use a hot air gun to melt the solder on the pins Pin solder with soldering iron and absorber.

You can gently push down with the soldering iron once everything is molten to move the connector out of the through holes

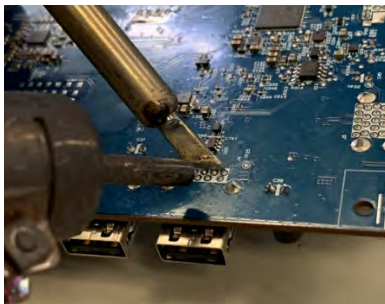
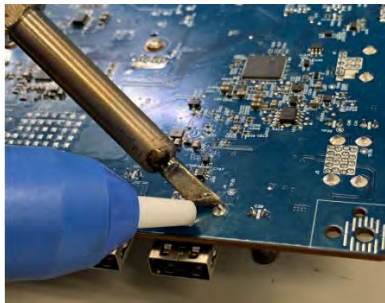

- 2). Lift connector from the PCB
- 3). Place new component on the location, and must check it can match PCB footprint
- 4). Soldering the new component by solder iron

USB B 3.0 Connector repair- J4

- 1) Use a hot air gun to melt the solder on the pins Pin solder with soldering iron and absorber.

You can gently push down with the soldering iron once everything is molten to move the connector out of the through holes

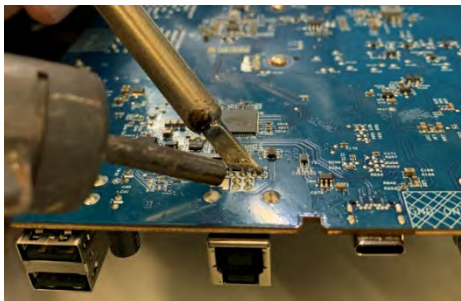
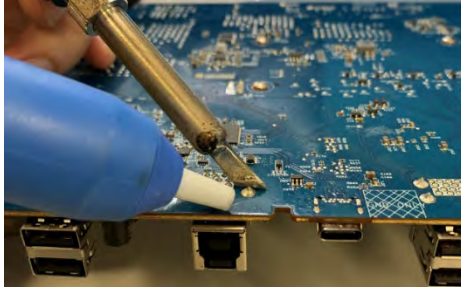

- 2). Lift connector from the PCB
- 3). Place new component on the location, and must check it can match PCB footprint
- 4). Soldering the new component by solder iron

HDMI Connector repair- J8, J9

- 1) Use a soldering iron and a de-soldering pump to remove as much solder as possible from one of the pin.

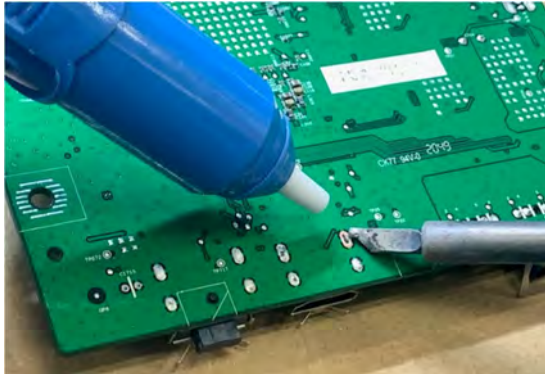

- 2) Use a hot air gun to melt the solder on the pins



- 3). Lift J2 from the PCB
- 4). Place new component on the location, and must check it can match PCB footprint
- 5). Soldering the new component by solder iron
- 6). Please must stick a gasket on the Shielding. Find the procedure on page 22.

DP Connector repair- J7

- 1) Use a soldering iron and a de-soldering pump to remove as much solder as possible from one of the pin.

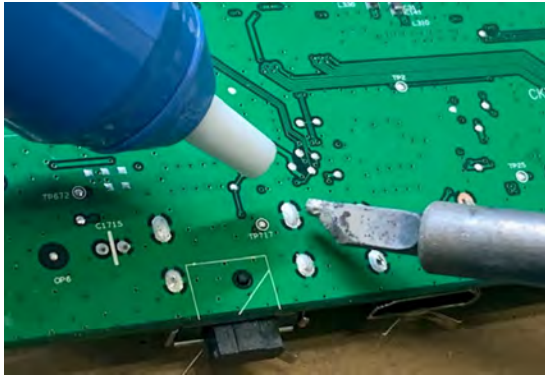

- 2) Use a hot air gun to melt the solder on the pins

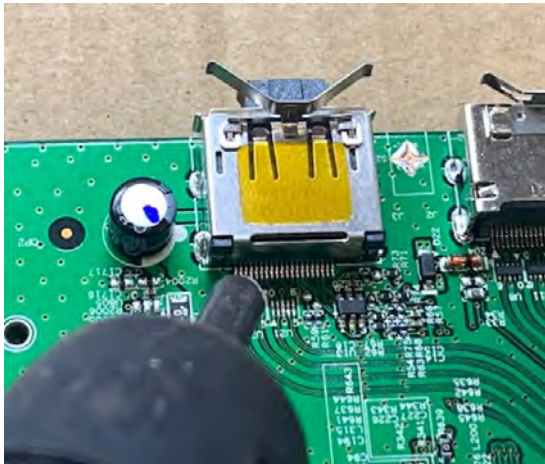

- 3) Lift J3 from the PCB
- 4) Place new component on the location, and must check it can match PCB footprint
- 5) Soldering the new component by solder iron
- 6) Tear off the yellow tape on the DP connector, so that it can contact to the gasket, EMI will be effective.

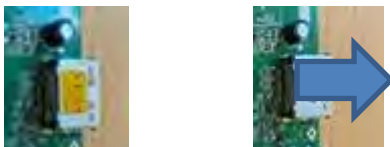

- 7). Please must stick a gasket on the Shielding. Find the procedure on page 22.

Stick Gasket on the Shielding

1) Use scissors to cut the length of gasket 3020812 in 20mm.

Gasket Size: W 8mm x H 12mm x L 20mm

(The Length of gasket should not be less than 20mm)

2) Remove the tape on the gasket and align the gasket to the right side of the HDMI or DP.

(Alignment refers to the yellow arrow in the image below)

3) Press the gasket to the end of shielding with your fingers and confirm that it will not fall.

If the gasket falls on the inner boards, it will cause a short circuit and damage the Monitor.

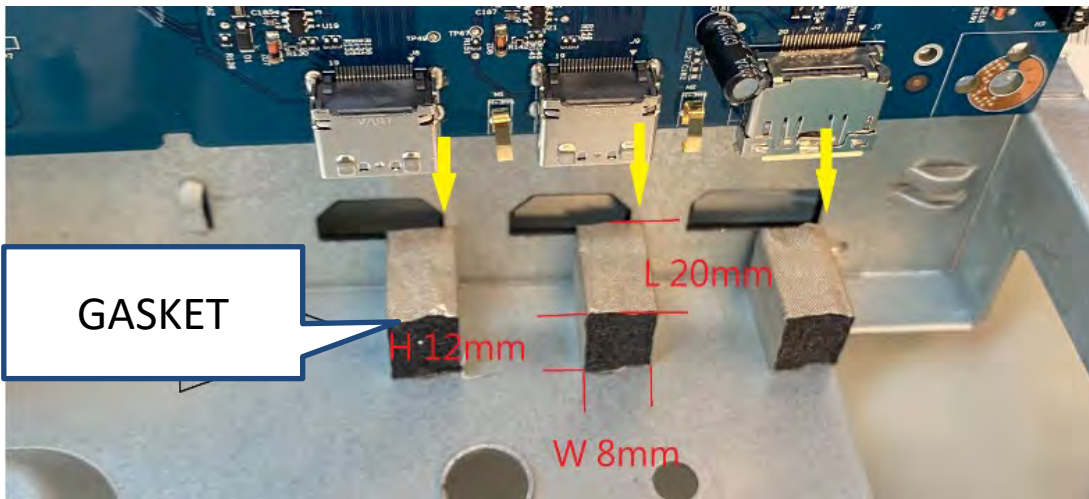

4) After assembly, check from the appearance whether the connector is indeed fixed with the gasket.



Function Test:

After repairing, please do the function test to check all functions are working.

Test Item	OPERATION DESCRIPTIONS	EQUIP.OR TOOL USED
HDMI test	Check if the image and sound can be played normally on monitor. No noise volume and balance is correct.	PC or DVD Player
DP test	Check if the image and sound can be played normally on monitor. No noise volume and balance is correct.	PC or DVD Player
Audio test	Change sound volume and balance if the volume sound smoothly and loud enough.	Speaker

Support and Troubleshooting

Solving common problems

The following table lists possible problems, the possible cause of each problem, and the recommended solutions.

Problem	Possible Cause	Solution
Screen is blank or video is flashing.	Power cord is disconnected.	Connect the power cord.
	Monitor is off.	Press the Power button. NOTE: If pressing the Power button has no effect, press and hold the power button for 10 seconds to disable the Power button lockout feature.
	Video cable is improperly connected.	Connect the video cable properly. See Connecting the cables on page 5 for more information.
	System is in sleep mode.	Press any key on the keyboard or move the mouse to exit sleep mode.
Image appears blurred, indistinct, or too dark.	Video card is incompatible.	Open the OSD menu and select the Input Control menu. Set Auto-Switch Input to Off and manually select the input.
	Brightness is too low.	Open the OSD menu and select Brightness to adjust the brightness scale as needed.
Check Video Cable is displayed on screen.	Monitor video cable is disconnected.	Connect the appropriate video signal cable between the computer and monitor. Be sure that the computer power is off while you connect the video cable.
Input Signal Out of Range is displayed on screen.	Video resolution and/or refresh rate are set higher than what the monitor supports.	Change the settings to a supported setting. See Preset display resolutions on page 17 for more information.
The monitor is off but it did not seem to enter into sleep mode.	The monitor's power saving control is disabled.	Open the OSD menu and select Power Control > Auto-Sleep Mode and set auto-sleep to On .
On-Screen Menus are Locked is displayed.	The monitor's OSD lock function is enabled.	Press and hold the Menu button on the front bezel for 10 seconds to disable the OSD lockout function.
Power Button is Locked is displayed.	The monitor's power button is locked.	Press and hold the power button for 10 seconds to disable the power button lock function.

Index

components

front, 3

rear, 4

DisplayPort connector location, 4

features, 2

front components, 3

function button locations, 3

HDMI connector location, 4

illustrated parts catalog, 7

menu button location, 3

parts, 7

power board removal, 12

power button location, 3

power connector location, 4

power light location, 3

preparation for disassembly, 9

RC removal, 9

rear components, 4

removal

power board, 12

RC, 9

xxxx, 14

removal and replacement procedures, 9

RoHS (2002/95/EC) requirements, 1

safety information, 1

serial number location, 5

spare parts, 7

USB port location, 4

USB upstream port location, 4

VGA connector location, 4

xxxx removal, 14