

Reference Guide

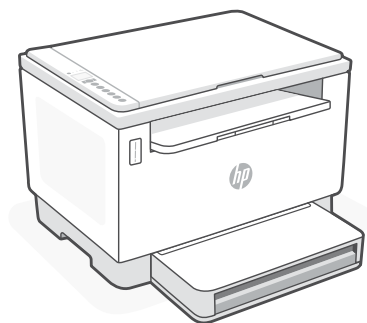

HP LaserJet Tank MFP 1005 series

打印机功能

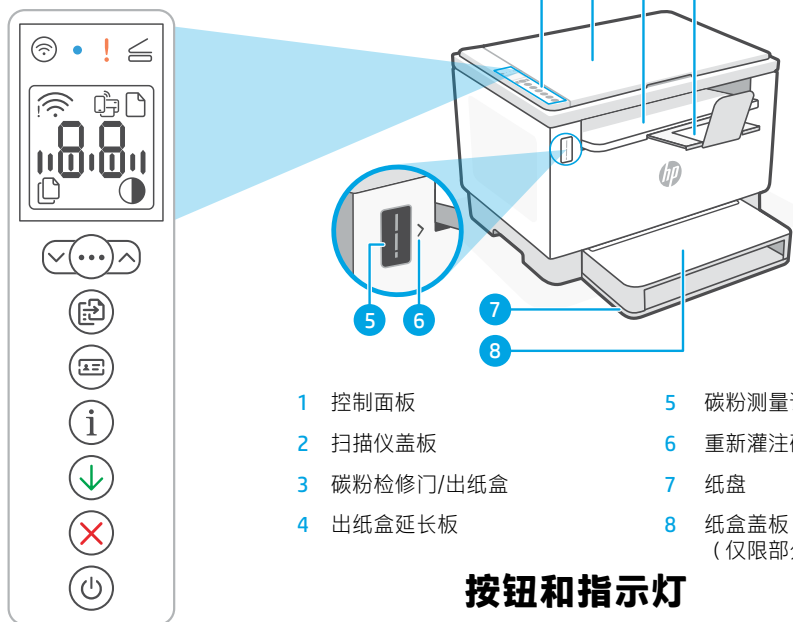











- | | |
|-------------|--------------------|
| 1 控制面板 | 5 碳粉测量计 |
| 2 扫描仪盖板 | 6 重新灌注碳粉指示器 |
| 3 碳粉检修门/出纸盒 | 7 纸盘 |
| 4 出纸盒延长板 | 8 纸盒盖板
(仅限部分机型) |

按钮和指示灯

显示屏图标

-  **无线警报**
Wi-Fi 已连接。重新启动设置模式。
-  **Wi-Fi Direct 状态**
-  **纸张问题**
放入纸张/检查是否卡纸。
-  **字符显示**
份数、错误代码、对比度等级。参阅在线使用手册。
-  **份数指示器**
-  **变淡/变暗 (对比度) 图标**

-  **Wi-Fi 按钮/指示灯**
按下此按钮可开关 Wi-Fi。Wi-Fi 指示灯用于指示状态。
-  **Wi-Fi 指示灯**
正在建立连接时闪烁。已连接后亮起。
-  **警示指示灯**
-  **打开扫描仪盖指示灯**
-  **打开扫描仪盖**指示灯
打开盖子并翻转身份证以复印第二面。
-  **复印选项按钮/指示灯**
-  **身份证复印按钮/指示灯**
-  **信息按钮/指示灯**
按下即可打印打印机设置和状态的摘要。
-  **重新开始按钮/指示灯**
亮起时按下即可继续完成作业。
-  **取消按钮/指示灯**
-  **电源按钮/指示灯**
正在启动或处理作业时闪烁。

有关指示灯和错误的详细信息，请访问 hp.com/support

检查碳粉余量

打印机在购买时已预灌注碳粉。HP 碳粉重新灌注套件 (TRK) 提供 2 种选项：标准容量和大容量。碳粉测量计上测量条的值为估算碳粉量，可能与实际碳粉量略有不同。

检查碳粉测量计指示器，确定何时添加碳粉。要购买 HP 原装碳粉包，请访问 hp.com/buy/supplies 或咨询当地的 HP 分销商。

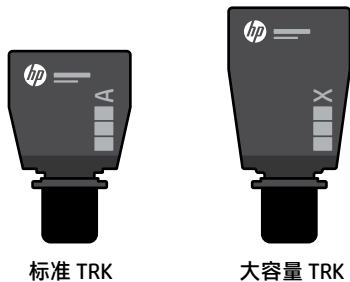

碳粉余量指示器状态

查看碳粉余量

碳粉几乎装满



碳粉已部分耗尽



碳粉余量低，但仍可继续打印。

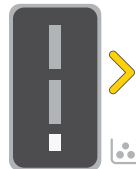

碳粉余量极低。无法打印。



碳粉余量极低时，箭头呈琥珀色闪烁。

加装智能闪充粉盒 (TRK)

不能再添加碳粉

可加装 1 个标准 TRK

可加装 1 个大容量 TRK 或 2 个标准 TRK。

必须加装 1 个大容量 TRK 或 2 个标准 TRK。

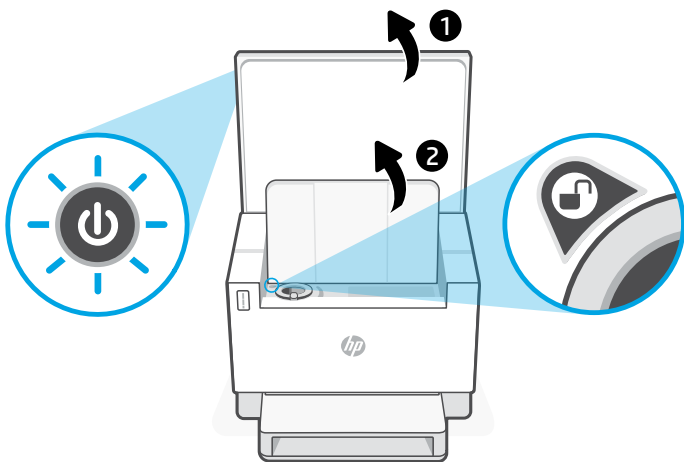

只有在端口指示器显示解锁图标 (🔓) 时，才能添加碳粉。有关更多信息，请参阅用户指南，网址：hp.com/support

Wi-Fi 及连接帮助与提示

如果软件在设置过程中未能找到打印机，请检查以下情况以解决问题。

潜在问题

解决方案

打印机 Wi-Fi 设置模式超时（无线指示灯未闪烁）

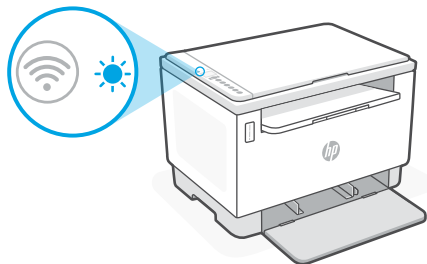

如果“无线”指示灯未呈蓝色闪烁，则说明打印机可能未进入 Wi-Fi 设置模式。重新启动设置模式：

1. 如果控制面板未点亮，请按下 ⊗ 退出睡眠模式。
2. 按住 ① 5 秒钟，然后在所有控制面板按钮亮起后释放。
3. 同时按下 ⊕ 和 ⊗ 一次，然后释放这两个按钮。等待一分钟，直至无线指示灯闪烁。
4. 关闭并重新打开 HP Smart，然后尝试重新连接。

计算机或移动设备离打印机过远

将计算机或移动设备靠近打印机。设备可能已超出打印机的 Wi-Fi 信号范围。

计算机已连接至虚拟专用网络 (VPN) 或远程工作网络

请先断开 VPN，然后再安装 HP Smart 软件。与 VPN 连接时，无法通过 Microsoft Store 安装应用。完成打印机设置后再连接 VPN。

注意：在断开 VPN 连接之前，请考虑您的位置和 Wi-Fi 网络的安全性。

计算机上的 Wi-Fi 已关闭
(计算机通过以太网连接)

如果计算机通过以太网连接，请在设置打印机时开启计算机的 Wi-Fi。暂时断开以太网电缆，以便通过 Wi-Fi 完成设置。

计算机或移动设备上的蓝牙已关闭。

开启正在使用的设备的蓝牙，以完成设置。对于移动设备，还应开启定位服务。蓝牙和定位功能有助于软件找到您的网络和打印机。

移动设备上的定位功能已关闭。

注意：我们不会确定您的位置，设置过程中，也不会将位置信息发送到 HP。



帮助和支持

如需了解打印机故障排除相关信息和观看视频，请访问 HP 支持网站。输入您的型号名称以查找打印机。







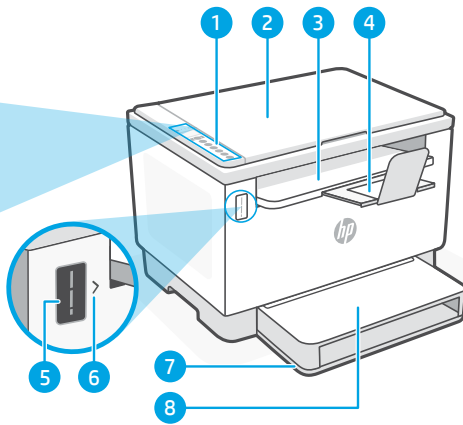

hp.com/support

Printer features













- | | |
|-----------------------------------|---------------------------------|
| 1 Control Panel | 5 Toner gauge |
| 2 Scanner lid | 6 Refill toner indicator |
| 3 Toner access door / Output tray | 7 Paper tray |
| 4 Output tray extender | 8 Tray cover (some models only) |

Display icons

-  **Wireless alert**
Wi-Fi is disconnected. Restart setup mode.
-  **Wi-Fi Direct status**
-  **Paper problem**
Load paper/check for jams.
-  **Character display**
Number of copies, error code, contrast levels. See the online user guide.
-  **Number of Copies indicator**
-  **Lighter/Darker (contrast) icon**

Button and lights

-  **Wi-Fi button/light**
Press to turn on/off Wi-Fi. The Wi-Fi light indicates the status.
-  **Wi-Fi light**
Blinks when connecting. Lit when connected.
-  **Attention light**
-  **Open Scanner Lid light**
Open lid and turn over ID card to copy second side.
-  **Copy Options button/light**
-  **Start Copy button/light**
-  **ID Card Copy button/light**
-  **Information button/light**
Press to print a summary of printer settings and status.
-  **Resume button/light**
Press when lit to continue a job.
-  **Cancel button/light**
-  **Power button/light**
Blinks when starting or processing a job.

For more information on lights and errors, visit hp.com/support

Check toner level

The printer is pre-filled with toner at purchase. HP toner refill kits (TRK) are available in 2 options: Standard and High capacity. The value of bars on the toner gauge are estimated toner levels and may vary slightly from the actual toner level.

Check the toner gauge indicator to determine when to add toner. Purchase original HP toner packs from hp.com/buy/supplies or your local HP reseller.

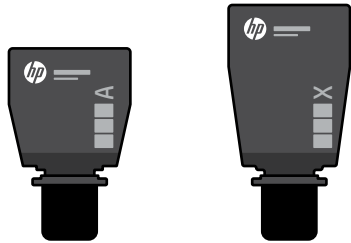

Standard TRK

High Capacity TRK

Toner level indicator states

View toner level

Toner is almost full



Toner is partly depleted



Toner level is low, but printing can continue.



Toner level is very low. Unable to print.



Arrow blinks amber when the toner level is very low.

Add toner reload kit (TRK)

No more toner must be added

1 Standard TRK can be added

1 High Capacity TRK or 2 Standard TRK can be added.

1 High Capacity TRK or 2 Standard TRK must be added.

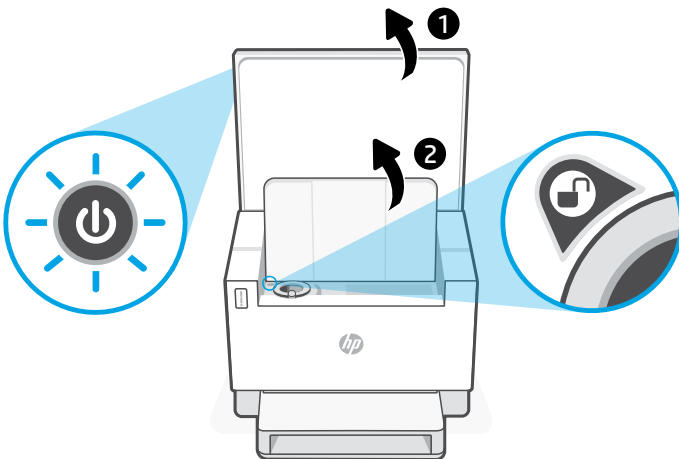

Toner can be added only when the port indicator shows an **unlock** icon (🔓). For more information, see the User Guide at hp.com/support

Help and tips for Wi-Fi and connectivity

If the software is unable to find your printer during setup, check the following conditions to resolve the issue.



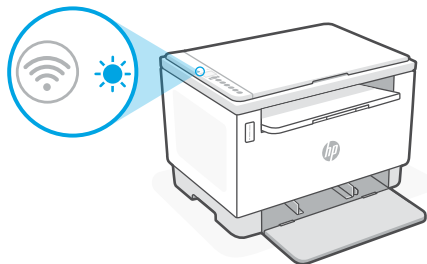

Potential Issue

Solution

Printer Wi-Fi setup mode timed out (Wireless light not blinking)



If the Wireless light is not blinking blue, the printer might not be in Wi-Fi setup mode. Restart setup mode:

1. If the control panel is not lit, press  to exit sleep mode.
2. Press and hold  for 5 seconds, then release once all the control panel buttons light up.
3. Press  and  at the same time once and then release the buttons. Wait for one minute until the Wireless light blinks blue.
4. Close and reopen HP Smart and try connecting again.

Computer or mobile device too far from printer

Move your computer or mobile device closer to the printer. Your device might be out of range of the printer's Wi-Fi signal.

Computer connected to a Virtual Private Network (VPN) or remote work network

Disconnect from a VPN before installing HP Smart software. You can't install apps from the Microsoft Store when connected to a VPN. Connect to the VPN again after finishing printer setup.

Note: Consider your location and the security of the Wi-Fi network before disconnecting from a VPN.

Wi-Fi turned off on computer (computer connected by Ethernet)

If your computer is connected by Ethernet, turn on the computer's Wi-Fi while setting up the printer. Disconnect the Ethernet cable temporarily to complete setup over Wi-Fi.

Bluetooth is turned off on your computer or mobile device

Turn on Bluetooth for the device being used to complete setup. For mobile devices, turn on Location services also. Bluetooth and Location help the software find your network and printer.

Location is turned off on your mobile device

Note: Your location is not being determined and no location information is being sent to HP as part of the setup process.



Help and Support

For printer troubleshooting and videos, visit the HP support site. Enter your model name to find the printer.



hp.com/support



© Copyright 2021 HP Development Company, L.P.

Microsoft and Windows are either registered trademarks or trademarks of Microsoft Corporation in the United States and/or other countries. Mac, OS X, macOS, and AirPrint are trademarks of Apple Inc., registered in the U.S. and other countries. Android is a trademarks of Google LLC. iOS is a trademark or registered trademark of Cisco in the U.S. and other countries and is used under license.



ZHCN EN

越南印刷

Printed in Vietnam

381U4-90012