



HP Latex 2700 Printer Series Site Preparation Guide

SUMMARY

You are responsible for preparing the physical site for the installation of the printer.

About this edition

© Copyright 2022 HP Development Company, L.P.

Edition 1, May 2022

Legal notices

The information contained herein is subject to change without notice.

The only warranties for HP products and services are set forth in the express warranty statement accompanying such products and services. Nothing herein should be construed as constituting an additional warranty. HP shall not be liable for technical or editorial errors or omissions contained herein.

Table of contents

1 Introduction	1
Documentation and useful links.....	1
Site preparation overview.....	1
Customer responsibility	2
Planning the site and printer environment	2
RIP installation.....	3
Networking.....	3
Printing supplies for testing and training.....	3
Return the site preparation checklist.....	3
Recycle the disposable ink bag and printhead cleaning roll	4
Recycle the printheads.....	4
Liquid waste disposal	4
2 Site preparation.....	5
Installation time schedule.....	5
Electrical configuration.....	6
Power distribution unit (PDU).....	7
Power specifications.....	7
Circuit breakers (required).....	10
Power cables.....	11
Powerline disturbances.....	11
Grounding.....	11
Air supply requirements (pneumatic spindle).....	12
Room requirements.....	12
Temperature and humidity	12
Ventilation	13
Local exhaust.....	13
Air conditioning.....	14
Load bearing	14
Floor surface	15
Lighting	16
Designing the print production area	16
Fire-fighting equipment	16
Optimal room layout.....	16
Storage area for materials.....	17

Storage conditions for substrate rolls	18
Computer and networking requirements.....	18
RIP requirements	19
External color profiling	20
3 Shipment arrival preparation	21
Unloading area.....	21
Route from unloading site to installation site	21
Shipment items	22
Tools and manpower required for installation	22
Moving equipment	22
Ground-floor installation	22
Lower the printer with ramps	23
Lower the printer with forklift	23
Above-ground-floor installation.....	25
Waste disposal.....	26
4 Site preparation checklist	27
How to create a Site Preparation.....	27
How to create Site preparation in SC4CH Mobile App.....	27
How to create Site preparation in SC4CH Desktop App.....	29
Fill the Site preparation	31
Manually	31
SC4CH Mobile app	31
How to upload Site preparation in SC4CH Mobile App	40
If the Site Preparation is completed Manually	40
If the Site Preparation is completed in PrintOS	42
5 Complete the checklist on paper	44
Checklist.....	44

1 Introduction

Your printer is supplied almost fully assembled and ready for the simple installation procedures described in detail in the installation guide.

It comes complete with printheads and a printhead cleaning roll.

Documentation and useful links

A full set of manuals are available for your printer.

The following documents can be downloaded from <http://www.hp.com/go/latex2700/manuals>:

- Site preparation guide and checklist (this document)
- Installation guide
- Introductory information
- User guide
- Legal information
- Limited warranty

Further information is available from <http://www.hp.com/go/latex2700/support>.

Videos and other training materials are available from:

- <http://www.hp.com/supportvideos>
- <http://www.youtube.com/HPPrinterSupport>
- <https://lkc.hp.com/blog/hp-latex-2700-printer-series-training>

See the Solutions website for information about new substrates, at <http://www.hp.com/go/latex2700/solutions/>. A new Web-based Media Solutions Locator (<http://www.hp.com/go/mediasolutionslocator>) has been developed to collect available substrate configurations for latex printers.

Site preparation overview

This guide should assist you in preparing for your installation.

In particular:

- Modifications to the installation area

- Site accessibility
- Emergency exits
- Planning the print production area
- Mechanical, electrical and environmental specifications
- Computer and network connectivity
- Contracting a specialist mover with a forklift and/or suitable moving equipment; needed only if the site does not comply with the specifications to download the printer with the provided ramps
- Contracting an electrician
- Environmental health and safety

All information in this guide is provided on the assumption that installation planners and personnel are familiar with:

- Architectural and planning requirements
- Applicable laws, regulations, and standards



NOTE: It is important to read the information provided in this guide thoroughly and ensure complete compliance with all installation and operation prerequisites, safety procedures, warnings, cautions, and local regulations.

Customer responsibility

You are responsible for completing all preparations before the day of installation.

Planning the site and printer environment

You must complete the following tasks:

- Prepare the site for unloading. See [Unloading area on page 21](#).
- Make sure the route from the unloading site to the installation site meets specifications. See [Route from unloading site to installation site on page 21](#).
- Make sure you have the necessary equipment to handle the printer, as well as a specialist mover who is familiar with your site and the information provided in this guide. See [Moving equipment on page 22](#).
- Meet the requirements for upper-level installations (if necessary). See [Above-ground-floor installation on page 25](#).
- Configure the building's electrical system used to power the printer to meet the printer's requirements and the Electrical Code requirements of the local jurisdiction of the country where the equipment is installed. A qualified electrician is required to power up the printer on the day of installation. See [Electrical configuration on page 6](#).
- Provide an adequate air supply for the pneumatic spindles. See [Air supply requirements \(pneumatic spindle\) on page 12](#).
- Meet temperature and humidity requirements and ensure proper ventilation for the printer. See [Air conditioning on page 14](#) and [Temperature and humidity on page 12](#).

- Material and supplies storage, handling, and disposal should be performed as per local laws. See the Safety Data Sheets at <http://www.hp.com/go/msds> for adequate handling and storage. Follow your Environmental Health and Safety processes and procedures.
- Supply all necessary emergency equipment. See [Fire-fighting equipment on page 16](#).
- Ensure that the room in which the system is installed meets local environmental, health, and safety (EHS) guidelines and regulations.

RIP installation

If you have bought RIP software for your printer, this guide does not provide information about it.

However:

- You must install the RIP on a suitable computer and ensure that it is fully functional by the agreed date of printer installation.
- For full functionality, HP recommends that the computer is connected to the Internet.

Networking

You are responsible for all networking requirements.



NOTE: In order to perform remote support, the printer must have access to the Internet using the LAN connection.

You must complete the following tasks:

- Have an adequate network ready for the day of installation. See [Computer and networking requirements on page 18](#).
- Provide a CAT-6 LAN cable to connect the printer to your LAN on the day of installation.

Printing supplies for testing and training

You are responsible for providing printing supplies for use at installation time.

The following supplies will be needed:

- Eight ink cartridges for the 2700 printer, or nine for the 2700W printer.



NOTE: In addition, you are recommended to have a second set of ink cartridges, printheads, and one HP Latex Cleaning Roll, in case any replacements are needed.

- Compressed air supply for the pneumatic spindle (see [Air supply requirements \(pneumatic spindle\) on page 12](#))
- Substrate for printing—preferably the substrate type that you plan to use most in future
- 10 liters of distilled water
- Self-adhesive vinyl substrate for the printhead alignment process, to be done during installation

Return the site preparation checklist

The checklist must be completed and returned to your reseller or service representative a minimum of two weeks before the day of installation.



NOTE: Any delays during installation that are caused by an unprepared site will be charged to the customer. Take care that your site is properly prepared to ensure a smooth and easy installation.

Recycle the disposable ink bag and printhead cleaning roll

These items require disposal according to local regulations.

For further information, see the MSDS document about your printer's ink, available from <http://www.hp.com/go/msds>.

Recycle the printheads

The printheads require disposal according to local regulations.

For further information, see the MSDS document about your printer's ink, available from <http://www.hp.com/go/msds>. Within some countries covered by HP Planet Partners Returns, HP is offering a recycling program. For full details of this program, see <http://www.hp.com/recycle/>.

Liquid waste disposal

Dispose of liquid waste in compliance with all applicable federal, state, and local regulations.

HP can provide a typical Waste Profile Datasheet to assist you with disposal decisions.

2 Site preparation

The site should be prepared in advance so that it is ready for installation when the printer is delivered.

Take into consideration any structural modifications required and the time required for submission and approval of plans to the relevant local authorities. Secure temporary storage for the shipping package prior to equipment installation may also be necessary.

⚠ CAUTION: All cables connected to the printer should be contained within suitable conduits; these may be overhead or channeled into the floor, as appropriate. Tripping over loose wires or cables can cause personal injury and/or damage to the equipment.

Installation time schedule

The best method to ensure a smooth and trouble-free installation process is proper site preparation.

The following time schedule estimate is based on the assumption that all system components have been delivered in proper working order and all site preparation and planning requirements have been met and completed in accordance with the specifications provided in this guide. The installation process is divided into two phases:

Installation time schedule

	Time to completion
Installation and system configuration	2.5 full working days
Operation and maintenance training	2.5 full working days

Although the optimal time schedule requires approximately 5 working days, it may be necessary to schedule additional time for either phase. Please plan ahead for any special circumstances that may occur during the installation process, and do not plan for production during installation and training.

If the RIP software is bought from HP, the training will cover the normal use of the RIP. The following aspects of RIP usage will be covered:

HP Large Format Onyx Thrive RIP software

- RIP-Queue
- Configure the printer (Quickset, Device output, Substrate, Page size, Properties)
- Main items of the Job Editor (Printer and substrate selection, Preview and size, Tiling setup, Color correction, Print)

The Media Manager will not be covered.

HP Large Format Caldera Grand RIP software

- Server Administration (Server, Configure, Connection)
- GrandRIP+ (Main, Tool, Settings)
- Spooler
- Image Work Directory (Image positioning and scale setting on the page, and so on)

Profile creation will not be covered.

Electrical configuration

An electrician is required for the setup and configuration of the building electrical system used to power the printer, and also for printer installation.

Make sure that your electrician is appropriately certified according to local regulations and supplied with all the information regarding the electrical configuration.

The HP Internal Print Server can be powered with a single-phase line that can be used with an Uninterruptible Power Supply (UPS). The UPS must be rated to meet the power requirements of the printer, and should be in accordance with the wiring standards of the country of installation.

If you intend to split the input power between a 3-phase branch and a 1-phase (UPS) branch, you should use a UPS with a minimum specification of 500 VA and 250 W.

The printer requires the following electrical components to be supplied and installed by the customer, according to the Electrical Code requirements of the local jurisdiction of the country of installation.

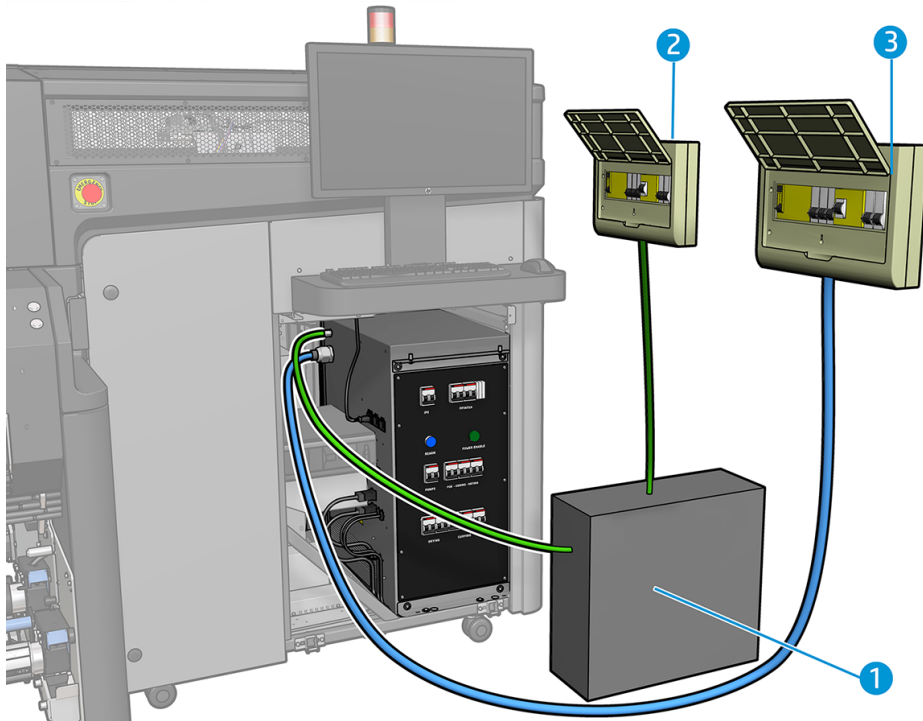

- Uninterruptible Power Supply (UPS) for single-phase control line (optional)

 **NOTE:** The HP Internal Print Server power can be obtained by making a connection inside the electrical cabinet.

- Power Distribution Unit (PDU) including single-phase branch circuit breaker (optional)
- Power Distribution Unit (PDU) including three-phase branch circuit breaker (depending on the power configuration)

 **NOTE:** Remember that you are required to follow the local laws, regulations, and standards that apply to the electrical installation of your printer.

 **NOTE:** The printer is not supplied with any power cable.

Power distribution unit (PDU)

The PDU must be rated to meet the power requirements of the printer, and should be in accordance with the Electrical Code requirements of the local jurisdiction of the country where the equipment is installed.

Power specifications

Four different power-supply configurations are supported.

Configuration 1: 380–415 V line-to-line three-phase configuration

This configuration is specified in detail below.

Three-phase specifications

Number of power wires	5 (L1/L2/L3/N/PE)
Input voltage (line to line)	380–415 V~
Input frequency	50/60 Hz
Maximum load current (per phase)	35 A

Branch circuit breaker specifications

Three-phase	4 poles, 40/50 A
-------------	------------------

AC power cable specifications

Configuration	5 wires, L1/L2/L3/N/PE
Wire	Strained Cu32 minimum, 10 mm ² (8 AWG)
Terminals	Lines, ferrule terminals, PE, M8 ring terminal
External diameter range	22.0–33.0 mm

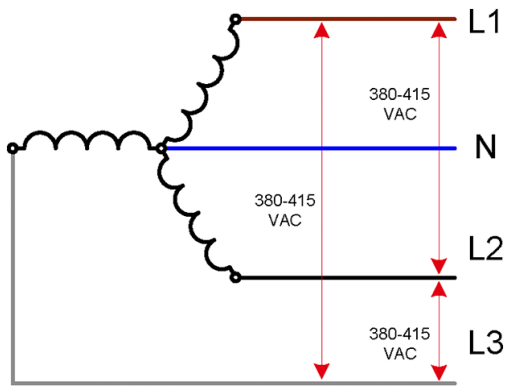

Configuration 2: 200–240 V line-to-line three-phase configuration

This configuration is specified in detail below.

Three-phase specifications

Number of power wires)	4 (L1/L2/L3/PE)
Input voltage (line to line)	200–240 V
Input frequency	50/60 Hz
Maximum load current (per phase)	56 A

Branch circuit breaker specifications

Three-phase	3 poles, 63/70 A
-------------	------------------

AC power cable specifications

Configuration	4 wires, L1/L2/L3/PE
Wire	Strained Cu minimum, 10 mm ² (6 AWG)
Terminals	Lines, ferrule terminals, PE, M8 ring terminal
External diameter range	22.0–33.0 mm

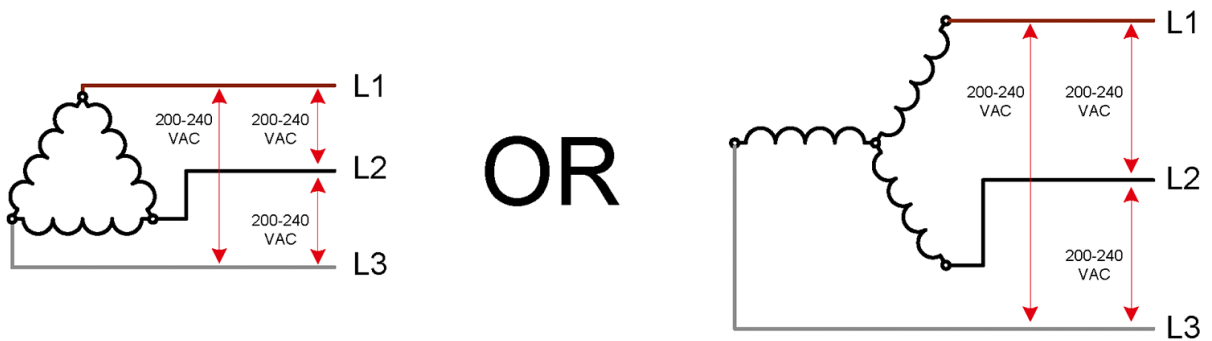

Configuration 3: 380–415 V line-to-line three-phase configuration with single- phase control

This configuration is specified in detail below.

Specifications

	Three-phase line	Single-phase control
Number of power wires	5 (L1/L2/L3/N/PE)	3 (L/N/PE)
Input voltage (line to line)	380–415 V~ (-10%)	100–240 V
Input frequency	50/60 Hz	50/60 Hz
Maximum load current (per phase)	35 A	10 A

Branch circuit breaker specifications

Three-phase	4 poles, 40/50 A
Two-phase control	2 poles, 15/16/20 A

AC power cable specifications

	Three-phase line	Single-phase line
Configuration	5 wires, L1/L2/L3/N/PE	3 wires, L/N/PE
Wire	Strained Cu minimum, 10 mm ² (8 AWG)	Strained Cu minimum, 1.5 mm ² (16 AWG)
Terminals	Lines, ferrule terminals, PE, M8 ring terminal	Lines, ferrule terminals, PE, M4 ring terminal
External diameter range	22.0–33.0 mm	5.0–11.0 mm

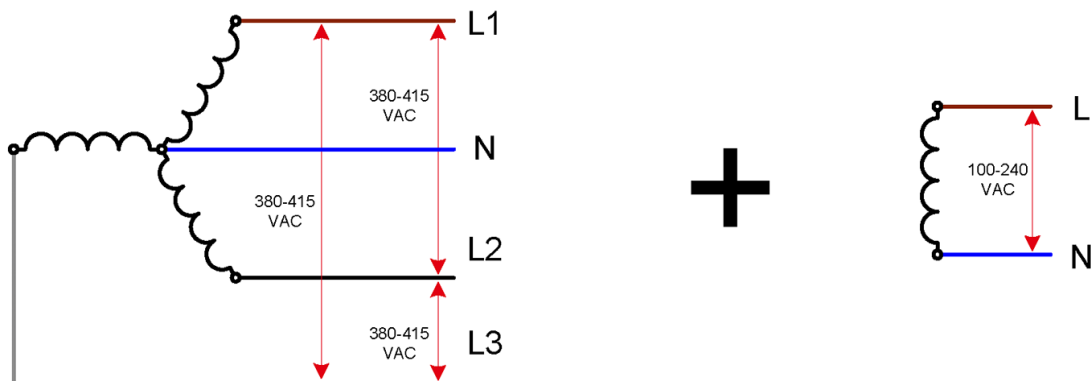

Configuration 4: 200–240 V line-to-line three-phase configuration with single- phase control

This configuration is specified in detail below.

Specifications

	Three-phase line	Single-phase control
Number of power wires	4 (L1/L2/L3/PE)	3 (L/N/PE)
Input voltage (line to line)	200–240 V (±10%)	100–240 V

Specifications (continued)

	Three-phase line	Single-phase control
Input frequency	50/60 Hz	50/60 Hz
Maximum load current (per phase)	56 A	10 A

Branch circuit breaker specifications

Three-phase	3 poles, 63/70 A
Two-phase control	2 poles, 15/16/20 A

AC power cable specifications

	Three-phase line	Single-phase line
Configuration	4 wires, L1/L2/L3/PE	3 wires, L/N/PE
Wire	Strained Cu minimum, 10 mm ² (8 AWG)	Strained Cu minimum, 2.5 mm ² (16 AWG)
Terminals	Lines, ferrule terminals, PE, M8 ring terminal	Lines, ferrule terminals, PE, M4 ring terminal
External diameter range	22.0–33.0 mm	5.0–11.0 mm

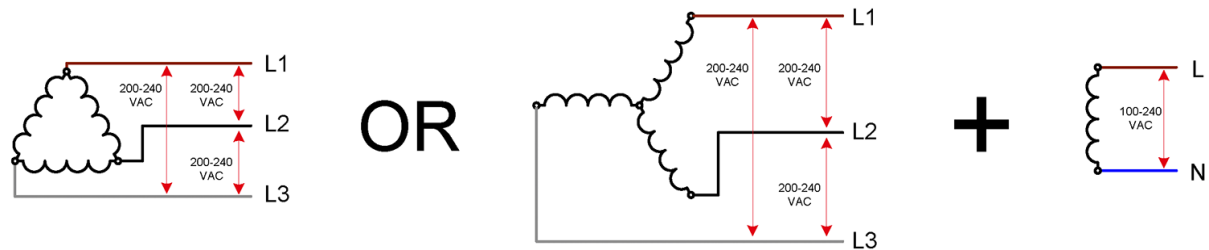

Circuit breakers (required)

The circuit breakers must meet the requirements of the printer and should be in accordance with the Electrical Code requirements of the local jurisdiction of the country where the equipment is installed.

The printer requires one or two branch circuit breakers, depending on the installation.

NOTE: The printer has built-in Residual-Current Circuit Breakers (RCCB), also known as Ground Fault Circuit Interrupters (GFCI), with 30 mA sensitivity. If local laws require an external RCCB or GFCI for earth fault protection, install a device with sensitivity of 100 mA or higher, with appropriate rated current for the supply configuration, and ensure that other protective devices for earth-fault protection upstream from the one supplying the printer are always greater than the one selected for the printer.

WARNING! The rated short-circuit-breaking capacity of the circuit breakers in the printer is 6 kA. This should be coordinated with the branch circuit breaker in PDU (Power Distribution Unit) if so required by the Electrical Code of the local jurisdiction.

WARNING! Ensure that the printer's built-in Residual-Current Circuit Breakers (RCCB) or Ground Fault Circuit Interrupters (GFCI) operate in the case of a current leakage fault to the product chassis, even when an isolation device (such as an isolating transformer) will be used to supply power to the printer.

Power cables

No power cable is provided with the printer. The cables that you use must meet the minimum specifications for the chosen configuration explained for each configuration.

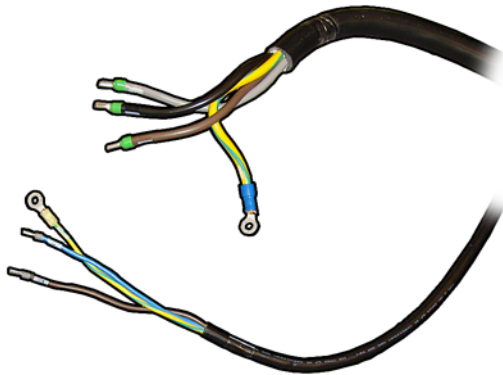

PE connections for mains power should be made through an M8 stub.

The power cable for PC power can be routed from above the right of the top cover; it can be routed from the ceiling.

Powerline disturbances

Reliable operation of your printer depends on the availability of relatively noise-free AC power.

- In order to ensure optimum performance and reliability, your printer should be protected from variations in line voltage, which are common to production printing environments. Lighting, line faults, or the power switching commonly found in machinery in factory environments can generate line transients that far exceed the peak value of the applied voltage. If not reduced, these micro-second pulses can disrupt system operation.
- If the power line supplying the installation site is a public low voltage line shared with other users, the power line impedance Z_{max} must be less than 70 m Ω , to comply with European standard EN/IEC 61000-3-11. If other users on the same power line report any flickering of incandescent light bulbs, contact your electricity supplier to verify that the power network has an impedance lower than the one specified above.
- This equipment complies with EN/IEC 61000-3-12 provided that the short-circuit power S_{sc} is greater than or equal to 2.5 MVA at the interface point between the user's supply and the public system. It is the responsibility of the installer or user of the equipment to ensure, by consultation with the distribution network operator if necessary, that the equipment is connected only to a supply with a short-circuit power S_{sc} greater than or equal to 2.5 MVA.
- It is recommended to include overvoltage (OVP) and transient protection on the power supply to the printer.
- All electrical noise generating equipment, like fans, fluorescent lighting, and air-conditioning systems, should be kept separate from the power source used for your printer.

Grounding

The printer must be connected to a good quality, dedicated ground line in order to avoid electrical risk. Note your obligation to comply with the National Electrotechnical Code (NEC) in the county of installation.

The following grounding tasks must be fulfilled to meet the site preparation requirements:

- Grounding wires should be insulated and at least equal in size to the phase conductors.

- Ground impedance should be less than 0.5 Ω .
- A single point and dedicated ground should be installed.
- Power stabilizer equipment should be supplied by three uninterrupted phase wires and one uninterrupted copper ground wire from the main building service panel. These should run in the same conduit and should be at least equal in size to the phase wires.

Air supply requirements (pneumatic spindle)

The pneumatic spindle requires an air compressor or pressurized air line that must be provided by the customer.

 **TIP:** HP recommends that you use an air compressor with a pressure gauge that measures in bars.

Air supply specifications

	Specification
Air pressure	5.5 bar (80 psi) (required)
Minimum airflow	30 liters/minute (1.06 cubic feet/minute)
Lubricator (not required)	Not recommended
Air filter (recommended)	Recommendation: 5 μm , auto-drain, 99.97% coalescing efficiency
Regulator (required)	Regulator with pressure gauge

Pneumatic connector

The printer comes with an air gun that you must attach to your air supply. In order to connect your air supply to the air gun, you must meet the following requirements:

- 6.35 mm (0.25 in) female connector, BSP or NPT thread
- PTFE tape to secure the connection and prevent air leaks

 **CAUTION:** Take care when using the air gun. When used for cleaning purposes, make sure to use it according to the local regulations since additional safety provisions may apply.

Room requirements

The room in which the printer is installed needs to be suitable in various ways.

Temperature and humidity

The temperature, humidity, and temperature gradient during operation and during storage must be kept within the standard ranges to ensure the correct operation of the printer.

Failure to keep these environmental conditions within the standard ranges may cause print-quality problems or damage sensitive electronic components.

Printer environmental specifications

	Temperature range	Relative humidity range	Temperature gradient
Operating for optimal print quality	20 to 25°C (68 to 77°F)	30 to 60%	10°C/h (50°F/h) or less
Operating for standard printing	15 to 30°C	20 to 70%	10°C/h (50°F/h) or less
Not operating (in transport or storage), ink in tubes	5 to 55°C (41 to 131°F)	90% at 55°C (131°F)	10°C/h (50°F/h) or less
Not operating (in transport or storage), no ink in tubes	-25 to 55°C (-13 to 131°F)	90% at 55°C (131°F)	10°C/h (50°F/h) or less

Maximum operating altitude: 3000 m (10000 ft)

In addition to controlling the temperature, humidity, and temperature gradient, there are other environmental conditions that must be met during site preparation.

- Do not install the printer where it will be exposed to direct sunlight or a strong light source.
- Do not install the printer in a dusty environment. Remove any accumulated dust before moving the printer into the area.

Ventilation

Ensure that the room in which the system is installed meets local environmental, health, and safety (EHS) guidelines and regulations.

Adequate ventilation needs to be provided to ensure that potential airborne exposure is adequately controlled according to Safety Data Sheets. Consult the Safety Data Sheets available at <http://www.hp.com/go/msds> to identify chemical ingredients of your ink consumables.

Airborne materials can be readily identified and quantified by using established indoor air quality testing protocols. HP performs these assessments during the development phase for all products.

HP testing shows that, during printer operation, the concentrations of airborne contaminants measured in the workspace are consistently well below key occupational exposure limits. This observation is based on exposure assessments that model very active productivity at customer facilities. Customers should recognize that actual levels in their facilities are dependent on workspace variables they control such as room size, ventilation performance, and duration of equipment use.

HP's assessment, based on the available scientific information, concluded that airborne materials are not expected to present a health hazard as long as you provide a minimum of 10 ACH (air changes per hour) of fresh air ventilation and a minimum room volume of 140 m³ (4944 ft³).

These specifications are valid for the following conditions: one HP printer printing a black area-fill plot at 100 m²/h (1076 ft²/h), 3 passes, 90% of ink, assuming 8 hours of printing exposure time a day. If there is more equipment in the room, or different conditions, the ventilation rate should be recalculated accordingly.

In addition to the workspace benefit provided by general room ventilation, intensive use of this printer system may require the use of localized ventilation in order to provide a more comfortable working environment. See [Local exhaust on page 13](#) for more information.

Local exhaust

Intensive use of this printer system may necessitate the use of localized ventilation in order to provide a more comfortable working environment.

The installation of a localized exhaust system for a printer enables the capture of airborne contaminants and heat near their source of generation, and subsequently removes them efficiently from the building through contained and relatively low-volume air flow.

A workspace health and safety professional can provide guidance on the design and use of this auxiliary ventilation equipment.

Recommended airflow: 400 to 500 m³/h (14126 to 17657 ft³/h)

Recommended pressure: -10 to -45 Pa

Airflow and pressure should be measured at the connection between the local exhaust and the printer.

HP recommends not using ABS, PC, steel, or EG steel materials for the local exhaust installation. PVC, SS, PP, or aluminum are better options.

Air conditioning

In addition to fresh-air ventilation, consider the use of air conditioning to maintain appropriate working conditions and avoid health hazards.

You should aim to provide the working conditions specified in this guide (see [Temperature and humidity on page 12](#)), to avoid operator discomfort and equipment malfunction.

Air conditioning in the work area should take into account that the equipment produces heat. Typically, the printer's power dissipation is 11 kW (37.5kBTU/h).

Air conditioning should meet local environmental, health, and safety (EHS) guidelines and regulations.

 **NOTE:** The air conditioning units should not blow air directly onto the equipment.

Load bearing

The load-bearing characteristics of the floor in the print production area should be sufficient to withstand the weight of your printer. To calculate the load-bearing characteristics of the print production floor, consult a structural engineer.

Printer weight with packaging	1857.5 kg (4095 lb)
Printer weight without substrate	1303 kg (2872.6 lb)
Load on each foot	650 kg (1433 lb)

Your printer has four wheels used to move the printer and three feet that must be lowered to touch the ground and support the printer. The following illustration shows where the feet and wheels touch the ground, in case you need extra reinforcements.

Printer feet



Printer dimensions

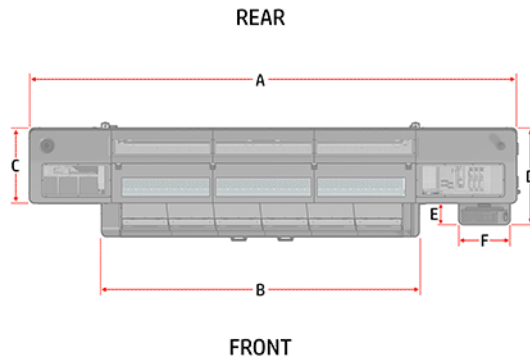

In the table below, the number or letter in the left column corresponds to the diagram above.

A	5.7 m (224.4 in)
B	3.73 m (146.8 in)
C	1.12 m (44.1 in)
D	1.37 m (53.9 in)
E	0.25 m (9.8 in)
F	0.60 m (23.6 in)

Floor surface

The floor surface should have various specific characteristics.

- Horizontal surface
- Solid, smooth, and level
- No holes or indentations
- Static-free surface (no carpet)
- Easy to clean
- Durable

- Free from strong vibrations
- Concrete

Lighting

Whenever your printer is in operation, the print production area should be well lit to provide the operator with optimal conditions for checking the color and alignment during print production.

If there is not enough natural light, artificial lighting will be required.

Designing the print production area

The print production area is where the printer is installed.

Fire-fighting equipment

You should provide two fire extinguishers for the site. Make sure the extinguishers are placed where they are easily accessible in case of fire.

- A fire extinguisher certified for electrical fires should be in the print production area.
- A fire extinguisher should be placed in the substrate storage area, due to the large amount of solid combustibles (substrates).

Emergency exits and first aid stations should also be considered.

Optimal room layout

The printer should have enough space around it to permit normal operations.

You need enough space to perform the following tasks:

- Print
- Use the HP Internal Print Server
- Replace a substrate roll
- Service the printer or replace printer components
- Ensure the printer is well ventilated

Your printer has the following dimensions:

Weight	1300 kg (2866 lb)
Width	5.72 m (225.2 in)
Depth	1.37 m (53.9 in)
Height	1.53 m (60.2 in)

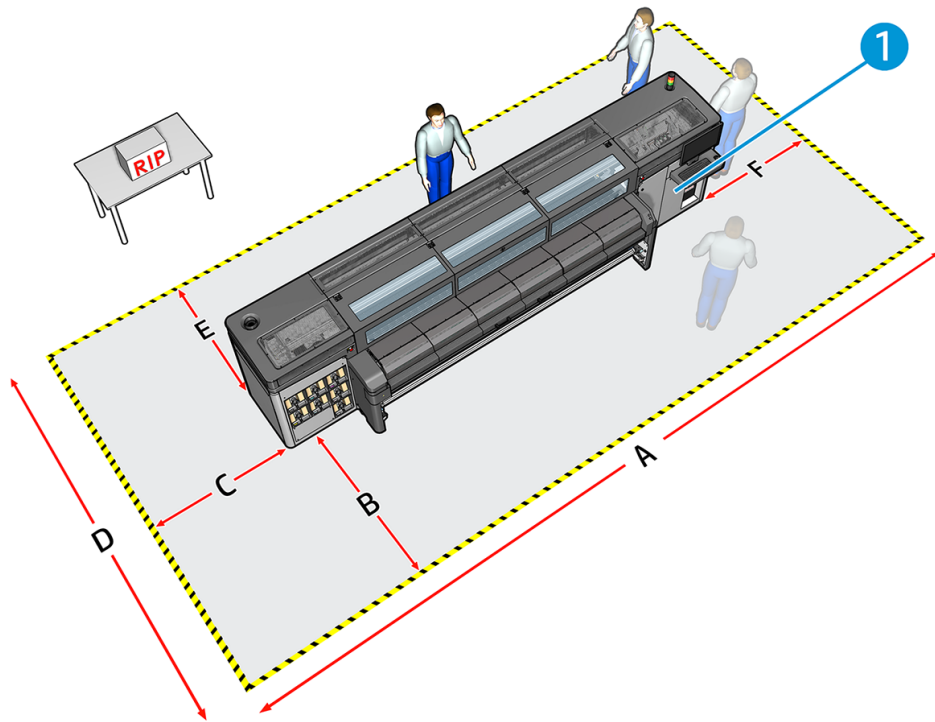

1. Electrical connection.

Measurements within the room

Measurement	
A	8.725 m (28 ft 7.5 in)
B	1.5 m (4 ft 11 in)
C	1.5 m (4 ft 11 in)
D	4.27 m (14 ft 0.1 in)
E	1.5 m (4 ft 11 in)
F	1.5 m (4 ft 11 in)

The ceiling of the room should be at a minimum height of 3 m (9 ft 9 in) above the floor.

TIP: If you want to load rolls of 3.2 m (126 in) width without removing the spindle from the support near the built-in computer, the distance C should be 2.4 m (7 ft 10.5 in) to provide enough space for the loading process.

WARNING! The zone surrounding the printer should be considered a restricted access area and signaled accordingly. Only trained personnel should be operating within this area.

Storage area for materials

When planning a storage area for materials used with the printer, thought should not only be given to safety and convenience, but also to the fact that if inks and substrates are not stored in the appropriate temperature and humidity conditions, print results may be adversely affected.

The storage area should be of sufficient size to accommodate adequate stocks of substrate rolls and inks. The storage area should be located near the print production area to minimize the lifting and maneuvering of heavy materials.

The storage area should have a covered roof. It should be dry, well ventilated, and able to provide protection from direct light. It is important that temperature and humidity are maintained within values specified for each substrate type.

 **NOTE:** Allow enough (environmentally controlled) space to store the printheads. This is indicated by the directional arrows on the printhead boxes.

Storage conditions for substrate rolls

Keep substrate rolls in their sealed wrapping material while they are placed in storage.

Store substrate rolls vertically to avoid the migration of plasticizers in some materials.

Move substrates from the storage area to the print production area at least 24 hours before use, so that they can reach the required moistness and operating temperature.

 **NOTE:** HP substrate rolls have a 12 month warranty when the substrate rolls are stored under optimal conditions. The warranty term varies depending upon the material and the manufacturer.

Computer and networking requirements

The printer requires hardware and software to certain specifications, some provided by HP and some by the customer.

Network functionality requires an **Outbound** connection to all the following addresses.

Remote domain	Protocol and port
hp.com	https 443
heleni.me	https 443

 **NOTE:** If needed, please instruct the customer IT to create routing rules that route around the proxy for these addresses.

A minimum upload speed of 5 Mb/s is required.

HP-provided components

- HP Internal Print Server
 - PC and power cord
 - PC LAN card connections: Two Ethernet ports, one for the e-box LAN cable to connect the printer to the PC, and the other to connect to the network
 - Two monitor and power cords
 - Windows 10 embedded operating system
 - HP Internal Print Server software

Customer-provided components

- Ethernet LAN (minimum 1 Gb/s) connection
- RIP station and software
- CAT-6 LAN cable long enough to connect the printer to the network

RIP requirements

There are two RIPs offered by HP that may be used with the printer.

- HP Large Format Onyx Thrive RIP, from version 21.1 onwards: product number D9Z41B
- HP Large Format Caldera Grand RIP, from version 15 onwards: product number L5E74C

The software and hardware requirements of these RIPs are as follows.

HP Large Format Onyx Thrive RIP

- Main workstation requirements:
 - Operating system: Microsoft Windows 7 Professional, Enterprise, or Ultimate; Windows 8.1 Professional or Enterprise; or Windows 10 Professional or Enterprise

 **NOTE:** 32-bit operating systems have a hardware limit of 4 GB of RAM. HP recommends using 64-bit operating systems for high-volume workflows.

- Processor: Intel Core i7 or equivalent, minimum 6 available cores, recommended 12 or more cores
- RAM: 4 GB per RIP and core (for example, one RIP and 6 cores: 24 GB)
- Hard disk drive or (recommended) solid-state drive: 250 GB
- Network connectivity: Gigabit Ethernet for TCP/IP printers

 **NOTE:** Firewall and antivirus must be disabled or configured to allow ONYX applications and printer ports (80 TCP, 8085, 8086, 8080, 3389, and 445 TCP\UDP). There may be other ports needed, see device manufacturer's documentation for details.

- Monitor: 1280 × 1024 pixels, 16-bit color
- USB port for security key

- Distributed workstation requirements:
 - Operating system: Microsoft Windows 7 Professional, Enterprise, or Ultimate; Windows 8.1 Professional or Enterprise; or Windows 10 Professional or Enterprise

 **NOTE:** 32-bit operating systems have a hardware limit of 4 GB of RAM. HP recommends using 64-bit operating systems for high-volume workflows.

- Processor: Intel Core i7 or equivalent
- RAM: 4 GB/processing core
- Hard disk drive or (recommended) solid-state drive: 250 GB free

- Network connectivity: Gigabit Ethernet for TCP/IP printers



NOTE: Firewall and antivirus must be disabled or configured to allow ONYX applications and printer ports (80 TCP, 8085, 8086, 8080, 3389, and 445 TCP\UDP). There may be other ports needed, see device manufacturer's documentation for details.

For the latest details of Onyx configuration, see <http://www.onyxqfx.com/system-specifications/>.

HP Large Format Caldera Grand RIP (minimum configuration)

- Linux:
 - Operating system: Debian Mate recommended, desktop environment 10 (Mate desktop environment 8.6, 8.8, 9.5), which should be downloaded from the Caldera website; or Caldera Debian 2 (APPE3, not APPE4)
 - Processor: Intel Core i3, i5, or i7
 - RAM: 4 GB or 8 GB (recommended). Minimum 1 GB per core, recommended at least 2 GB per core
 - Hard disk drive or (recommended) solid-state drive: 250 GB
 - Monitor/video card: 1280 × 1024 minimum resolution (NVMe SSD not yet supported)
- Mac:
 - Operating system: macOS 10.9+ (check compatibility at <http://www.caldera.com/support/os-compatibilities/>)
 - Hardware: Intel Core i3-, i5-, or i7-based Mac mini, iMac, or Mac Pro. Recent MacBooks can be used for demonstration but are not supported by Caldera in production. PPC-based hardware (G5, G4, ...) is not supported.
 - 4 GB or more. Minimum 1 GB per core, recommended at least 2 GB per core.
 - Hard disk drive or (recommended) solid-state drive: 250 GB
 - Monitor: 1280 × 1024 minimum resolution

For the latest details of Caldera configuration, see:

- <http://www.caldera.com/support/minimal-requirements/>
- <http://www.caldera.com/product/grandrip/>

External color profiling

In order to build color profiles for your printer, an external color sensor is needed. Make sure to choose an external spectrophotometer that is compatible with your RIP.

During the installation training, it is the customer's responsibility to have a RIP specialist available to create color profiles.

3 Shipment arrival preparation

Prepare in advance to receive the printer and transport it to the installation site.

Unloading area

You must designate a suitable unloading area that will be easily accessible to the delivery truck.

It should have sufficient space to unload the large package in which your printer is shipped. When planning this area, consider the following:

- Height and width of entrance to unloading area
- Ramps used to access the unloading area
- Height and size of unloading dock (if applicable)

Route from unloading site to installation site

The route between the unloading area of the printer and the installation site, including any corridors and doorways through which the printer must be transported, is important to proper site preparation and must be planned before the arrival of the printer. This pathway must be clear when the printer arrives.

Regarding ground-floor room access, transport of the bulky printer components requires:

Doorway, ceiling, and corridor specifications

	Printer	Package
Minimum doorway width	1.55 m (61 in)	1.9 m (74.8 in)
Minimum ceiling height	1.85 m (72.9 in)	2 m (78.8 in)
Minimum corridor width	1.55 m (61 in)	1.9 m (74.8 in)
Minimum corridor width for a 90° turn	3.9 m (154 in)	3.9 m (154 in)

⚠ WARNING! After being removed from the package, the printer can be moved up or down a ramp of no more than 3% inclination.

💡 TIP: Decide when you will remove the printer from the package. It is recommended that the shipping package be unpacked as close as possible to the printer's final destination. Usually, the printer is removed from the package before moving it to the installation site.

Disassembling the package requires an electric screwdriver that must be plugged into a power outlet, so make sure that a power outlet is available near the site where you plan to disassemble the package.

Shipment items

All printer components will arrive in a single package.

Dimensions and weight of the packaged printer

	Width	Depth	Height	Weight
Package (printer inside)	5.86 m (231 in)	1.81 m (71.3 in)	1.91 m (75.2 in)	2000 kg (4409 lb)
Printer	5.72 m (225.2 in)	1.37 m (53.9 in)	1,67 m/1,53 m, no beacon (66 in/60.2 in, no beacon)	1303 kg (2872.6 lb)

Tools and manpower required for installation

The installation process requires four capable people if ramps are used. If a forklift is used, only two people are needed, usually the installer and the operator. Additionally, a certified electrician is required to configure the electrical system.

Before delivery, check with the installation specialist whether you need to provide any tools.

Moving equipment

You may need to provide additional equipment to move the printer to the installation site.

IMPORTANT: If you move the printer with its packaging using a crane, position the slings as shown below.

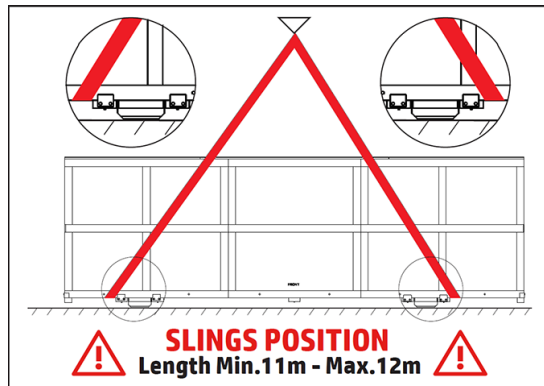

Ground-floor installation

HP strongly recommends lowering the printer with the ramps as indicated in the installation guide. In exceptional cases, where ramps cannot be used due to a physical barrier, follow the alternative instructions indicated carefully.

CAUTION: Unloading and moving the printer and all system components is the customer's responsibility and not HP's. Failure to provide the required moving and lifting apparatus could result in personal injury or damage to the printer during installation.

Lower the printer with ramps

In some cases, extra moving and lifting equipment may be required.

- Minimum room space to lower: 4.5 m beside the package, 6.4 m total
- Minimum manpower: 4 people
- Flat floor or maximum 3% inclination

If any specification cannot be met, use a forklift to lower the printer.

Lower the printer with forklift

The use of specialist moving and lifting equipment is required during the unloading, unpacking, and installation of your printer.

The forklift accessory is needed for this operation; it can be ordered as a service kit (K4T88-67290).

Advanced booking for the services of a machinery-moving contractor/rigger must be made. It is important to confirm that the hired moving specialist and moving equipment will be available when the printer is delivered.

The following equipment is recommended:

- Wide, heavy-duty forklift (required)

Forklift specifications

	Weight capacity	Minimum fork length	Inner distance between forks
Forklift	3500 kg (7716 lb)	2 m (79 in) for packaged printer 1.5 m (59 in) for printer only	1.3 m (51 in)

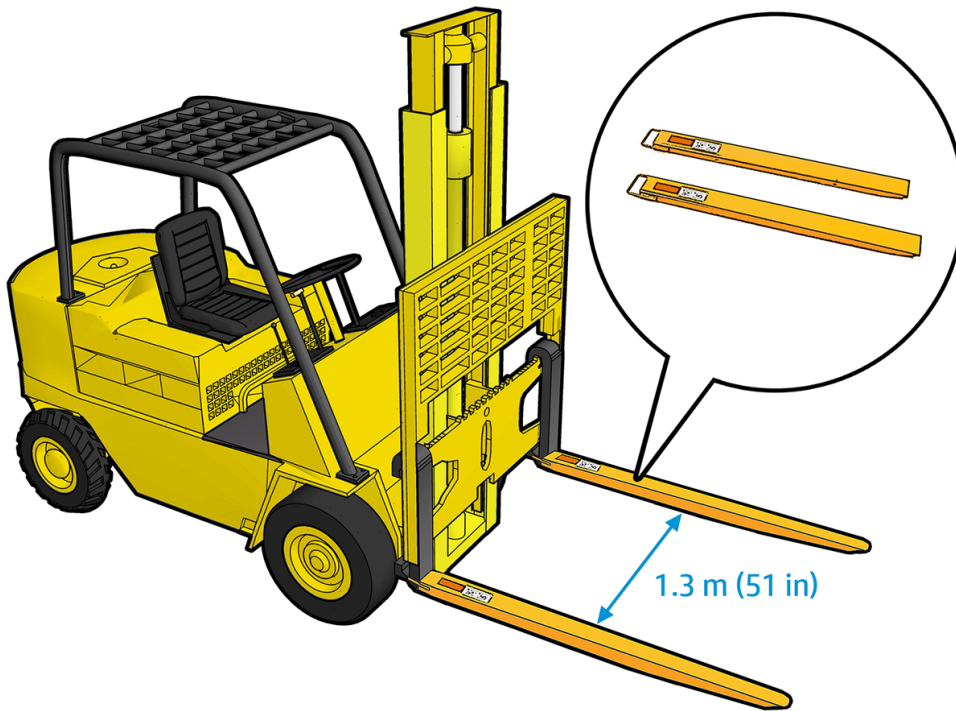

- Two skates to move the package (optional)

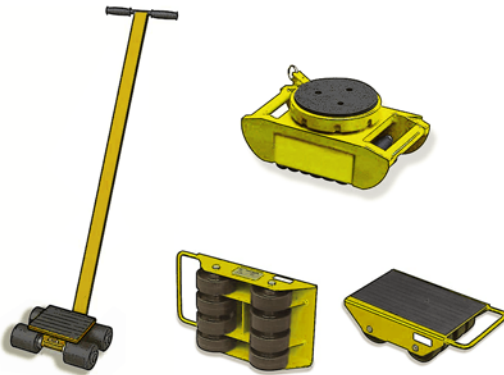

- Electric pallet jack (optional)

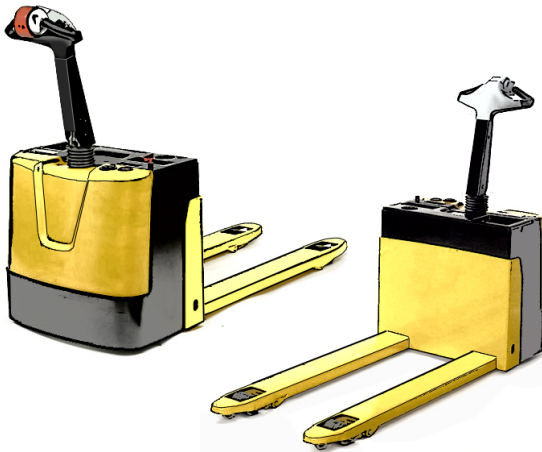

- Manual pallet jack (optional)

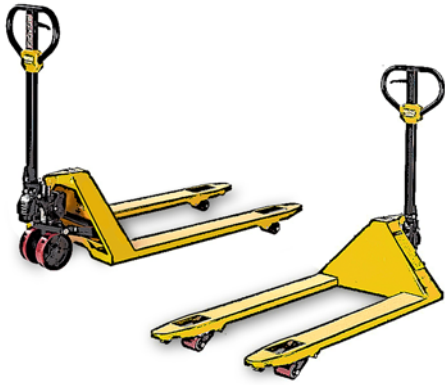

Above-ground-floor installation

Above-ground-floor installation requires a crane and special lifting gear in addition to the standard moving equipment.

At some installation sites, it may be necessary to remove the packaging before lifting the printer with the crane.

-
- ⚠ CAUTION:** Unloading and moving the printer and all system components is the responsibility of the customer and not HP. Failure to provide the required moving and lifting equipment could result in personal injury or damage the printer during installation.
-

Crane attachment to lift the printer with a spreader beam

When you lift the printer with a spreader beam, the lifting bars and spreader beam must be long enough so that the lift cables do not touch the printer.

NOTICE: The forklift accessory (K4T88-67290) is needed for this operation.

- ⚠ CAUTION:** When lifting the printer with a crane, extra caution should be taken to ensure that the cables do not apply pressure to the carriage beam or any other printer component.
-

How to lift the printer with a spreader beam

1 → 1 m (39 in)

2 A 1 x 15'2 m (1 x 598 in)
B 2 x 7,6 m (2 x 299 in)

3 → 0,25 m (10 in)

4 → 1,59 m (63 in)

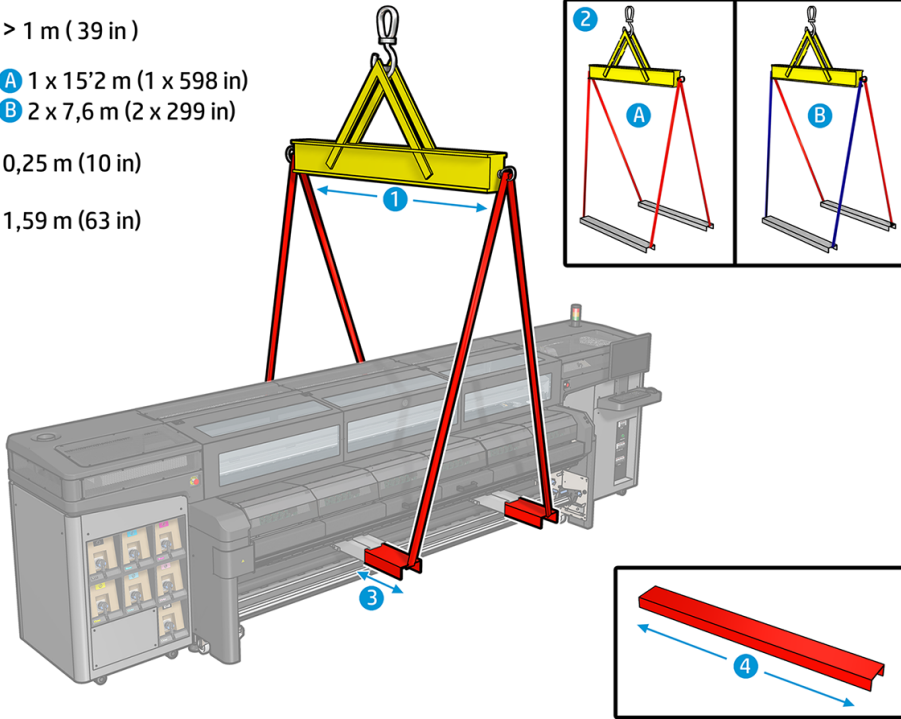

Waste disposal

Printer packaging can be reused for moving the printer at a later date.

Alternatively, the packaging material that comes with the printer can be disposed of. Most of the waste will be wood materials. Consult with your local authorities to determine the correct manner in which to dispose of it.

HP recommends keeping the internal printer retainers (small parts), in case the printer needs to be moved later.

4 Site preparation checklist

The site preparation checklist must be completed before delivery of the product. It is normally completed online.

How to create a Site Preparation

To create the Site preparation for the customer you can do it through the Service Center for channel Desktop App (SC4CH) or with Service Center for Channel Mobile App.

 **NOTE:** We recommend to do it through SC4CH Mobile App.

How to create Site preparation in SC4CH Mobile App

First you need to download and install the app on your smartphone.

PrintOS for Channel mobile app



Monitor your site's performance,
at the palm of your hand



1. Go to Installed base tab 
2. Click on Site preparation tab

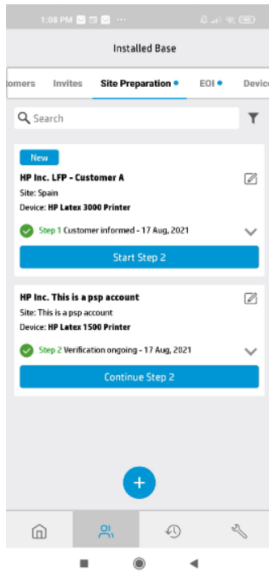

3. Add new Site prep 
4. Fill customer info

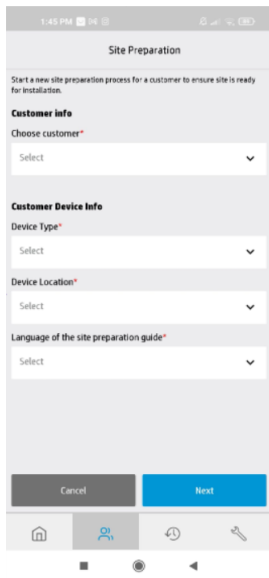

5. Verify information

The screenshot shows a mobile app interface titled "Site Preparation". It contains a form with the following information:

Customer info

- Customer: HP Inc. LFP - Customer A
- First name: test
- Last name: test
- Email: lolaffreshp@ mail.com

Customer Device Info

- Device Type: HP Latex 3200 Printer
- Device Location: Spain
- Language: Spanish

At the bottom, there are "Back" and "Send" buttons. The app's navigation bar includes icons for home, user profile, refresh, and settings.

6. Customer will receive Email

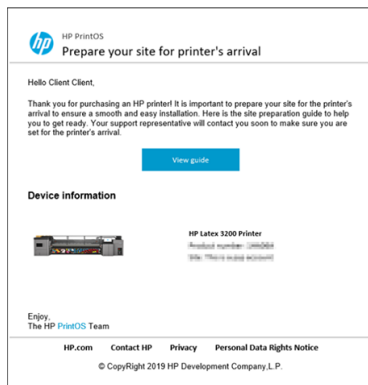

7. To start with the Site preparation checklist go to section [SC4CH Mobile app on page 31](#).

How to create Site preparation in SC4CH Desktop App

1. Go to Installed base tab

The screenshot shows the "Installed Base" tab in the SC4CH Desktop App. The table below summarizes the data shown in the interface:

VP	CUSTOMER	SITE PREPARATIONS ON-GOING	PENDING	ACTION REQUIRED	ACTIVE CASES	DEVICE UNDER COVERAGE	INVITATION STATUS
	HP Inc. LFP - Customer A	-	-	-	2	15	Connected 20 Apr 2017
	HP Inc. LFP - Customer B	-	-	-	-	17	Connected 28 Apr 2017
	HP Inc. LFP - Customer M	-	-	-	3	15	Connected 02 May 2018
	HP Inc. This is a prep account	1	-	-	-	2	Connected 28 Apr 2021

2. Click New printer installation

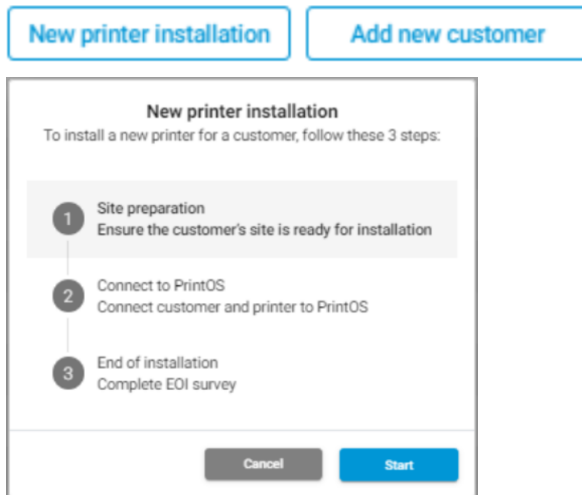

The dialog box is titled "New printer installation" and contains two buttons at the top: "New printer installation" and "Add new customer". Below the buttons, the text reads: "To install a new printer for a customer, follow these 3 steps:". A vertical list of three steps follows: 1. Site preparation (Ensure the customer's site is ready for installation), 2. Connect to PrintOS (Connect customer and printer to PrintOS), and 3. End of installation (Complete EOI survey). At the bottom, there are "Cancel" and "Start" buttons.

3. Fill customer info

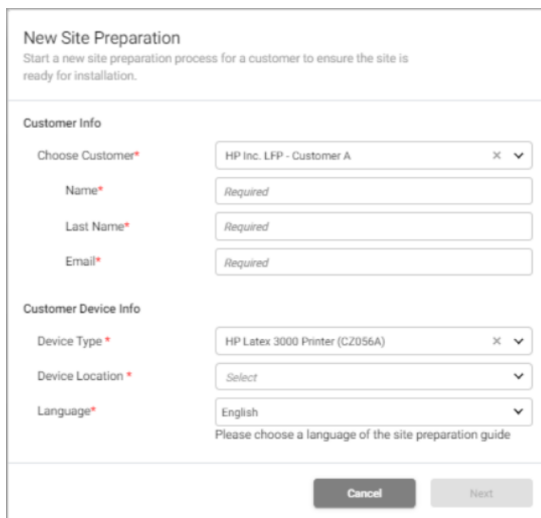

The form is titled "New Site Preparation" and contains the following fields: "Choose Customer*" (dropdown menu with "HP Inc. LFP - Customer A"), "Name*" (text input with "Required" placeholder), "Last Name*" (text input with "Required" placeholder), "Email*" (text input with "Required" placeholder), "Device Type*" (dropdown menu with "HP Latex 3000 Printer (CZ056A)"), "Device Location*" (dropdown menu with "Select" placeholder), and "Language*" (dropdown menu with "English" and a note "Please choose a language of the site preparation guide"). At the bottom, there are "Cancel" and "Next" buttons.

4. Verify information

Verify Information to start Site Preparation

Customer Info

Choose Customer	HP Inc. LFP - Customer A
Name	test
Last Name	test
Email	lolafloreshp@hp.com

Customer Device Info

Device Type	HP Latex 3000 Printer (CZ056A)
Device Location	Spain - null, null, null
Language	English

Verify the information above to begin the **Site Preparation**. The site preparation guide will be send to the customer.

To do Site Preparation you will need an HP PrintOS Service Center mobile app. Download it on [Apple Store](#) or [Google Play](#)

5. Now you can:

- Complete the site preparation on SC4CH Mobile App

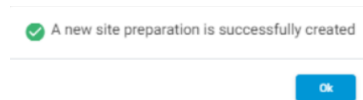

- Or Complete it manually and upload in SC4CH

Fill the Site preparation

You can fill the site preparation manually, but we recommend to completed it with SC4CH Mobile App as will be integrated with the installation process through the app.

Manually

If for any reason customer cannot fill the checklist through SC4CH Mobile app, the customer can fill it manually as received the Site preparation through email using the Check boxes from the Site preparation PDF. Always it's a good option to help customer to fulfil this Checklist.

Then you need to upload the document into SC4CH. To know how to do it do to section [How to upload Site preparation in SC4CH Mobile App on page 40](#).

SC4CH Mobile app

1. Go to Site preparation tab and click **Continue step 2**.

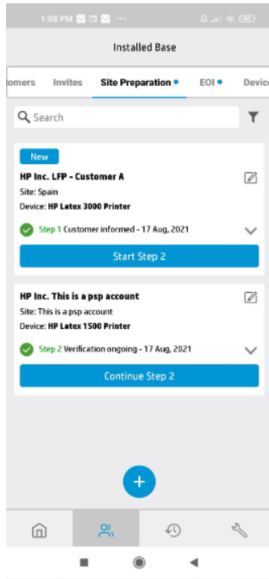

2. Add Address information

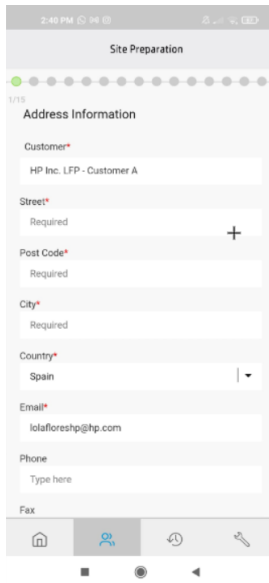

3. Fill customer information

The screenshot shows the 'Customer information' form in the 'Site Preparation' app. The app is running on a mobile device at 2:46 PM. The form is titled 'Customer information' and is for a 'System Administrator'. It contains the following fields:

- Full name***: A text input field containing 'test test'.
- Email***: A text input field containing 'lolafloreshp@hp.com'.
- Phone**: A text input field with the placeholder 'Type here'.
- Operator to be trained on printer use and maintenance**: A dropdown menu with the value '1' selected.
- Operator 1**: A section with three required fields: 'Full name*', 'Email*', and 'Phone', each with a 'Required' label and a 'Type here' placeholder.

The bottom navigation bar shows icons for Home, Profile, Refresh, and Settings. The progress indicator at the top shows 2/15 steps completed.

4. Fill Field Engineer information

The screenshot shows the 'Field Engineer Information' form in the 'Site Preparation' app. The app is running on a mobile device at 2:47 PM. The form is titled 'Field Engineer Information' and is for a 'Company engineer or technician (Myself)'. It contains the following fields:

- Full name***: A text input field with a 'Required' label.
- Email***: A text input field with a 'Required' label.
- Phone***: A text input field with a 'Required' label.

Below the form are three buttons: 'Previous', 'Next', and 'Save and continue later'. The bottom navigation bar shows icons for Home, Profile, Refresh, and Settings. The progress indicator at the top shows 3/15 steps completed.

5. Printer planning installation



6. Fill General access&equipment unloading

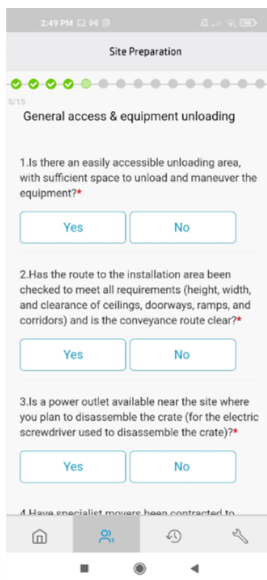

7. Fill room layout & flooring

The screenshot shows the 'Site Preparation' app interface. At the top, the time is 2:50 PM. Below the title 'Site Preparation', there is a progress indicator with 15 steps, where the first 6 are green and the rest are grey. The current step is 'Room layout and flooring' (6/15). The section contains four questions, each with 'Yes' and 'No' buttons:

1. Is there sufficient space around the equipment?
2. Has all room construction and painting been completed?
3. Does the floor load-bearing capacity meet the specifications in the site preparation guide?
4. Does the floor surface meet the specifications in the site preparation guide? If special reinforcements are necessary, are they completed?

At the bottom, there is a navigation bar with icons for Home, Profile, Refresh, and Search.

8. Fill Safety requirements

The screenshot shows the 'Site Preparation' app interface. At the top, the time is 2:52 PM. Below the title 'Site Preparation', there is a progress indicator with 15 steps, where the first 7 are green and the rest are grey. The current step is 'Safety requirements' (7/15). The section contains three questions, each with 'Yes' and 'No' buttons:

1. Is there an emergency exit in the print production area, with easy access and free from any obstruction?
2. Have the two fire extinguishers been fitted in the prescribed locations in the print production and storage areas? Is the print production fire extinguisher rated for electrical fire?
3. Have strategic locations been allocated for the fixture and display of the appropriate safety warning signs?

At the bottom, there is a navigation bar with icons for Home, Profile, Refresh, and Search.

9. Fill Electrical installation

2:53 PM 94%

Site Preparation

8/15

Electrical installation

1. Has the site been prepared for the chosen power option? *

Configuration 1 branch circuit breaker:

4 poles, 40/50 A

Configuration 2 branch circuit breaker:

3 poles, 63/70 A

Configuration 3 branch circuit breaker:

Three-phase: 4 poles, 40/50 A

Two-phase control: 2 poles, 15/16/20 A

Configuration 4 branch circuit breaker:

Three-phase: 3 poles, 63/70 A

Two-phase control: 2 poles, 15/16/20 A

Configuration 5 branch circuit breaker:

2 poles, 90 A

Configuration 6 branch circuit breaker:

Navigation icons: Home, Profile, Back, Search

10. Fill electrical configuration

2:55 PM 94%

Site Preparation

9/15

Electrical configuration

1. Do you need an Uninterrupted Power Supply (UPS)? If so, is it correctly installed?

2. No power cords are supplied with the printer; does the electrician understand that power cord(s) must be provided according to printer specifications and local laws? +

3. If local regulations specify that you must use electrical plugs to connect the printer to the power supply, does the electrician have the required plugs ready for installation?

Navigation icons: Home, Profile, Back, Search

11. Fill Networking requirements

2:56 PM 100% 4G

Site Preparation

10/15

Networking requirements

1. Have network connections been supplied?

Yes No

2. Do you have a LAN cable long enough to connect the printer to the network?

Yes No

3. Do you have an Internet connection?

Yes No

Previous Next

Save and continue later

12. Fill Equipment preparation

2:58 PM 100% 4G

Site Preparation

11/15

Equipment preparation

1. Is the air compressor or pressurized air line ready for the day installation?

Yes No

2. Have the correct supplies been ordered for deliver on or before the date of the printer's installation?

Minimum requirements: 1 set of ink cartridges

Recommended : 1 set of ink cartridges, an extra set of ink cartridges, and the correct substrate for training purposes.

Yes No

Previous Next

Save and continue later

13. Fill RIP requirements

The screenshot shows the 'RIP requirements' section of a mobile application. At the top, there is a progress bar with 12 green checkmarks, indicating that previous steps have been completed. Below the progress bar, the text '12/15' is visible. The section title is 'RIP requirements'. There are three numbered questions, each followed by 'Yes' and 'No' buttons:

1. Has the HP Scitex ONYX Thrive RIP v12.2 (or later) software (D9Z41A) been ordered, and is the computer to be used available with the required specifications ?
2. Has the HP Scitex Caldera Grand RIP v11.2 (or later) software (L5E74A) been ordered, and is the computer to be used available with the required specifications ?
3. If neither of the HP Scitex RIPs is to be used, is there a computer available with a RIP application installed that supports the printer?

At the bottom of the screen, there is a navigation bar with icons for home, user profile, refresh, and search. The Android navigation bar is also visible at the very bottom.

14. Fill Environmental Requirements

The screenshot shows the 'Environmental requirements' section of a mobile application. At the top, there is a progress bar with 12 green checkmarks, indicating that previous steps have been completed. Below the progress bar, the text '13/15' is visible. The section title is 'Environmental requirements'. There are four numbered questions, each followed by 'Yes' and 'No' buttons:

1. Have the temperature and humidity requirements been satisfactorily met in the print production area, and is there adequate ventilation or air conditioning ?
2. Have the temperature and humidity requirements been satisfactorily met in the storage area ?
3. Is the print production area free from dirt and dust?
4. Does the print production area have sufficient insulation?

At the bottom of the screen, there is a navigation bar with icons for home, user profile, refresh, and search. The Android navigation bar is also visible at the very bottom.

15. Completion Level Review

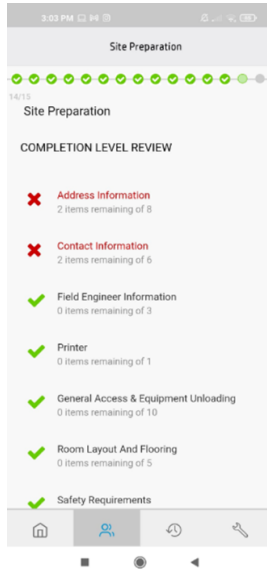

16. Customer signs



17. Checklist is submitted! Click Done to finish.

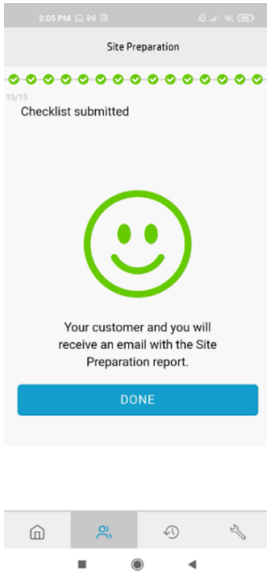

18. Now once the printer arrives to the site you can continue from this step to the installation.

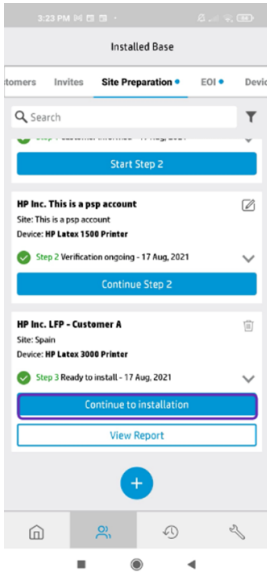

How to upload Site preparation in SC4CH Mobile App

If the Site Preparation is completed Manually

If the site preparation was completed manually ask to the customer to send the fulfilled pdf document to you.

Then you can upload the PDF document to the printer card through Service Center for Channel Mobile app following the next steps:

1. Go to PrintOS Service Center for Channel **Home tab** and **Select the customer**

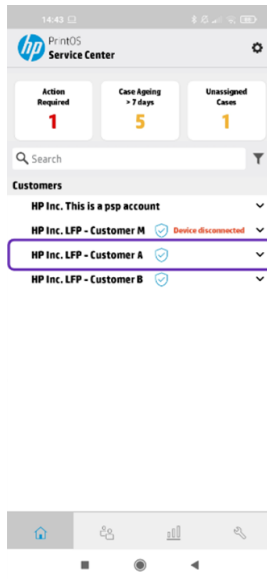

2. Click on the **printer**

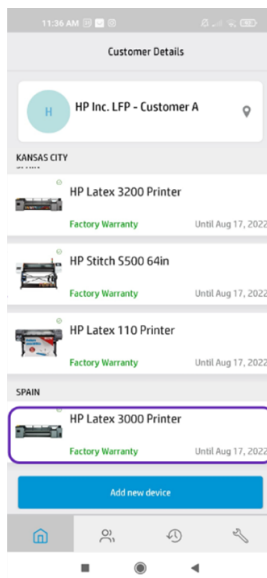

3. Click on **Printer Card info**

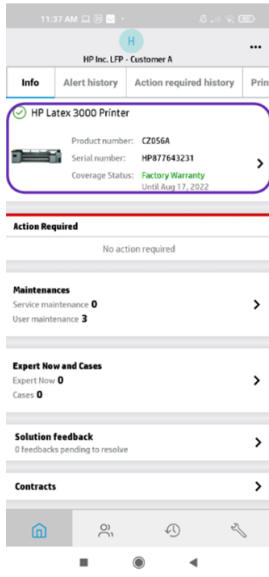

4. Click on **UPLOAD Site preparation report**

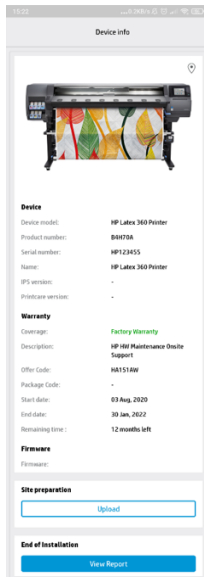

If the Site Preparation is completed in PrintOS

If the site preparation is completed Through SC4CH Mobile App, will be uploaded automatically in PrintOS.

Once you have submitted the site preparation for your printer **through** Service Center for Channel mobile app, then you can start the installation of the printer. But before **you need to invite the customer to PrintOS** and create an account.

1. Go to your **PrintOS Service Center for Channel mobile app**
2. Go to **Site Preparation** tab and find your printer to continue to installation
3. Click on **Continue to installation**

4. You will be redirected to **Add customer & device** panel

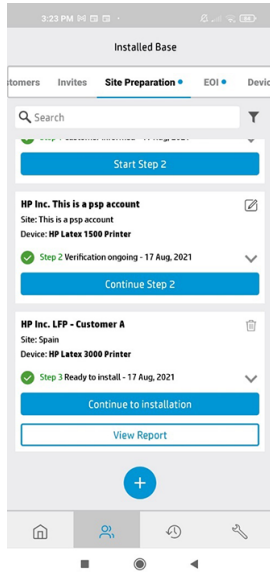

5 Complete the checklist on paper

Print the following pages and complete the address information, contact information, and checklist.

If a checklist item cannot be completed or is unnecessary, add a short explanation under 'Comments'. Once you have completed the checklist, sign it and send it to your reseller or HP sales representative a minimum of two weeks before the delivery date.



NOTE: Some checklist items are marked '(Required)', which means that you cannot proceed with installation until you have checked the 'Yes' box.

Checklist

When you sign this document, you are confirming that the site has been prepared according to the specifications provided in the site preparation guide, that all checklist items have been completed, and that the site is prepared and ready for delivery and installation.

Address information

Company name	Postal code
Street address	Telephone
City	Fax
Country	E-mail

Contact persons

Name	Telephone	Email
Company engineer or technician		
System administrator		
Operators to be trained on printer use and maintenance		

Printer

HP Latex 2700 Printer	<input type="checkbox"/>
HP Latex 2700W Printer	<input type="checkbox"/>

General access and equipment unloading

	Yes	No	Comments
Is there an easily accessible unloading area, with sufficient space to unload and maneuver the equipment?	<input type="checkbox"/>	<input type="checkbox"/>	
Has the route to the installation area been checked to meet all requirements (height, width, and clearance of ceilings, doorways, ramps, and corridors) and is the conveyance route clear?	<input type="checkbox"/>	<input type="checkbox"/>	
Is a power outlet available near the site where you plan to disassemble the package (for the electric screwdriver used to disassemble the package)?	<input type="checkbox"/>	<input type="checkbox"/>	
Have specialist movers been contracted to unload and move the equipment on the date required?	<input type="checkbox"/>	<input type="checkbox"/>	
Are the specialist movers aware of the specifications provided in this document?	<input type="checkbox"/>	<input type="checkbox"/>	
Is there enough space and manpower required to download the printer with the ramps?	<input type="checkbox"/>	<input type="checkbox"/>	
If a forklift is needed to unload the printer, has a suitable one been contracted for installation? If you plan to move the printer with a forklift, make sure you also have the required accessory.	<input type="checkbox"/>	<input type="checkbox"/>	
Are there skates available to help position the package?	<input type="checkbox"/>	<input type="checkbox"/>	(Optional)
Is there a pallet jack available to help position the package?	<input type="checkbox"/>	<input type="checkbox"/>	(Optional)
Will you install the printer on a second level or higher? If so, is there a suitable crane contracted for installation? Are the appropriate crane attachments available? If you plan to move the printer without the package, make sure you also have the required accessory.	<input type="checkbox"/>	<input type="checkbox"/>	

Room layout and flooring

	Yes	No	Comments
Is there sufficient space around the equipment?	<input type="checkbox"/>	<input type="checkbox"/>	
Has all room construction and painting been completed?	<input type="checkbox"/>	<input type="checkbox"/>	
Does the floor load-bearing capacity meet the specifications in the site preparation guide?	<input type="checkbox"/>	<input type="checkbox"/>	
Does the floor surface meet the specifications in the site preparation guide? If special reinforcements are necessary, are they completed?	<input type="checkbox"/>	<input type="checkbox"/>	
Is the floor prepared to install the heavy-duty rolls accessory?	<input type="checkbox"/>	<input type="checkbox"/>	(Optional)

Safety requirements

	Yes	No	Comments
Is there an emergency exit in the print production area, with easy access and free from any obstruction?	<input type="checkbox"/>	<input type="checkbox"/>	
Have the two fire extinguishers been fitted in the prescribed locations in the print production and storage areas? Is the print production fire extinguisher rated for electrical fire?	<input type="checkbox"/>	<input type="checkbox"/>	

Safety requirements (continued)

	Yes	No	Comments
Does the area meet the Restricted Access Location requirements in the zone surrounding the printer?	<input type="checkbox"/>		(Required)
Do the users who operate the printer have appropriate technical training and experience necessary to be aware of the hazards to which they may be exposed in performing a task and to take appropriate measures to minimize the risks?	<input type="checkbox"/>		(Required)
Will printer operations be supervised at all times?	<input type="checkbox"/>		(Required)

Electrical installation

	Yes	No	Comments
Has the site been prepared for the chosen power option?			
Configuration 1 branch circuit breaker: 4 poles, 40/50 A	<input type="checkbox"/>		
Configuration 2 branch circuit breaker: 3 poles, 63/70 A	<input type="checkbox"/>		
Configuration 3 branch circuit breaker:			
• Three-phase: 4 poles, 40/50 A	<input type="checkbox"/>		(Required)
• Two-phase control: 2 poles, 15/16/20 A	<input type="checkbox"/>		
Configuration 4 branch circuit breaker:			
• Three-phase: 3 poles, 63/70 A	<input type="checkbox"/>		
• Two-phase control: 2 poles, 15/16/20 A	<input type="checkbox"/>		
Is the chosen power system within its nominal range?			
Configuration 1	<input type="checkbox"/>		
Configuration 2	<input type="checkbox"/>		(Required)
Configuration 3	<input type="checkbox"/>		
Configuration 4	<input type="checkbox"/>		
Is the grounding conductor properly installed, as shown in the site preparation guide?	<input type="checkbox"/>		(Required)
Have you booked the services of an electrician for the day of installation?	<input type="checkbox"/>		(Required)
Is the electrician aware of all requirements and specifications highlighted in this document?	<input type="checkbox"/>		(Required)
Is the Power Distribution Unit (PDU) correctly installed?	<input type="checkbox"/>		(Required)
Are Residual-Current Circuit Breakers (RCCB), also known as Ground Fault Circuit Interrupters (GFCI), required by local laws? if so, have they a sensitivity of 100 mA or higher?	<input type="checkbox"/>	<input type="checkbox"/>	

Electrical configuration

	Yes	No	Comments
Do you need an Uninterrupted Power Supply (UPS)? If so, is it correctly installed?	<input type="checkbox"/>	<input type="checkbox"/>	
No power cords are supplied with the printer; does the electrician understand that power cord(s) must be provided according to printer specifications and local laws?	<input type="checkbox"/>	<input type="checkbox"/>	
If local regulations specify that you must use electrical plugs to connect the printer to the power supply, does the electrician have the required plugs ready for installation?	<input type="checkbox"/>	<input type="checkbox"/>	

Networking requirements

	Yes	No	Comments
Have network connections been supplied?	<input type="checkbox"/>	<input type="checkbox"/>	
Do you have a LAN cable long enough to connect the printer to the network?	<input type="checkbox"/>	<input type="checkbox"/>	
Do you have an Internet connection?	<input type="checkbox"/>	<input type="checkbox"/>	

Equipment preparation

	Yes	No	Comments
Is the air compressor or pressurized air line ready for the day installation?	<input type="checkbox"/>	<input type="checkbox"/>	
Have the correct supplies been ordered for deliver on or before the date of the printer's installation? Minimum requirements: One set of ink cartridges and 10 l of distilled water Recommended: One set of ink cartridges, an extra set of ink cartridges, and the correct substrate for training purposes	<input type="checkbox"/>	<input type="checkbox"/>	

RIP requirements

	Yes	No	Comments
Has the HP Large Format Onyx Thrive RIP software (D9Z41B) been ordered, and is the computer to be used available with the required specifications?	<input type="checkbox"/>	<input type="checkbox"/>	
Has the HP Large Format Caldera Grand RIP software (L5E74C) been ordered, and is the computer to be used available with the required specifications?	<input type="checkbox"/>	<input type="checkbox"/>	
If neither of the HP Large Format RIPs is to be used, is there a computer available with a RIP application installed that supports the printer?	<input type="checkbox"/>	<input type="checkbox"/>	
Do you have a spectrophotometer that is compatible with the RIP?	<input type="checkbox"/>	<input type="checkbox"/>	

Environmental requirements

	Yes	No	Comments
Have the temperature and humidity requirements been satisfactorily met in the print production area, and is there adequate ventilation or air conditioning?	<input type="checkbox"/>	<input type="checkbox"/>	
Have the temperature and humidity requirements been satisfactorily met in the storage area?	<input type="checkbox"/>	<input type="checkbox"/>	
Is the print production area free from dirt and dust?	<input type="checkbox"/>	<input type="checkbox"/>	
Does the print production area have sufficient lighting?	<input type="checkbox"/>	<input type="checkbox"/>	
Have you met or exceeded all the requirements specified in the site preparation guide?	<input type="checkbox"/>		(Required)
Have you met or exceeded all the ventilation and air conditioning requirements: <ul style="list-style-type: none"> • 140 m³ (4944 ft³) ...or met the requirements for special room sizes?	<input type="checkbox"/>	<input type="checkbox"/>	

Sign-off details

Date of site preparation completion

Site preparation guide edition number or copyright date

Customer signature

Materials and applications

	Yes	No	Comments
Self-adhesive vinyls	<input type="checkbox"/>	<input type="checkbox"/>	
PVC banners	<input type="checkbox"/>	<input type="checkbox"/>	
Papers	<input type="checkbox"/>	<input type="checkbox"/>	
Textiles	<input type="checkbox"/>	<input type="checkbox"/>	
Flexible films	<input type="checkbox"/>	<input type="checkbox"/>	
Other materials (to fill in)	Yes	No	Comments
	<input type="checkbox"/>	<input type="checkbox"/>	
	<input type="checkbox"/>	<input type="checkbox"/>	
	<input type="checkbox"/>	<input type="checkbox"/>	
	<input type="checkbox"/>	<input type="checkbox"/>	
	<input type="checkbox"/>	<input type="checkbox"/>	

Materials and applications (continued)

	Yes	No	Comments
	<input type="checkbox"/>	<input type="checkbox"/>	
	<input type="checkbox"/>	<input type="checkbox"/>	
	<input type="checkbox"/>	<input type="checkbox"/>	
	<input type="checkbox"/>	<input type="checkbox"/>	
	<input type="checkbox"/>	<input type="checkbox"/>	
Which applications do you plan to use?			
Outdoor temporary signage	<input type="checkbox"/>		
Outdoor permanent signage	<input type="checkbox"/>		
Decoration	<input type="checkbox"/>		
Indoor signage (panels and FSDU)	<input type="checkbox"/>		
Window graphics	<input type="checkbox"/>		
Other applications (to fill in)			
	<input type="checkbox"/>		
	<input type="checkbox"/>		
	<input type="checkbox"/>		
	<input type="checkbox"/>		
	<input type="checkbox"/>		
	<input type="checkbox"/>		

Training

	Yes	No	Comments
Are you aware of the training available for the printer?	<input type="checkbox"/>	<input type="checkbox"/>	
Will the operator be available for the full amount of time required for the installation training (2–2.5 days)?	<input type="checkbox"/>	<input type="checkbox"/>	