

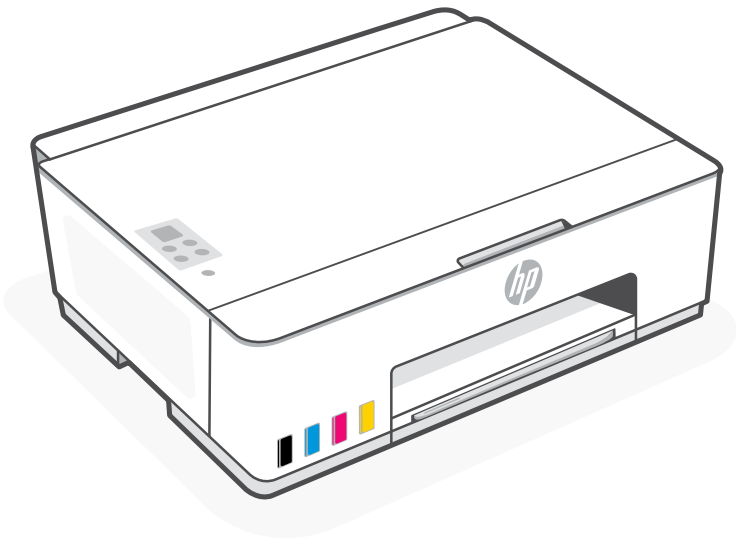

Setup and Reference Guide

TH	คู่มือการตั้งค่าและการอ้างอิง	9
ZHTW	設定和參考指南	15
VI	Hướng dẫn thiết lập và tham khảo	21
ID	Panduan Penyiapan dan Referensi	27



HP Smart Tank
210-220 series

1 Remove packaging and power on

1. Remove all the tape and packing materials.
Note: Keep the packaging materials for repacking in case you need to move the printer.

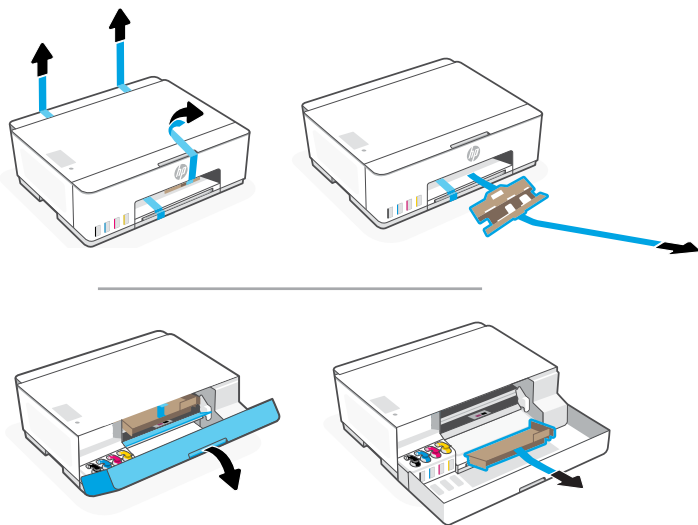

2. Close the front door.

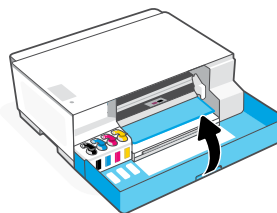

3. Plug in and power on the printer.
Keep the printer on during setup.

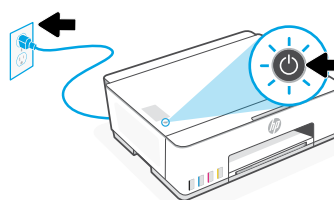

2 Choose an option for setting up your printer

Recommended

Option 1: Guided setup with HP Smart

1. Go to 123.hp.com on a mobile device or computer to install the HP Smart software.

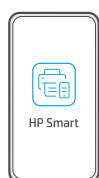

2. Open **HP Smart**. If prompted, create or sign in to an HP account.
3. On the Home screen, choose the option to add a printer, and follow the instructions to connect the printer to your network (only 2.4 GHz Wi-Fi supported).
4. View animations to fill ink tanks, install printheads, and load paper in HP Smart.
HP Smart has everything you need to finish setup.

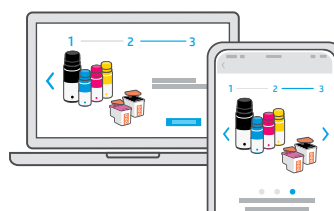
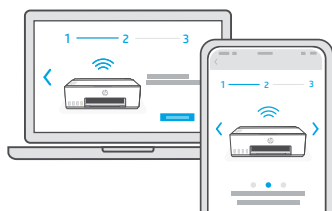

Option 2: Manual setup



Follow illustrations in this guide to set up the hardware, then use the HP Smart software to connect to Wi-Fi and finish setup.



Manual Setup

1 Fill the ink tanks



1. Open the front door.

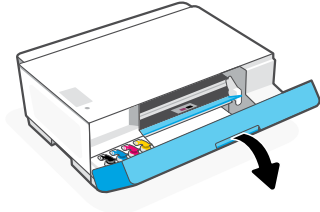

2. Open the cap of the ink tank you want to fill.

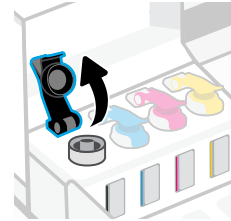

3. Twist open the ink bottle.



4. Place the bottle upside down onto the tank and click into place. Wait for the ink to fill the tank.
Note: The black bottle will have ink left in the bottle.

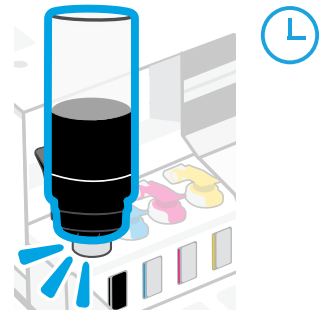

5. Close the ink bottle, firmly pushing the cap onto the bottle.

Note: If there is ink left in the bottle, close the bottle properly and store upright in a cool, dark place.

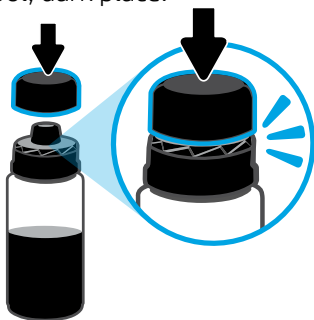

6. Close the tank cap securely.

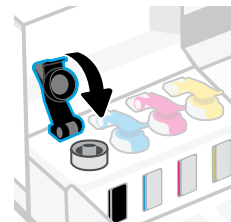

7. Repeat to fill all tanks.

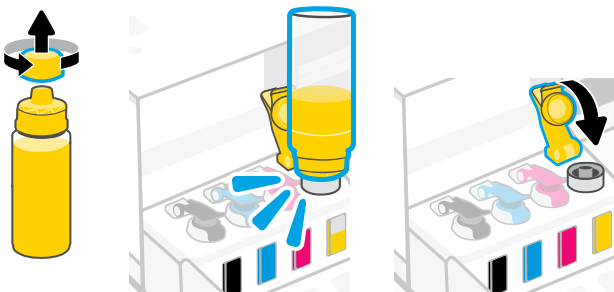

8. After filling all tanks, close the front door.

Wait approximately 15 seconds for the printer to check ink.

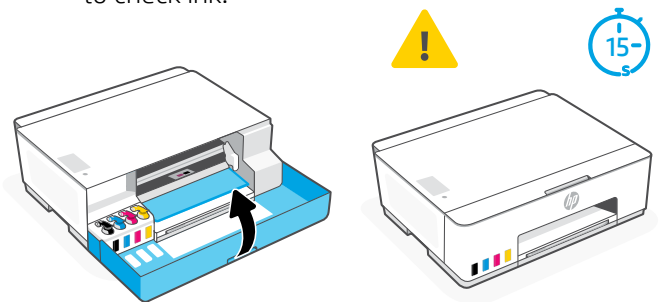

2 Install printheads



Before installing printheads, ensure the following:

- The printer is on.
- All four ink tanks are filled.
- You have closed the front door for approximately 15 seconds after filling ink.

1. Open the front door. Make sure the print carriage has moved to the center; if not, close the door for 15 seconds.

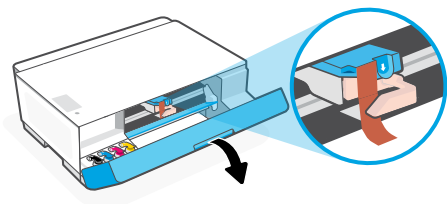

2. Remove the orange tape from the printhead cover. Press and release the blue latch to open the printhead cover.

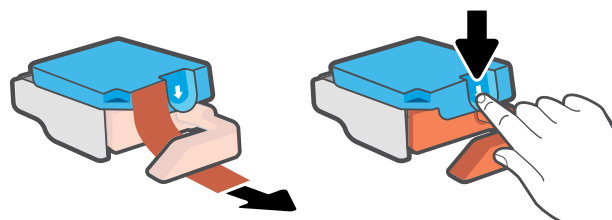

3. Remove and discard the orange guard.
Note: Keep the guard upright; handle carefully to avoid ink leaks.

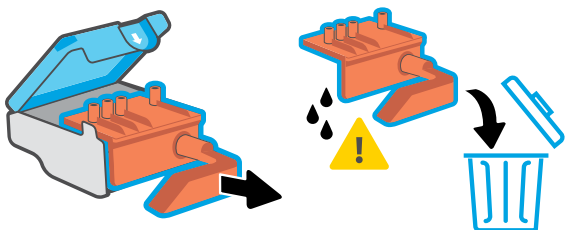

4. Remove the orange cap and tape from both printheads.
Caution: Do not touch the electric contacts or print nozzles under the tape.

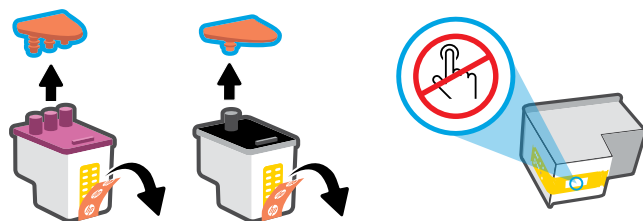

5. Insert the printhead and click into place. Repeat to install the other printhead.
Note: Make sure the electric contacts are facing inside.

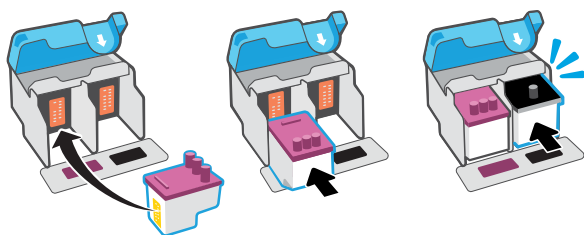

6. Close the printhead cover and the front door.
Note: Make sure the printhead cover is properly closed.

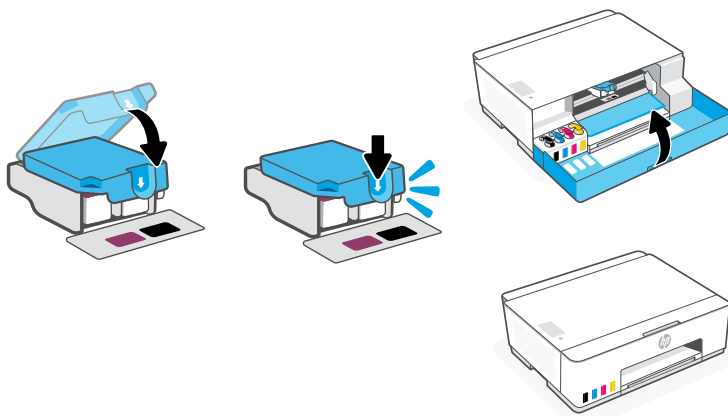

3 Load paper

1. Pull up the paper tray and extender, and slide the paper guide to the left.

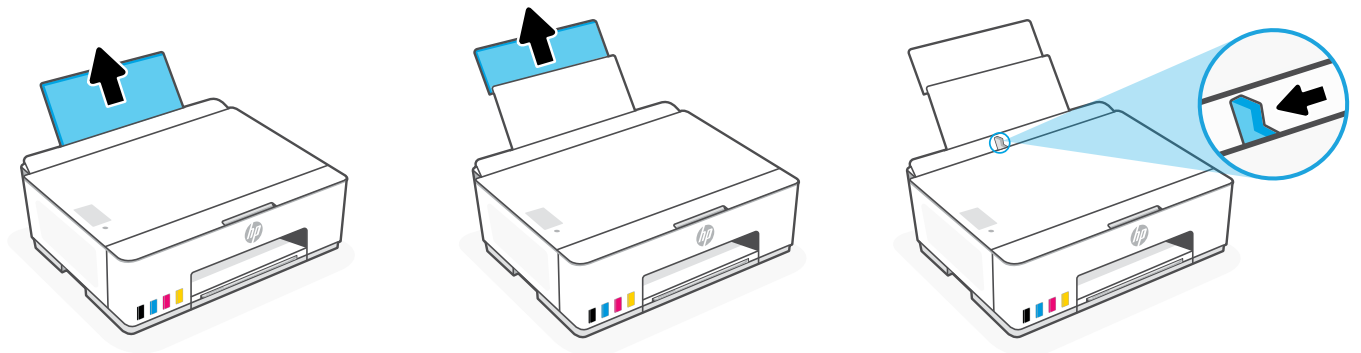

2. Load new, unused Letter or A4 paper, and adjust the paper guide. Open the output tray extender.

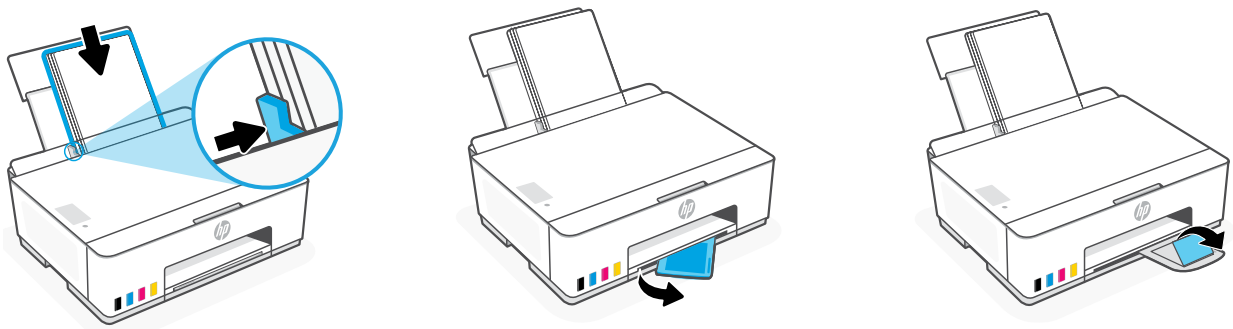

4 Install the HP Smart software

1. Make sure the **Wi-Fi** light  on the printer control panel is blinking. If not, see the **Help and tips for Wi-Fi and connectivity** section in this guide.
2. Install the HP Smart software from **123.hp.com** on a computer or mobile device.

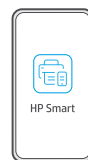
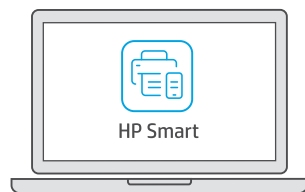

123.hp.com

3. Open **HP Smart**. If prompted, create or sign in to an HP account.
4. On the Home screen, choose the option to add a printer, and follow the instructions to connect the printer to your network (only 2.4 GHz Wi-Fi supported).



Get help with setup
Find setup information and videos online.
hp.com/support/printer-setup





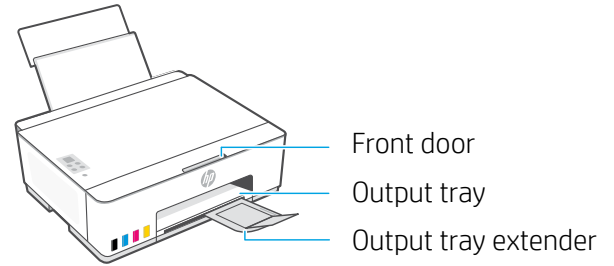
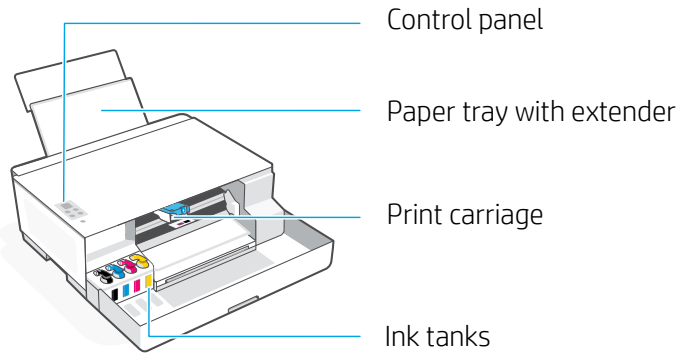

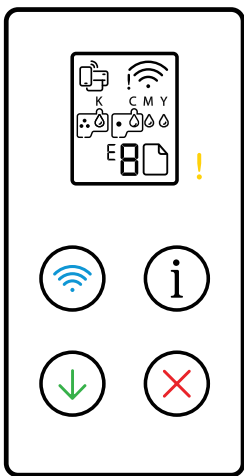

Printer Reference







Control panel buttons and lights

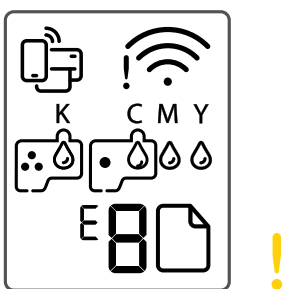

-  **Power** button: Turn the printer on or off.
-  **Attention** light: Indicates problems with paper, ink, or printheads.
-  **Wi-Fi** button/light: Turn on or off Wi-Fi. The light indicates Wi-Fi status.
-  **Information** button: Print summary of printer settings and status.
-  **Resume** button: Resume a job after a disruption.
-  **Cancel** button: Cancel the current job.

Control panel display

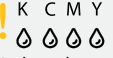





-  Wi-Fi Direct status.
-  Wi-Fi status and signal strength.
-  **K C M Y**
Ink related issues, including low on ink.
-  Printheads related issues.
Note: Do not open the printhead cover unless instructed.
-  Media related issues, including out of paper.
- E1/E2**
Paper size/length mismatch.
- E3**
Print carriage jam or printhead cover not closed.
- E4**
Paper jam.
- E7**
Out of ink.

Help and tips for Wi-Fi and connectivity

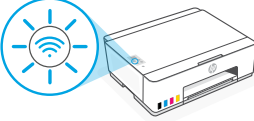
If the software is unable to find your printer during setup, check the following conditions to resolve the issue.

Note: This printer only supports a 2.4 GHz Wi-Fi connection.

Potential Issue	Solution
<p>Printer Wi-Fi setup mode timed out</p> 	<p>If the Wi-Fi light is off, the printer might not be in Wi-Fi setup mode. Restart Wi-Fi setup mode:</p> <ol style="list-style-type: none"> 1. Press and hold  for 5 seconds until the control panel buttons light up. 2. Press and hold  and  for 5 seconds until the Wi-Fi light blinks blue. 3. Wait for one minute. Close and reopen HP Smart, and then try connecting again.
<p>Computer or mobile device too far from printer</p>	<p>Move your computer or mobile device closer to the printer. Your device might be out of range of the printer's Wi-Fi signal.</p>
<p>Computer connected to a Virtual Private Network (VPN) or remote work network</p>	<p>Disconnect from a VPN before installing HP Smart software. You can't install apps from the Microsoft Store when connected to a VPN. Connect to the VPN again after finishing printer setup.</p> <p>Note: Consider your location and the security of the Wi-Fi network before disconnecting from a VPN.</p>
<p>Bluetooth is turned off on your computer or mobile device</p> <p>Location is turned off on your mobile device</p>	<p>Turn on Bluetooth for the computer or mobile device being used to complete printer setup. For mobile devices, turn on Location services also. Bluetooth and Location help the software find your network and printer.</p> <p>Note: Your location is not being determined and no location information is being sent to HP as part of the setup process.</p>

Move printer properly to prevent ink leaks

 hp.com/support/movingsmarttank

1. Turn off the printer and remove the power cord.

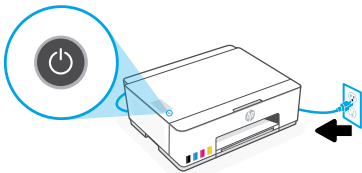

3. Press down on the side of the printhead cover to release the cover.

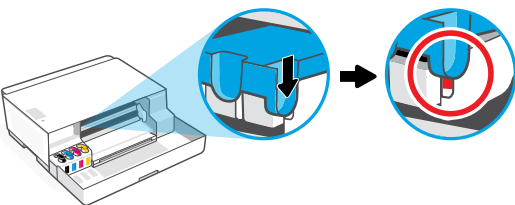

5. Pack the printer in a box (if available). While moving the printer, keep it horizontal to prevent ink leakage.

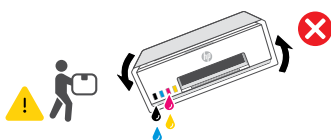

7. Connect the power cord and turn on the printer.

2. Open the front door. Make sure the print carriage is all the way to the left; if not, manually move it to the left.

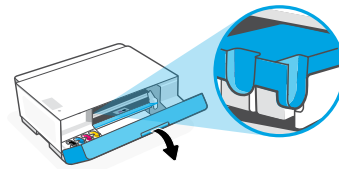

4. Insert a cardboard restraint. Close the front door.

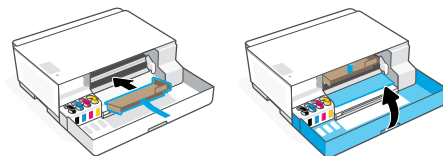

6. After unpacking, push down the blue latch to close the printhead cover. Make sure the cover is properly closed.

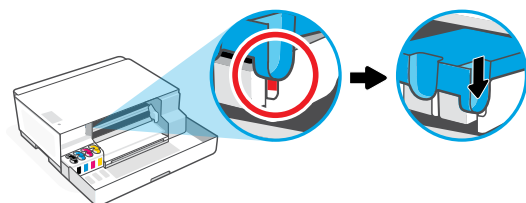

For printer troubleshooting and videos, visit hp.com/support

1 แกะบรรจุภัณฑ์และเปิดเครื่อง

1. แกะเทปและวัสดุบรรจุภัณฑ์ทั้งหมดออก
หมายเหตุ: เก็บวัสดุบรรจุภัณฑ์เอาไว้สำหรับผนึกบรรจุภัณฑ์อีกครั้งในกรณีที่คุณจำเป็นต้องขนย้ายเครื่องพิมพ์

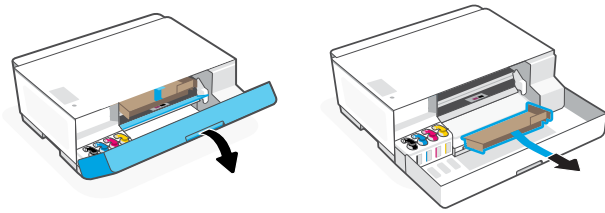
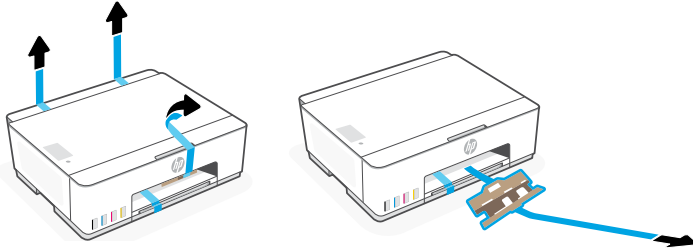

2. ปิดฝาหน้า

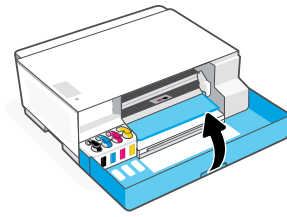

3. เสียบปลั๊กแล้วเปิดเครื่องพิมพ์ เปิดเครื่องพิมพ์ไว้ในระหว่างการตั้งค่า

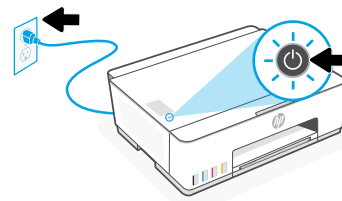

2 เลือกตัวเลือกสำหรับการตั้งค่าเครื่องพิมพ์ของคุณ

แนะนำ

ตัวเลือก 1: การตั้งค่าแบบมีคำแนะนำโดยใช้ HP Smart

1. ไปที่ 123.hp.com บนอุปกรณ์เคลื่อนที่หรือคอมพิวเตอร์ เพื่อติดตั้งซอฟต์แวร์ HP Smart

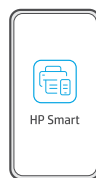

123.hp.com

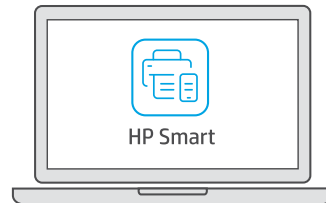

2. เปิด HP Smart หากได้รับข้อความแจ้งให้สร้างหรือลงชื่อเข้าใช้บัญชีผู้ใช้ HP
3. ในหน้าจอหลักให้เลือกตัวเลือกเพิ่มเครื่องพิมพ์ แล้วทำตามคำแนะนำในการเชื่อมต่อเครื่องพิมพ์เข้ากับเครือข่ายของคุณ (รองรับเฉพาะ Wi-Fi 2.4 GHz)
4. ดูภาพเคลื่อนไหวแนะนำการเติมหมึกในถัง ติดตั้งหัวพิมพ์ และใส่กระดาษจากใน HP Smart
HP Smart มีทุกอย่างที่คุณจำเป็นต้องใช้ ในการตั้งค่าให้เสร็จ

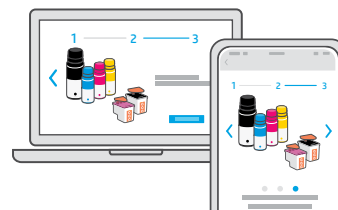
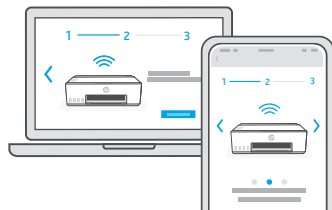

ตัวเลือก 2: ตั้งค่าด้วยตัวเอง



ทำตามภาพประกอบในคู่มือนี้เพื่อตั้งค่าฮาร์ดแวร์ จากนั้นใช้ซอฟต์แวร์ HP Smart เพื่อเชื่อมต่อกับ Wi-Fi และตั้งค่าให้เสร็จ



ตั้งค่าด้วยตัวเอง

1 เต็มหมึกในถัง



1. เปิดฝาหน้า

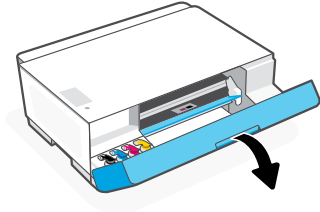

2. เปิดฝาถังหมึกที่ความต้องการเติม

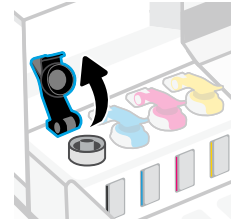

3. บิดเพื่อเปิดขวดหมึก



4. วางขวดคว่ำลงบนถังหมึก แล้วขยับให้ล็อกเข้าที่ รอจนกว่าจะเต็มหมึกในถังเสร็จ

หมายเหตุ: ขวดสีดำจะมีหมึกเหลืออยู่ภายในขวด

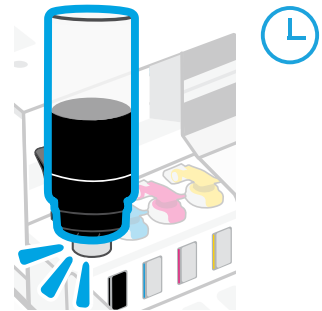

5. ปิดขวดหมึก กดฝาลงบนขวดให้แน่น

หมายเหตุ: หากมีหมึกเหลืออยู่ภายในขวด ให้ปิดขวดให้เรียบร้อย แล้วจัดเก็บโดยวางขวดตั้งตรงในที่เย็นและมืด

6. ปิดฝาถังหมึกให้แน่นสนิท

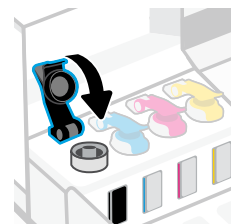
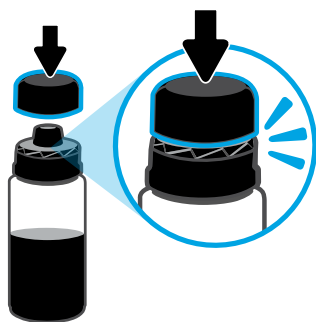

7. เต็มหมึกเช่นนี้ให้ครบทุกถัง

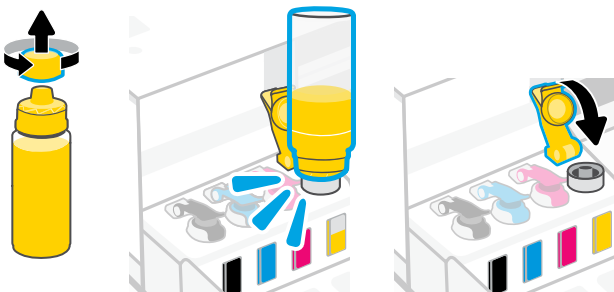

8. หลังจากเติมหมึกครบทุกถังแล้วให้ปิดฝาหน้า

⚠️ รอให้เครื่องพิมพ์ตรวจสอบหมึกประมาณ 15 วินาที

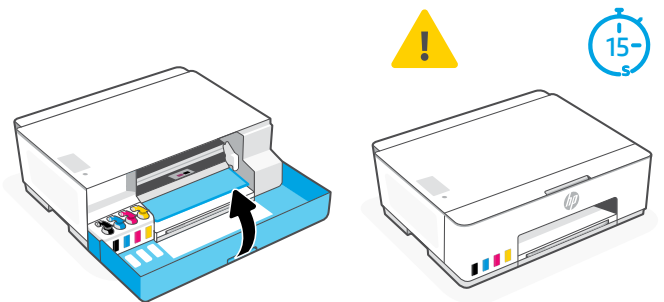

2 ติดตั้งหัวพิมพ์



ก่อนติดตั้งหัวพิมพ์ โปรดตรวจสอบรายละเอียดต่อไปนี้ให้แน่ใจ:

- เครื่องพิมพ์เปิดอยู่
- ปิดฝาหน้าแล้วรอประมาณ 15 วินาทีหลังจากเติมหมึกก็ในถึงเสร็จ
- เต็มหมึกครบทั้งสี่ถังแล้ว

1. เปิดฝาหน้า ตรวจสอบให้แน่ใจว่าแคร่พิมพ์ขยับมาอยู่ตรงกลาง หากไม่ให้ปิดฝาทิ้งไว้ 15 วินาที

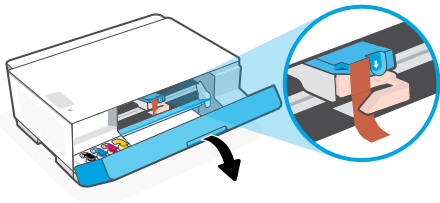

2. แกะแถบสีส้มออกจากฝาครอบหัวพิมพ์ กดสลักสีน้ำเงินแล้วปล่อยให้ฝาครอบหัวพิมพ์

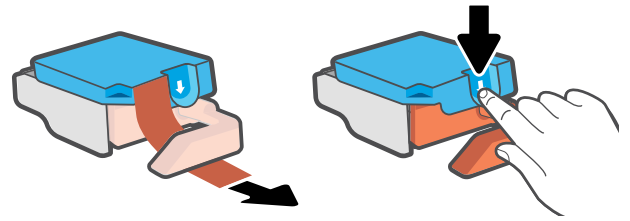

3. ถอดชิ้นส่วนป้องกันสีส้มออกและนำไปทิ้ง
หมายเหตุ: วางชิ้นส่วนป้องกันตั้งตรง ระมัดระวังอย่าให้หมึกรั่วซึม

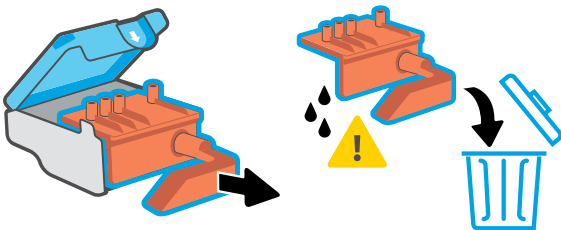

4. ถอดฝาและแถบสีส้มออกจากหัวพิมพ์ทั้งคู่
ข้อควรระวัง: อย่าแตะต้องบริเวณหน้าสัมผัสไฟฟ้าหรือหัวฉีดหมึกที่อยู่ใต้เพป

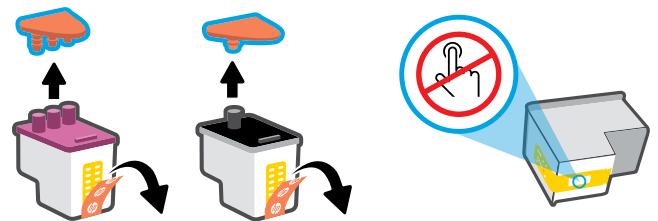

5. เสียบหัวพิมพ์จนล็อกเข้าที่ ดำเนินการซ้ำเพื่อติดตั้งหัวพิมพ์อื่น
หมายเหตุ: ตรวจสอบให้แน่ใจว่าได้หันหน้าสัมผัสไฟฟ้าเข้าด้านใน

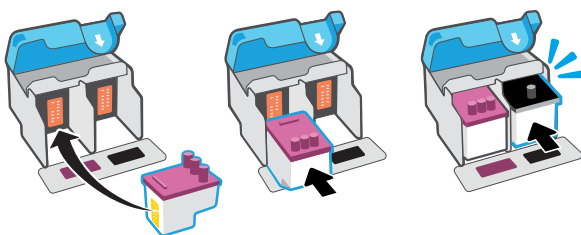

6. ปิดฝาครอบหัวพิมพ์และฝาหน้า
หมายเหตุ: ตรวจสอบให้แน่ใจว่าปิดฝาครอบหัวพิมพ์แน่นดีแล้ว

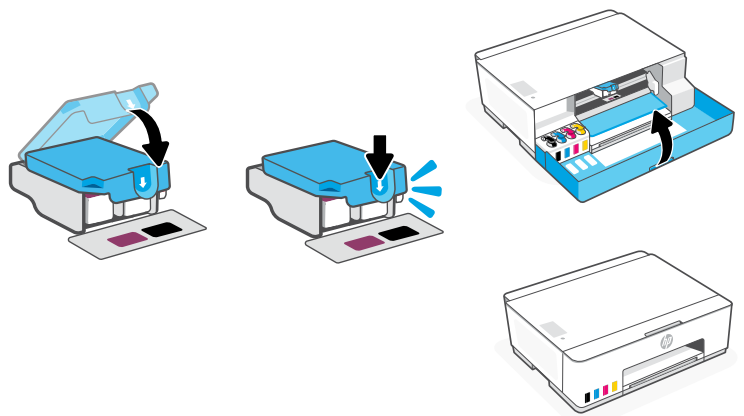

3 ใส่กระดาษ

1. ดึงถาดกระดาษและส่วนขยายขึ้น จากนั้นเลื่อนตัวกั้นกระดาษไปทางซ้าย

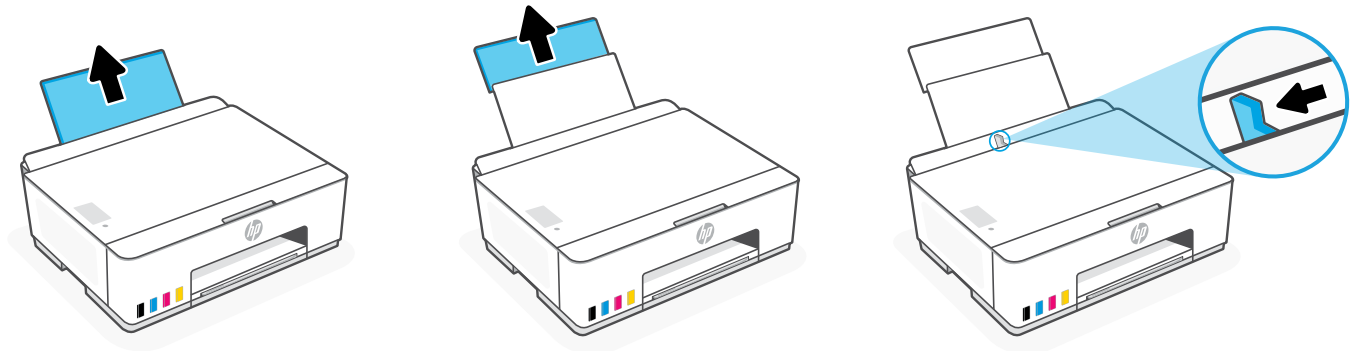

2. ใส่กระดาษ Letter หรือ A4 ใหม่ที่ยังไม่ได้ใช้งาน แล้วปรับตัวกั้นกระดาษ เปิดส่วนขยายของถาดรับกระดาษ

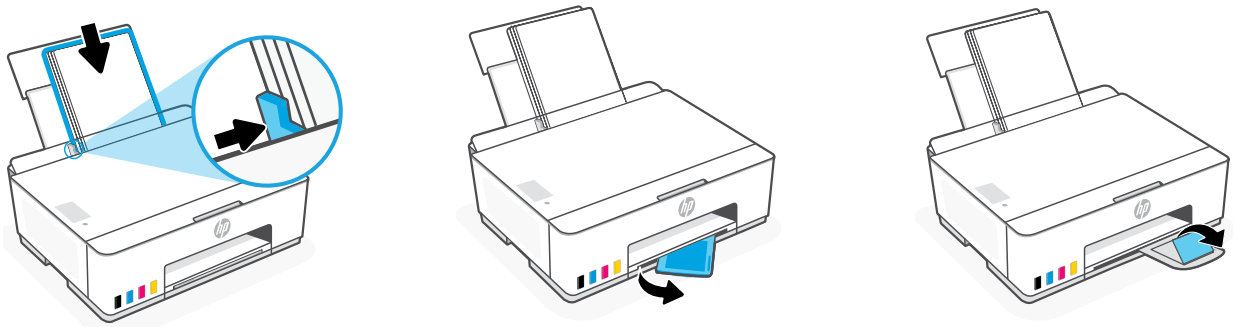

4 ติดตั้งซอฟต์แวร์ HP Smart

1. ตรวจสอบให้แน่ใจว่าไฟแสดงสถานะ Wi-Fi บนแผงควบคุมเครื่องพิมพ์กำลังกะพริบ หากไม่ให้ดูที่ส่วน วิธีใช้และเคล็ดลับเกี่ยวกับ Wi-Fi และการเชื่อมต่อในคู่มือฉบับนี้
2. ติดตั้งซอฟต์แวร์ HP Smart จาก 123.hp.com บนคอมพิวเตอร์หรืออุปกรณ์เคลื่อนที่

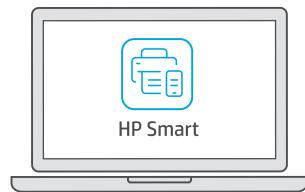

123.hp.com

3. เปิด HP Smart หากได้รับข้อความแจ้งให้สร้างหรือลงชื่อเข้าใช้บัญชีผู้ใช้ HP
4. ในหน้าจอหลัก ให้เลือกตัวเลือกเพิ่มเครื่องพิมพ์ แล้วทำตามคำแนะนำในการเชื่อมต่อเครื่องพิมพ์เข้ากับเครือข่ายของคุณ (รองรับเฉพาะ Wi-Fi 2.4 GHz)



ขอความช่วยเหลือเกี่ยวกับการตั้งค่า
ค้นหาข้อมูลและวิดีโอเกี่ยวกับการตั้งค่าผ่านทาง
ออนไลน์
hp.com/support/printer-setup



ข้อมูลอ้างอิงเครื่องพิมพ์

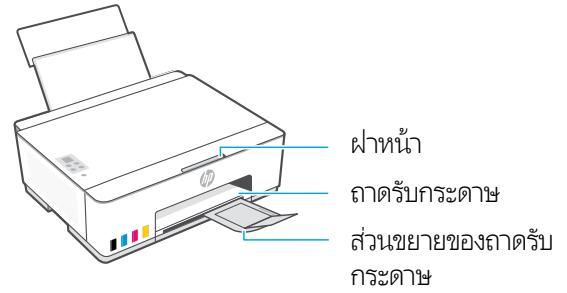
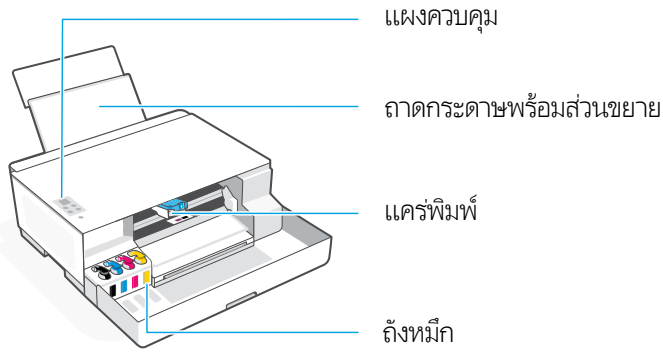

ปุ่มและไฟแสดงสถานะบนแผงควบคุม

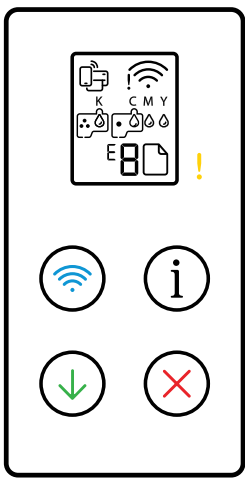

- ⏻ ปุ่ม **เปิด/ปิด**: ใช้เปิดหรือปิดการทำงานของเครื่องพิมพ์
- ! ไฟแสดงสถานะ **เตือน**: รายงานว่ามีปัญหาเกี่ยวกับกระดาษ หมึก หรือหัวพิมพ์
- 📶 ปุ่ม/ไฟแสดงสถานะ **Wi-Fi**: เปิดหรือปิด Wi-Fi ไฟแสดงสถานะจะระบุถึงสถานะของ Wi-Fi
- i ปุ่ม **ข้อมูล**: พิมพ์สรุปข้อมูลการตั้งค่าและสถานะของเครื่องพิมพ์
- ⬇️ ปุ่ม **กลับสู่การทำงาน**: กลับสู่การทำงานหลังจากหยุดชั่วคราว
- ✖️ ปุ่ม **ยกเลิก**: ยกเลิกงานปัจจุบัน

จอแสดงผลแผงควบคุม

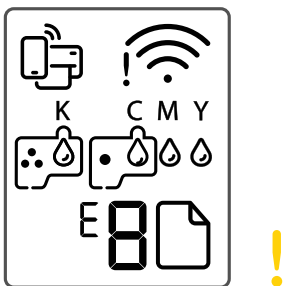

📶 สถานะ Wi-Fi Direct

📶 สถานะ Wi-Fi และความแรงของสัญญาณ

! K C M Y
• • • •
ปัญหาเกี่ยวกับหมึก รวมถึงหมึกใกล้หมด

! 🗨️
ปัญหาเกี่ยวกับหัวพิมพ์

หมายเหตุ: อย่าเปิดฝาครอบหัวพิมพ์ เว้นแต่ได้รับคำแนะนำให้เปิด

! 📄
ปัญหาเกี่ยวกับวัสดุพิมพ์ รวมถึงกระดาษหมด

E1/E2
ขนาดกระดาษ/ความยาวไม่ตรงกัน

E3
แคร่พิมพ์ ติด หรือไม่ได้ปิดฝาครอบหัวพิมพ์

E4
กระดาษติด

E7
หมึกหมด

วิธีใช้และเคล็ดลับเกี่ยวกับ Wi-Fi และการเชื่อมต่อ

หากซอฟต์แวร์ไม่พบเครื่องพิมพ์ของคุณในระหว่างการตั้งค่าให้ตรวจสอบสถานะต่อไปนี้เพื่อแก้ไขปัญหา

หมายเหตุ: เครื่องพิมพ์นี้รองรับเฉพาะการเชื่อมต่อ Wi-Fi 2.4 GHz

สาเหตุที่เป็นไปได้	วิธีแก้ไข
<p>โหมดตั้งค่า Wi-Fi ของเครื่องพิมพ์หมดเวลา</p> 	<p>หากไฟแสดงสถานะ Wi-Fi ไม่ติดสว่าง เครื่องพิมพ์อาจไม่ได้อยู่ในโหมดตั้งค่า Wi-Fi รีเซ็ตโหมดตั้งค่า Wi-Fi:</p> <ol style="list-style-type: none"> กด ① ค้างไว้ 5 วินาที จนกว่าไฟปุ่มต่างๆ บนแผงควบคุมจะติดสว่าง กด ② และ ③ ค้างไว้ 5 วินาที จนกว่าไฟแสดงสถานะ Wi-Fi จะกะพริบเป็นสีน้ำเงิน รอหนึ่งนาที ปิดและเปิด HP Smart ใหม่ จากนั้นจึงลองเชื่อมต่ออีกครั้ง
<p>คอมพิวเตอร์หรืออุปกรณ์เคลื่อนที่อยู่ห่างจากเครื่องพิมพ์มากเกินไป</p>	<p>ขยับคอมพิวเตอร์หรืออุปกรณ์เคลื่อนที่ของคุณให้เข้าใกล้เครื่องพิมพ์มากขึ้น อุปกรณ์ของคุณอาจอยู่นอกระยะสัญญาณ Wi-Fi ของเครื่องพิมพ์</p>
<p>คอมพิวเตอร์เชื่อมต่อกับเครือข่ายส่วนตัวเสมือน (VPN) หรือเครือข่ายงานระยะไกล</p>	<p>ตัดการเชื่อมต่อจาก VPN ก่อนที่จะติดตั้งซอฟต์แวร์ HP Smart คุณไม่สามารถติดตั้งแอปจาก Microsoft Store ได้ในขณะที่เชื่อมต่อกับ VPN เชื่อมต่อกับ VPN อีกครั้งหลังจากเสร็จสิ้นการตั้งค่าเครื่องพิมพ์</p> <p>หมายเหตุ: พิจารณาตำแหน่งที่ตั้งของคุณและการรักษาความปลอดภัยของเครือข่าย Wi-Fi ก่อนที่จะตัดการเชื่อมต่อจาก VPN</p>
<p>Bluetooth บนคอมพิวเตอร์หรืออุปกรณ์เคลื่อนที่ของคุณถูกปิดไว้</p> <p>ตำแหน่งที่ตั้งบนอุปกรณ์เคลื่อนที่ของคุณถูกปิดไว้</p>	<p>เปิด Bluetooth ของคอมพิวเตอร์หรืออุปกรณ์เคลื่อนที่ที่ต้องการใช้ดำเนินการตั้งค่าเครื่องพิมพ์ให้เสร็จ สำหรับอุปกรณ์เคลื่อนที่ที่เปิดบริการตำแหน่งที่ตั้งด้วย Bluetooth และตำแหน่งที่ตั้งจะช่วยให้ซอฟต์แวร์สามารถค้นพบเครือข่ายและเครื่องพิมพ์ของคุณได้</p> <p>หมายเหตุ: ขั้นตอนนี้ไม่ใช่การระบุตำแหน่งที่ตั้งของคุณ และไม่ได้มีการส่งข้อมูลตำแหน่งที่ตั้งให้กับ HP ในระหว่างกระบวนการตั้งค่า</p>

ขนย้ายเครื่องพิมพ์อย่างถูกต้อง เพื่อป้องกันไม่ให้หมึกไหลซึม

 hp.com/support/movingsmarttank

1. ปิดเครื่องพิมพ์และถอดสายไฟออก

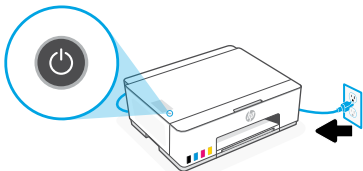

2. เปิดฝาหน้า ตรวจสอบให้แน่ใจว่าแคร่พิมพ์อยู่ทางด้านซ้าย หากไม่ ให้ขยับไปทางซ้ายด้วยตัวเอง

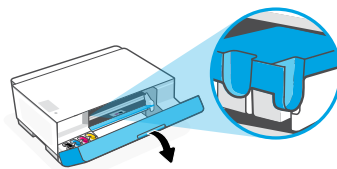

3. กดด้านข้างของฝาครอบหัวพิมพ์ลงเพื่อปลดล็อกฝาครอบ

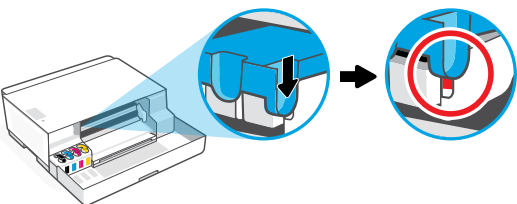

4. ใส่แผ่นกั้นกระดาษแข็ง ปิดฝาหน้า

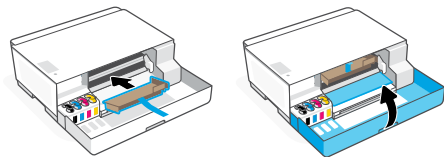

5. เก็บเครื่องพิมพ์เข้ากล่อง (หากมี)

ขณะขนย้ายเครื่องพิมพ์ให้เครื่องพิมพ์อยู่ในแนวราบตั้งตรงเสมอเพื่อป้องกันไม่ให้หมึกไหลซึม



6. หลังนำออกจากบรรจุภัณฑ์ให้กดสลักสีน้ำเงินลงเพื่อปิดฝาครอบหัวพิมพ์ ตรวจสอบว่าปิดฝาครอบแน่นดีแล้ว

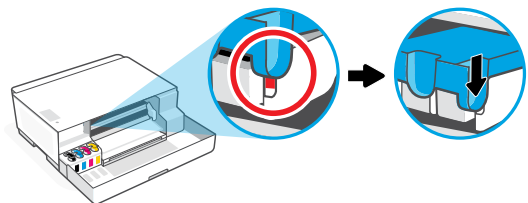

7. เสียบสายไฟแล้วเปิดเครื่องพิมพ์

ไปที่ hp.com/support เพื่อศึกษาวิธีการแก้ไขปัญหาเครื่องพิมพ์และวิดีโอแนะนำการใช้งาน

1 取下包裝並打開電源

1. 取下所有膠帶和包裝材料。
附註：保留包裝材料，以便有搬動印表機的需求時可用來重新包裝。

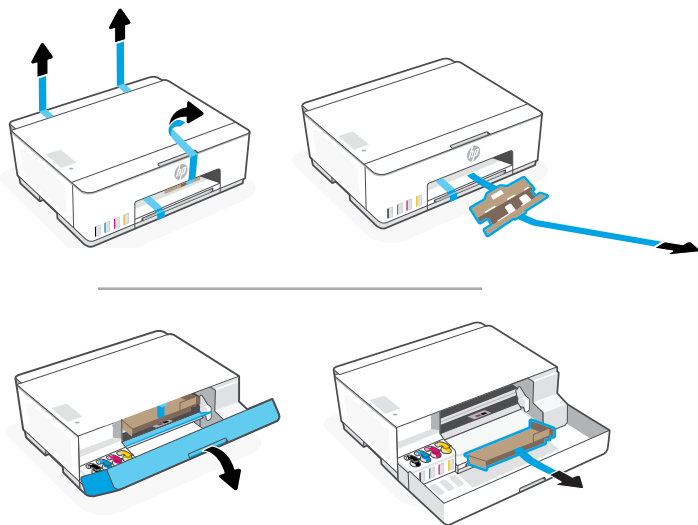

2. 關上前擋門。

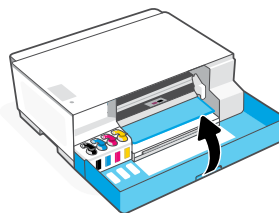

3. 插上電源線，然後開啟印表機。
在設定期間讓印表機維持開啟狀態。

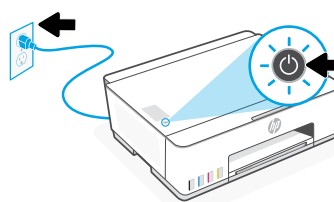

2 選擇選項以設定您的印表機

推薦

選項 1：HP Smart 的引導式設定

1. 透過行動裝置或電腦前往 123.hp.com 以安裝 HP Smart 軟體。

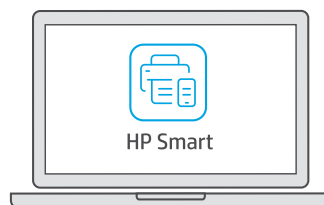
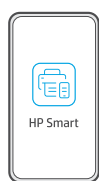

2. 開啟 HP Smart。若出現提示，請建立或登入 HP 帳戶。
3. 在首頁畫面上，選擇選項以新增印表機，並依照指示將印表機連線到您的網路（僅支援 2.4 GHz Wi-Fi）。
4. 在 HP Smart 內觀看填充墨罐、安裝列印頭，以及放入紙張的動畫教學課程。
完成設定所需的一切，盡在 HP Smart。

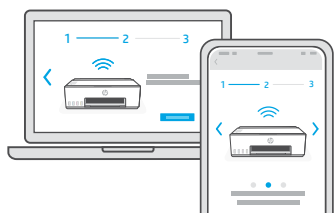

選項 2：手動設定



請按照本指南的圖解設定硬體，然後使用 HP Smart 軟體連線至 Wi-Fi 並完成設定。



手動設定

1 填充墨罐



1. 開啟前擋門。

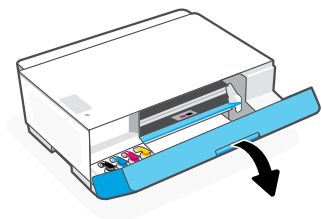

2. 打開您想要裝填之墨罐的蓋子。



3. 將墨水瓶旋開。



4. 將墨水瓶倒置在墨罐上，並卡入定位。等待墨罐墨水裝滿。
附註：黑色墨水瓶中會有剩餘墨水。

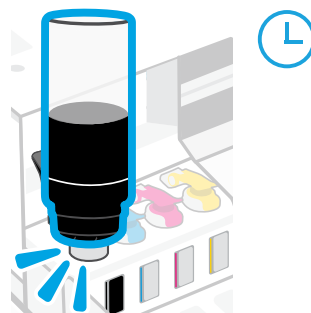

5. 關閉墨水瓶，並牢固地將蓋子蓋回瓶口。

附註：若墨水瓶內還有剩餘墨水，請正確蓋上墨水瓶，並以豎立方式存放在陰暗涼爽的位置。

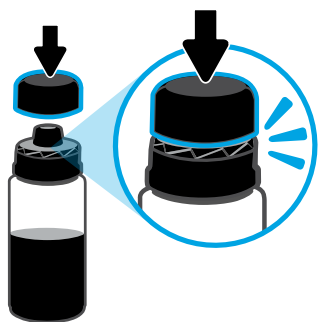

6. 關緊墨罐蓋。

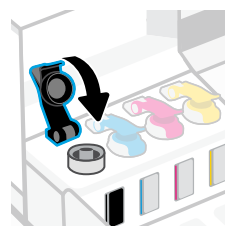

7. 重複以上步驟以裝填所有墨罐。

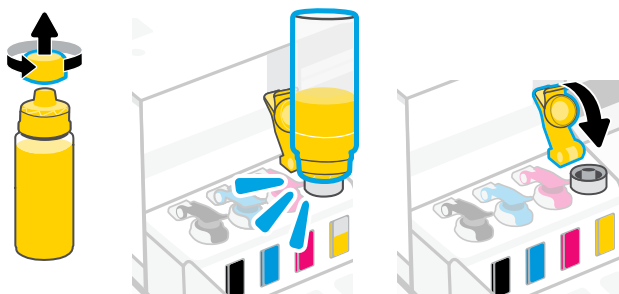

8. 裝填好所有墨罐後，關上前擋門。

⚠ 請等候約 15 秒，讓印表機檢查墨水。

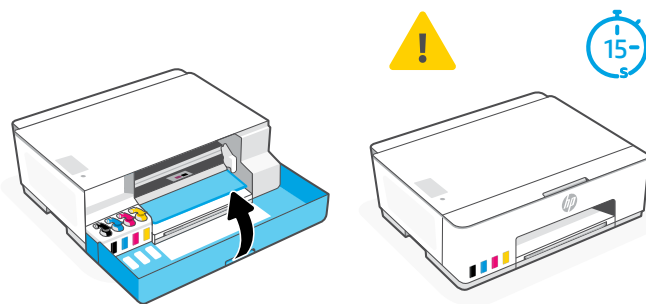

2 安裝列印頭



⚠ 在安裝列印頭前，請確認下列各項：

- 印表機已開啟。
- 您在裝填墨水後，已關閉前擋門約 15 秒。

1. 開啟前擋門。確認列印滑動架已移至中央；若尚未移至中央，請關閉擋門約 15 秒。

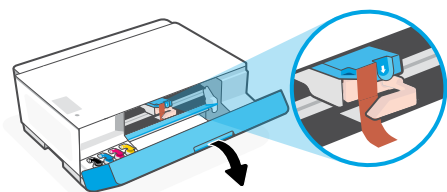

2. 將列印頭蓋板上的橙色膠帶取下。按壓並鬆開藍色卡榫以開啟列印頭蓋板。

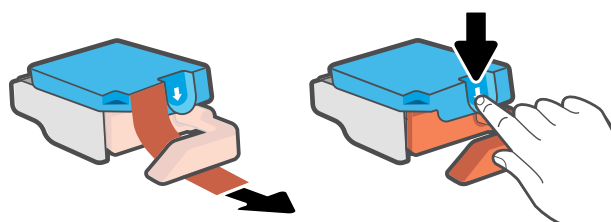

3. 將橙色保護裝置取下並丟棄。
附註：讓保護裝置維持豎立；請小心操作，以免墨水濺漏。

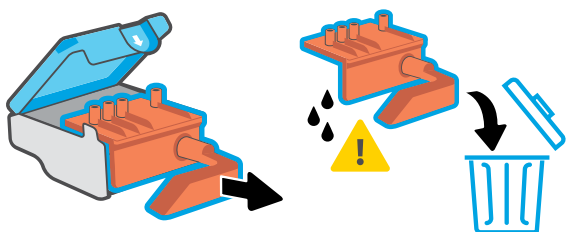

4. 將兩個列印頭上的橙色蓋子及膠帶取下。
注意：請勿觸碰膠帶下方的電氣接點及列印噴嘴。

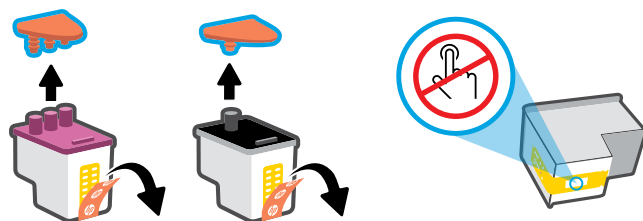

5. 將列印頭插入並卡入定位。
重複以上步驟來安裝其他列印頭。
附註：請確保電氣接點朝向內側。

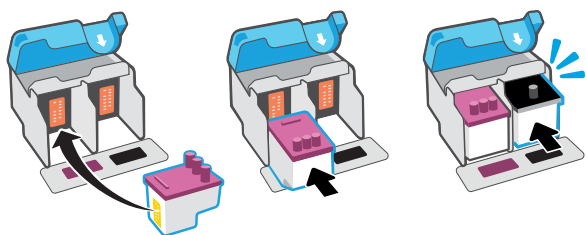

6. 關閉列印頭蓋板和前擋門。
附註：確認列印頭蓋板正確蓋上。

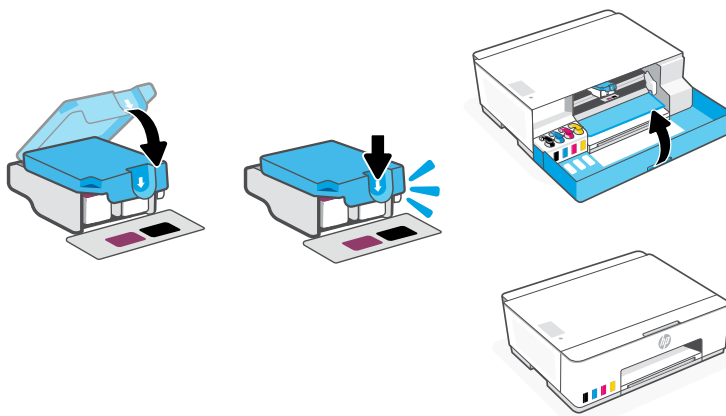

3 放入紙張

1. 將紙匣及延伸架拉起，然後將紙張導板滑至左側。

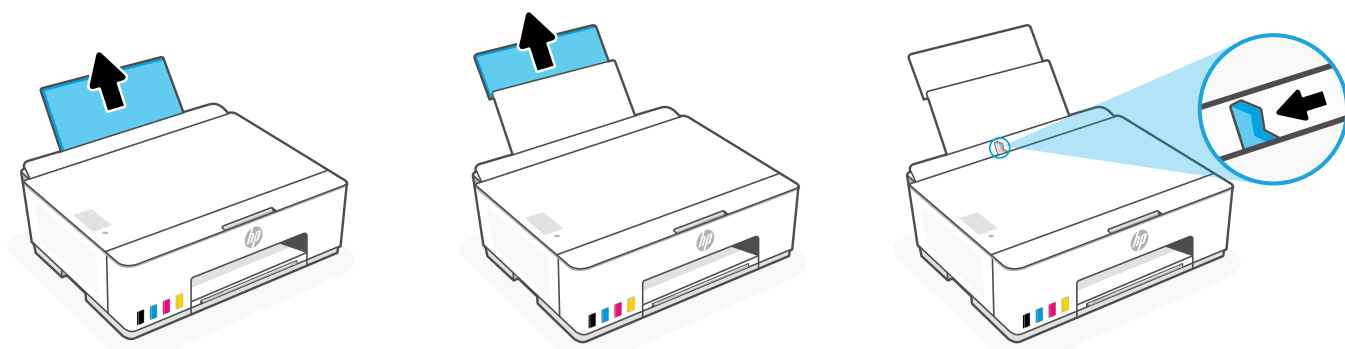

2. 裝入全新未用的 Letter 或 A4 紙張，然後調整紙張導板。打開出紙匣延伸架。



4 安裝 HP Smart 軟體

1. 確認印表機控制台上的 Wi-Fi 指示燈  是否閃爍。若否，請參閱本指南的有關 Wi-Fi 及連線的說明與訣竅一節。
2. 在電腦或行動裝置上，從 123.hp.com 安裝 HP Smart 軟體。

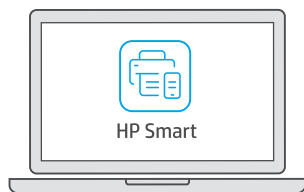

123.hp.com

3. 開啟 HP Smart。若出現提示，請建立或登入 HP 帳戶。
4. 在首頁畫面上，選擇選項以新增印表機，並依照指示將印表機連線到您的網路 (僅支援 2.4 GHz Wi-Fi)。



獲得設定方面的協助

在線上尋找設定資訊及視訊。

hp.com/support/printer-setup



印表機參考

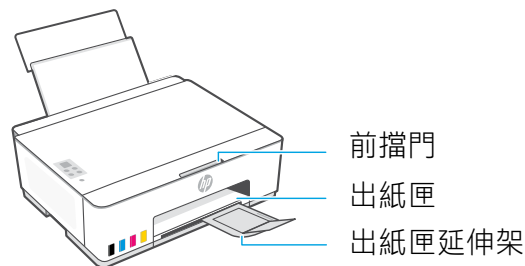
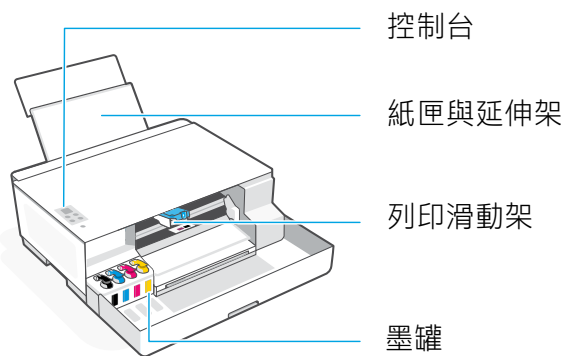

控制台按鈕和指示燈

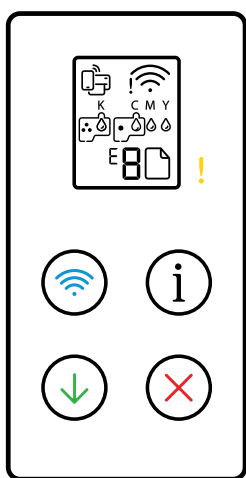

- 電源** 按鈕：開啟或關閉印表機。
- 注意** 指示燈：指示紙張、墨水或列印頭出現問題。
- Wi-Fi** 按鈕/指示燈：開啟或關閉 Wi-Fi。指示燈會指示 Wi-Fi 狀態。
- 資訊** 按鈕：列印印表機設定及狀態的摘要。
- 重新開始** 按鈕：在中斷作業之後重新開始工作。
- 取消** 按鈕：取消目前工作。

控制台顯示器

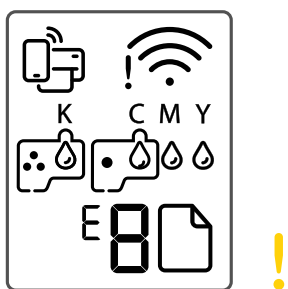



- Wi-Fi Direct 狀態。
 - Wi-Fi 狀態和訊號強度。
 - K C M Y**
墨水相關問題，包括墨水量不足。
 - E1/E2**
紙張大小/長度不相符。
 - E3**
列印滑動架卡住或列印頭蓋板未關閉。
 - E4**
卡紙。
 - E7**
墨水不足。
- 附註：**除非另有指示，否則請勿打開列印頭蓋板。

有關 Wi-Fi 及連線的說明與訣竅

若軟體在設定期間無法找到您的印表機，請檢查下列情況以解決問題。

附註：本印表機僅支援 2.4 GHz Wi-Fi 連線。

可能的問題	解決方案
印表機 Wi-Fi 設定模式逾時 	如果 Wi-Fi 指示燈熄滅，則印表機可能並未處於 Wi-Fi 設定模式。重新啟動 Wi-Fi 設定模式： 1. 按住  5 秒，直到控制台按鈕亮起。 2. 按住  和  5 秒，直到 Wi-Fi 指示燈閃爍藍色。 3. 等待一分鐘。關閉並重新開啟 HP Smart，然後嘗試再次連線。
電腦或行動裝置距離印表機太遠	將您的電腦或行動裝置移至靠近印表機的位置。您的裝置可能不在印表機 Wi-Fi 訊號範圍內。
電腦已連線至 虛擬私人網路 (VPN) 或遠端工作網路	中斷 VPN 連線，然後再安裝 HP Smart 軟體。當連線至 VPN 時，您無法從 Microsoft Store 安裝應用程式。完成印表機設定後，再次連線至 VPN。 附註： 在中斷 VPN 連線前，請考慮您的位置及 Wi-Fi 網路安全性。
您的電腦或行動裝置上的 Bluetooth 已關閉 您的行動裝置上的位置 已關閉	開啟正在使用之電腦或行動裝置的 Bluetooth 以完成印表機設定。針對行動裝置，請一併開啟位置服務。Bluetooth 與位置可協助軟體找到您的網路及印表機。 附註： 我們不會確認您的位置，在設定過程中也不會有位置資訊傳送至 HP。

以妥善安全的方式搬動印表機， 以免墨水濺漏

 hp.com/support/movingsmarttank

1. 關閉印表機，並拔除電源線。

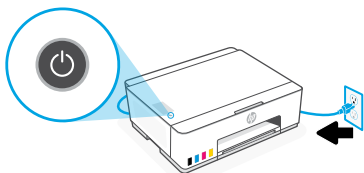

2. 開啟前擋門。確認列印滑動架已移至最左側；
若否，請手動將其移至最左側。

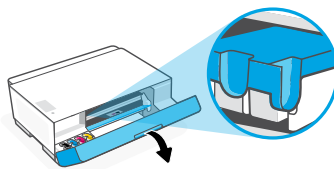

3. 按下列印頭蓋板側邊以將蓋板鬆開。

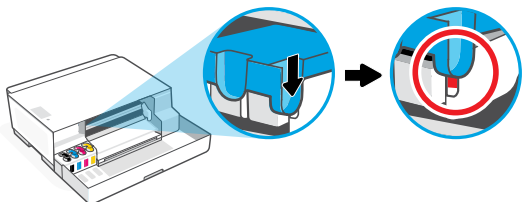

4. 插入固定紙板。關上前擋門。

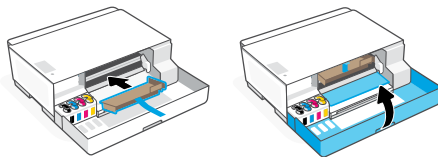

5. 將印表機裝箱 (如果適用)。
搬動印表機時，請使其保持水平，
避免墨水漏出。

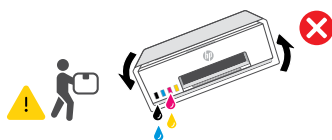

6. 從箱中取出後，按下藍色卡榫以關閉列印頭蓋板。
確定蓋板已妥當關緊。

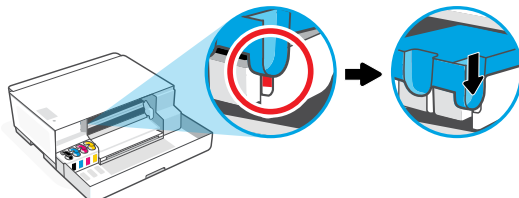

7. 連接電源線，然後開啟印表機電源。

如需印表機疑難排解及視訊等內容，
請造訪 hp.com/support

1 Gỡ bỏ bao bì và bật nguồn

1. Gỡ bỏ tất cả băng keo và vật liệu đóng gói.
Lưu ý: Giữ lại vật liệu đóng gói để đóng gói lại trong trường hợp bạn cần di chuyển máy in.

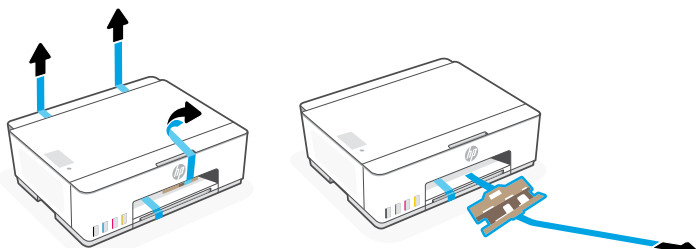

2. Đóng cửa trước.

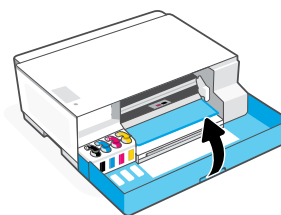

3. Cắm nguồn và bật máy in.
Giữ máy in bật trong quá trình thiết lập.

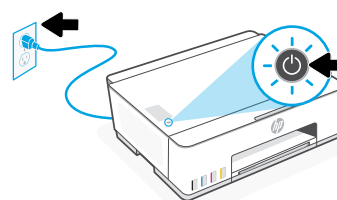
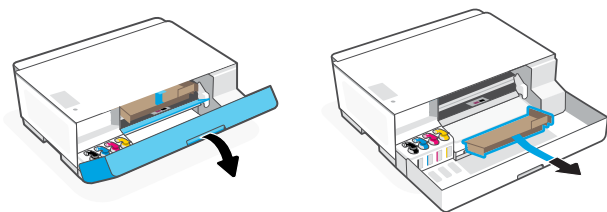

2 Chọn tùy chọn thiết lập máy in

Khuyến dùng

Tùy chọn 1: Thiết lập có hướng dẫn với HP Smart

1. Vào 123.hp.com trên thiết bị di động hoặc máy tính để cài đặt phần mềm HP Smart.

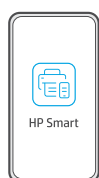

2. Mở **HP Smart**. Nếu được nhắc, hãy tạo hoặc đăng nhập vào tài khoản HP.
3. Trên màn hình chính, chọn tùy chọn thêm máy in và làm theo hướng dẫn để kết nối máy in với mạng (chỉ hỗ trợ Wi-Fi 2,4 GHz).
4. Xem hình ảnh động để nạp mực vào bình mực, lắp đầu in và nạp giấy trong HP Smart. HP Smart có mọi thứ bạn cần để hoàn thành thiết lập.

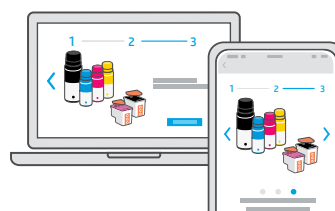
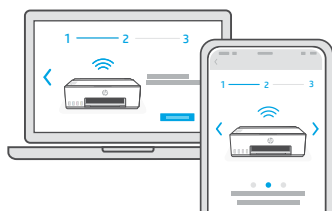

Tùy chọn 2: Thiết lập thủ công



Làm theo hình minh họa trong hướng dẫn này để thiết lập phần cứng, sau đó sử dụng phần mềm HP Smart để kết nối với Wi-Fi và hoàn thành thiết lập.



Thiết lập thủ công

1 Đổ mực vào các bình mực



1. Mở cửa trước.

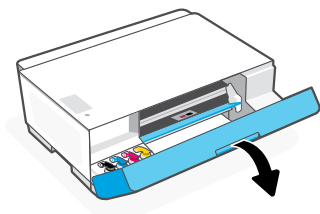

2. Mở nắp bình mực mà bạn muốn đổ mực.

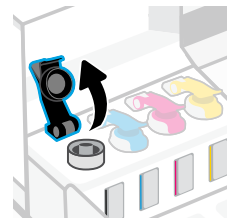

3. Vận nắp để mở chai mực.



4. Lộn ngược chai mực vào bình mực và khớp vào vị trí. Đợi cho đến khi mực đổ đầy bình mực.

Lưu ý: Chai mực đen sẽ vẫn còn mực.

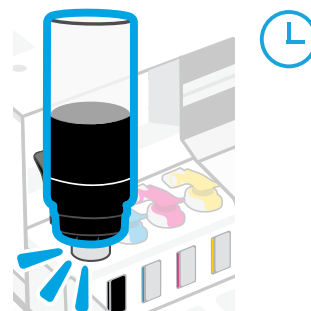

5. Đóng chai mực, ấn mạnh nắp vào chai mực.

Lưu ý: Nếu vẫn còn mực trong chai, hãy đóng chai mực đúng cách và giữ chai thẳng đứng ở nơi tối, mát mẻ.

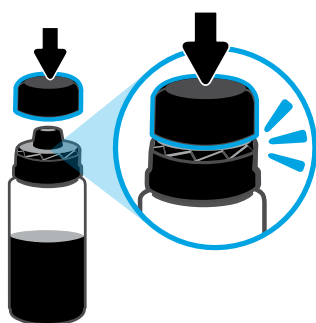

6. Đóng chặt nắp bình mực.

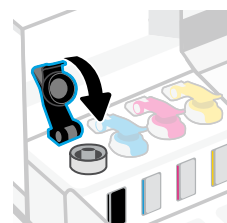

7. Lặp lại việc đổ mực vào tất cả các bình mực.

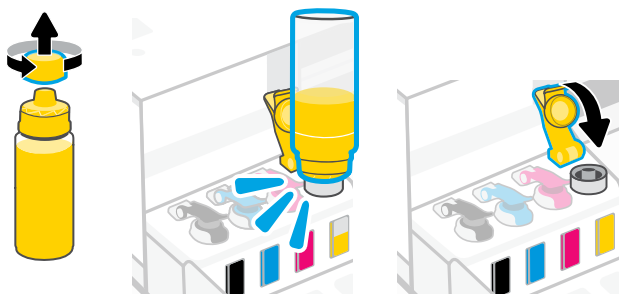

8. Sau khi đổ mực vào tất cả các bình mực, hãy đóng cửa trước.

 Đợi khoảng 15 giây để máy in kiểm tra mực.

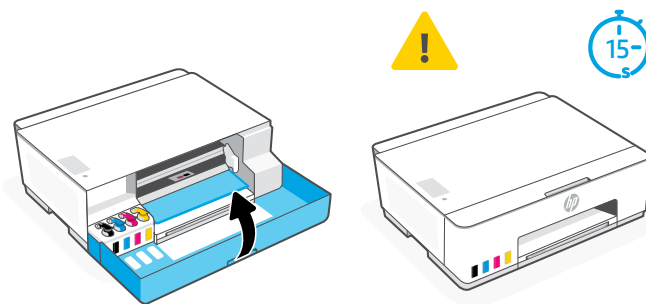

2 Lắp đầu in



! Trước khi lắp đầu in, hãy đảm bảo như sau:

- Máy in đang bật.
- Bạn đã đóng cửa trước trong khoảng 15 giây sau khi đổ mực.

1. Mở cửa trước. Đảm bảo khay giữ đầu in đã di chuyển đến chính giữa; nếu không, hãy đóng cửa trong 15 giây.

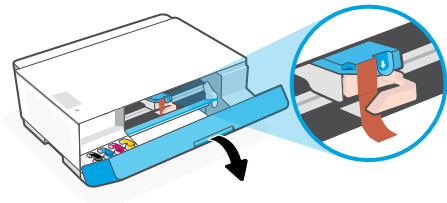

2. Gỡ bỏ băng keo màu cam khỏi nắp đầu in. Nhấn và nhả chốt màu xanh lam để mở nắp đầu in.

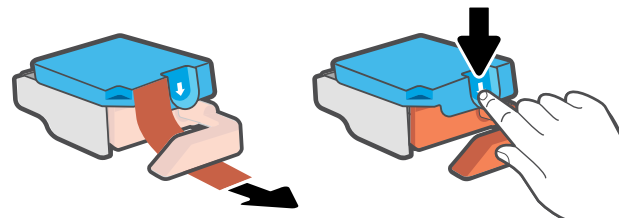

3. Tháo và loại bỏ miếng bảo vệ màu cam.

Lưu ý: Giữ miếng bảo vệ thẳng đứng; cầm cẩn thận để tránh rò rỉ mực.

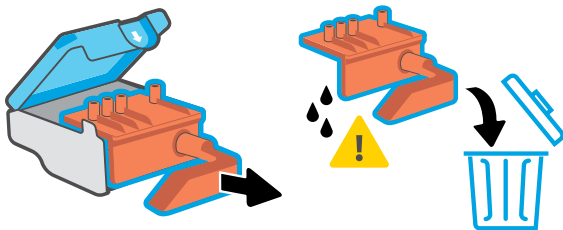

4. Tháo nắp và băng keo màu cam ra khỏi cả hai đầu in.

Thận trọng: Không chạm vào các tiếp điểm điện hoặc vòi in bên dưới băng keo.

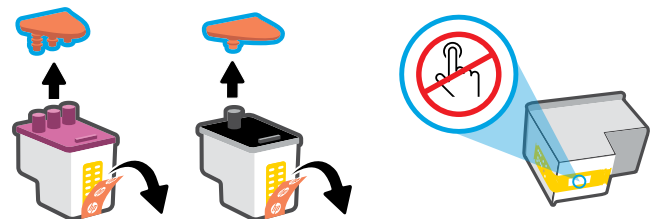

5. Lắp đầu in và khớp vào vị trí. Lắp lại thao tác lắp đầu in còn lại.

Lưu ý: Đảm bảo rằng các tiếp điểm điện hướng vào bên trong.

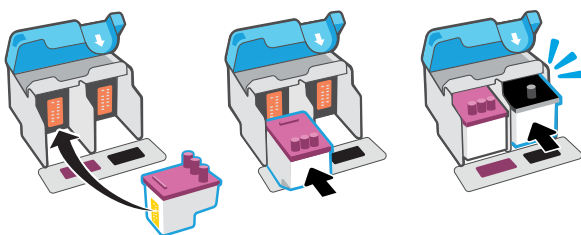

6. Đóng nắp đầu in và cửa trước.

Lưu ý: Đảm bảo rằng nắp đầu in được đóng đúng cách.

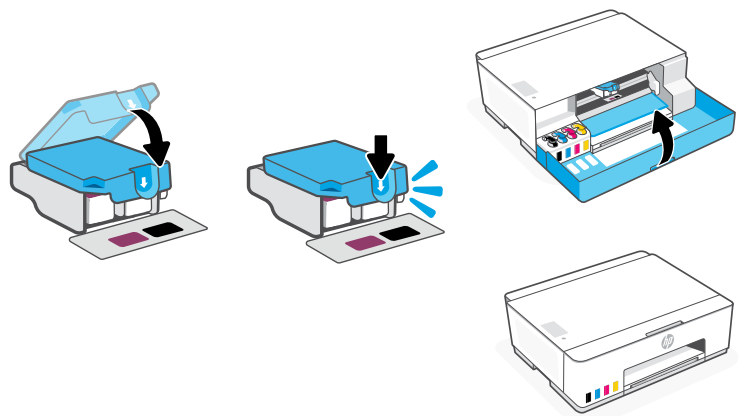

3 Nạp giấy

1. Kéo khay giấy và phần mở rộng lên, sau đó trượt thanh dẫn hướng giấy sang bên trái.

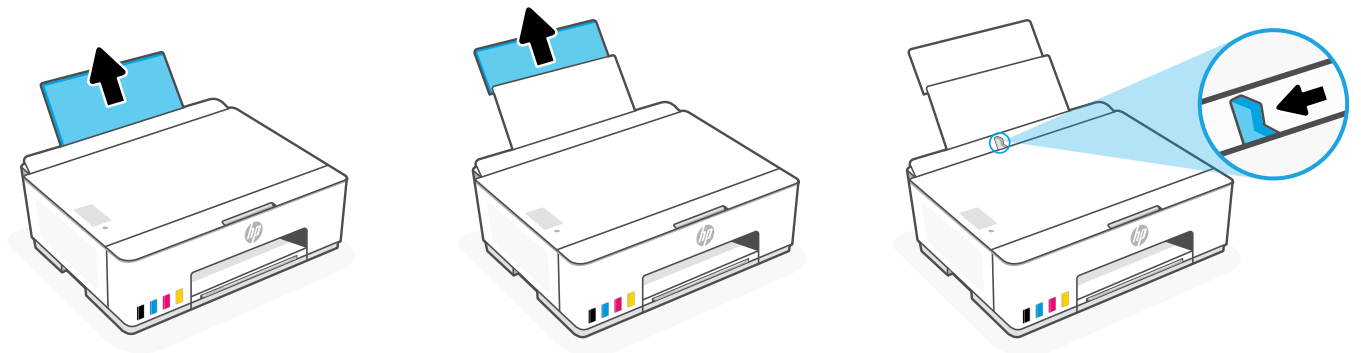

2. Nạp giấy Letter hoặc A4 mới, chưa sử dụng và điều chỉnh thanh dẫn hướng giấy. Mở phần mở rộng khay giấy ra.

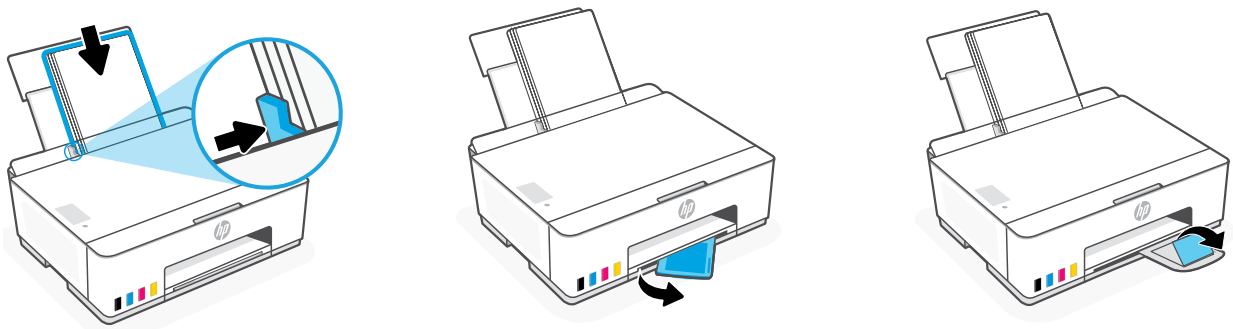

4 Cài đặt phần mềm HP Smart

1. Đảm bảo rằng đèn **Wi-Fi**  trên bảng điều khiển máy in nhấp nháy. Nếu không, hãy xem phần **Trợ giúp và mẹo về Wi-Fi và kết nối** trong hướng dẫn này.
2. Cài đặt phần mềm HP Smart từ **123.hp.com** trên máy tính hoặc thiết bị di động.

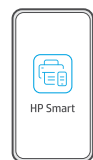
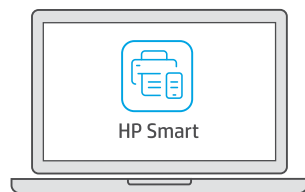

123.hp.com

3. Mở **HP Smart**. Nếu được nhắc, hãy tạo hoặc đăng nhập vào tài khoản HP.
4. Trên màn hình chính, chọn tùy chọn thêm máy in và làm theo hướng dẫn để kết nối máy in với mạng (chỉ hỗ trợ Wi-Fi 2,4 GHz).



Nhận trợ giúp liên quan đến cài đặt
Tìm thông tin cài đặt và video trực tuyến.
hp.com/support/printer-setup



Tham khám máy in

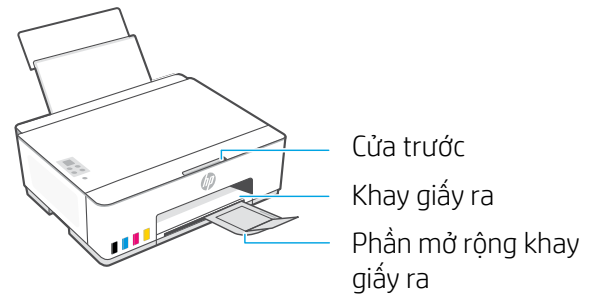
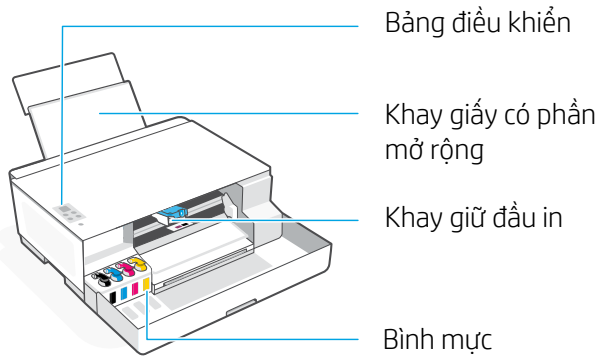

Các nút và đèn trên điều khiển

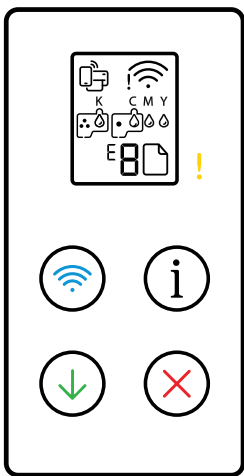

- Nút Nguồn:** Bật hoặc tắt máy in.
- Đèn Cảnh báo:** Cho biết có vấn đề với giấy, mực hoặc đầu in.
- Nút/đèn Wi-Fi:** Bật hoặc tắt Wi-Fi. Đèn cho biết trạng thái Wi-Fi.
- Nút Thông tin:** In tóm tắt cài đặt và trạng thái máy in.
- Nút Tiếp tục:** Tiếp tục công việc sau khi gián đoạn.
- Nút Hủy:** Hủy công việc hiện tại.

Màn hình bảng điều khiển

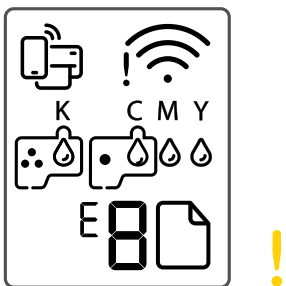

Trạng thái Wi-Fi Direct.

Trạng thái Wi-Fi và cường độ tín hiệu.

K C M Y
!

Vấn đề liên quan đến mực, bao gồm gần hết mực.

!

Vấn đề liên quan đến đầu in.

Lưu ý: Không mở nắp đầu in trừ khi được hướng dẫn.

Vấn đề liên quan đến vật liệu in, bao gồm cả hết giấy.

E1/E2

Kích cỡ/chiều dài giấy không khớp với nhau.

E3

Khung vận chuyển đầu in bị kẹt hoặc nắp đầu in chưa đóng.

E4

Kẹt giấy.

E7

Hết mực.

Trợ giúp và mẹo về Wi-Fi và kết nối

Nếu phần mềm không thể tìm thấy máy in của bạn trong quá trình thiết lập, hãy kiểm tra các điều kiện sau đây để xử lý sự cố.

Lưu ý: Máy in này chỉ hỗ trợ kết nối Wi-Fi 2,4 GHz.



Sự cố có thể xảy ra

Giải pháp

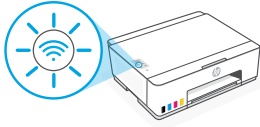
Đã hết thời gian chờ chế độ thiết lập Wi-Fi máy in



Nếu đèn Wi-Fi tắt, máy in có thể không ở chế độ thiết lập Wi-Fi. Khởi động lại chế độ thiết lập Wi-Fi:

1. Nhấn và giữ  trong 5 giây cho đến khi các nút trên bảng điều khiển sáng lên.
2. Nhấn và giữ  và  trong 5 giây cho đến khi đèn Wi-Fi nhấp nháy màu xanh lam.
3. Đợi một phút. Đóng và mở lại HP Smart, sau đó thử kết nối lại.

Máy tính hoặc thiết bị di động ở quá xa máy in

Di chuyển máy tính hoặc thiết bị di động lại gần máy in hơn. Có thể thiết bị của bạn ở ngoài phạm vi sóng Wi-Fi của máy in.

Máy tính đã kết nối với Mạng Riêng Ảo (VPN) hoặc mạng làm việc từ xa

Ngắt kết nối khỏi VPN trước khi cài đặt phần mềm HP Smart. Bạn không thể cài đặt ứng dụng từ Microsoft Store khi đang kết nối với VPN. Kết nối lại với VPN sau khi hoàn thành thiết lập máy in.

Lưu ý: Hãy xem xét vị trí của bạn và bảo mật của mạng Wi-Fi trước khi ngắt kết nối khỏi VPN.

Bluetooth đã tắt trên máy tính và thiết bị di động của bạn
Vị trí đã tắt trên thiết bị di động của bạn

Tắt Bluetooth cho máy tính và thiết bị di động đang được sử dụng để thiết lập máy in. Tắt cả dịch vụ Vị trí trên thiết bị di động. Bluetooth và Vị trí giúp phần mềm tìm mạng và máy in của bạn.

Lưu ý: Vị trí của bạn hiện không được xác định và không có thông tin vị trí nào được gửi cho HP trong quy trình thiết lập.

Di chuyển máy in đúng cách để tránh rò rỉ mực

 hp.com/support/movingsmarttank

1. Tắt máy in và rút dây nguồn.

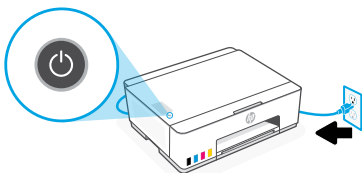

3. Nhấn xuống ở bên cạnh nắp đầu in để nhả nắp.

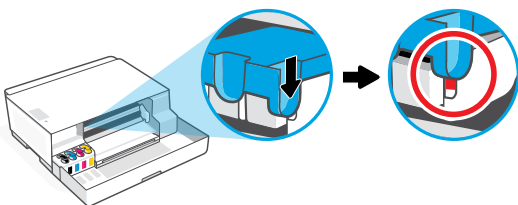

5. Đóng gói máy in vào hộp (nếu có).
Trong khi di chuyển máy in, hãy giữ máy in nằm ngang để tránh rò rỉ mực.

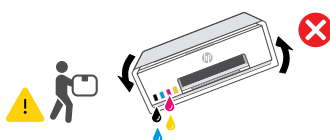

7. Kết nối dây nguồn và bật máy in.

2. Mở cửa trước. Đảm bảo rằng khay giữ đầu in ở tận cùng phía bên trái; nếu không, hãy di chuyển bằng tay sang bên trái.

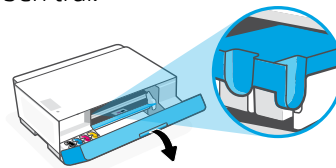

4. Chèn tấm giữ bằng bìa cứng. Đóng cửa trước.

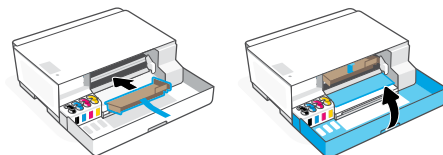

6. Sau khi mở hộp, nhấn chốt màu xanh lam xuống để đóng nắp đầu in. Đảm bảo rằng nắp được đóng đúng cách.

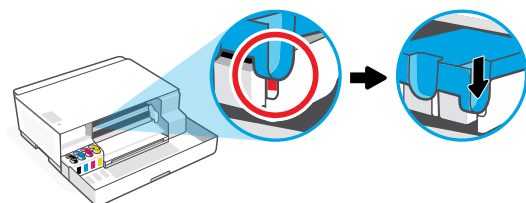

Để biết cách khắc phục sự cố máy in và video, vui lòng truy cập hp.com/support

1 Buka kemasan dan nyalakan

1. Lepas semua pita perekat dan bahan pembungkus.

Catatan: Simpan kemasan untuk pengemasan ulang jika Anda perlu memindahkan printer.

2. Tutup pintu depan.

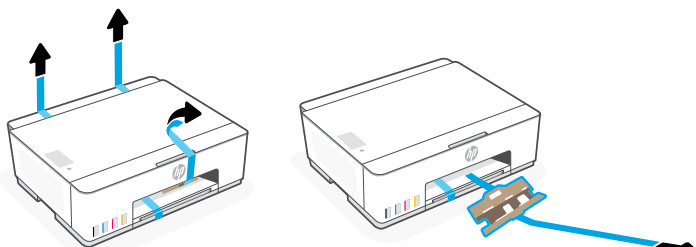
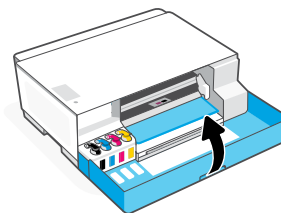

3. Colokkan dan nyalakan printer. Jangan matikan printer selama persiapan.

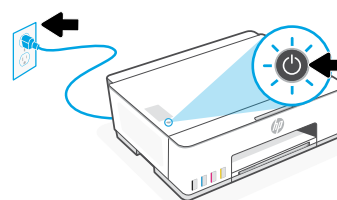
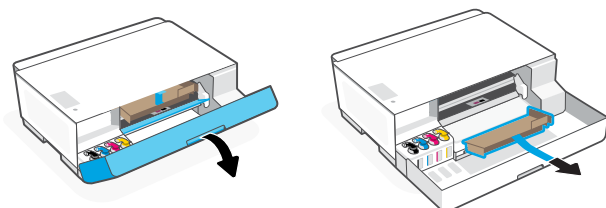

2 Pilih opsi untuk menyiapkan printer

Dianjurkan

Opsi 1: Penyiapan terpandu dengan HP Smart

1. Buka 123.hp.com pada perangkat seluler atau komputer untuk menginstal perangkat lunak HP Smart.

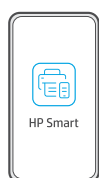

2. Buka **HP Smart**. Jika diminta, buat atau masuk ke akun HP.
3. Pada layar Beranda, pilih opsi untuk menambahkan printer, dan ikuti petunjuk untuk menghubungkan printer ke jaringan (hanya Wi-Fi 2,4 GHz yang didukung).
4. Lihat animasi untuk mengisi tangki tinta, memasang kepala cetak, dan memasukkan kertas di HP Smart. HP Smart menyediakan semua yang Anda butuhkan untuk menyelesaikan penyiapan.

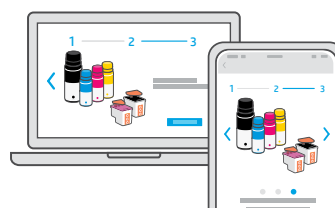
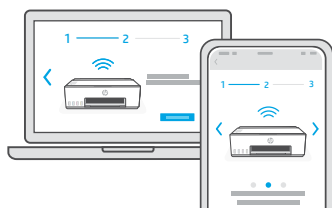

Opsi 2: Penyiapan manual



Ikuti ilustrasi dalam panduan ini untuk menyiapkan perangkat keras, lalu gunakan perangkat lunak HP Smart untuk menghubungkan ke Wi-Fi dan menyelesaikan penyiapan.



Penyiapan Manual

1 Isi tangki tinta



1. Buka pintu depan.

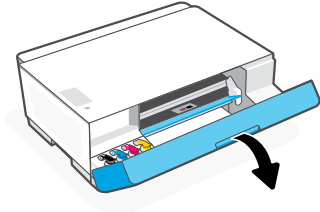

2. Buka tutup tangki tinta yang ingin Anda isi ulang.

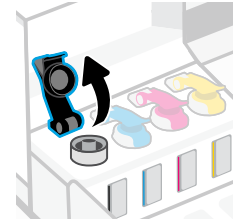

3. Putar botol tinta sampai terbuka.



4. Tempatkan botol dalam posisi terbalik ke tangki dan pasang sampai pas. Tunggu sampai tangki terisi tinta.

Catatan: Sisa tinta akan menempel pada botol hitam.

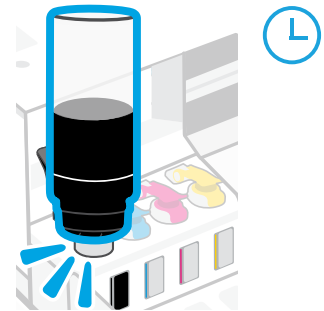

5. Tutup botol tinta, dengan menekan kuat tutupnya ke dalam botol.

Catatan: Jika terdapat sisa tinta di dalam botol, tutup botol dengan benar dan simpan botol dalam posisi tegak lurus di tempat yang sejuk dan gelap.

6. Tutup penutup tangki dengan aman.

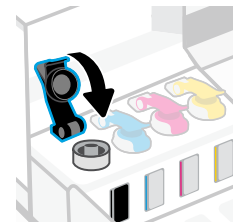
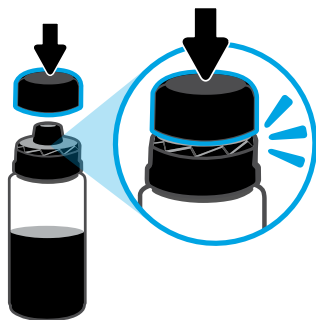

7. Ulangi untuk mengisi semua tangki.

8. Setelah semua tangki terisi, tutup pintu depan.

 Tunggu sekitar 15 detik sampai printer memeriksa tinta.

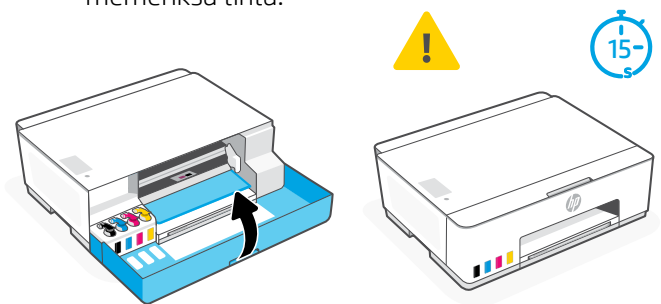
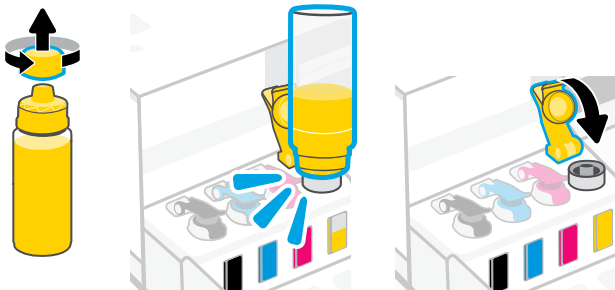

2 Memasang kepala cetak



Sebelum memasang kepala cetak, pastikan:

- Printer menyala.
- Keempat tangki tinta terisi.
- Anda telah menutup pintu depan selama sekitar 15 detik setelah mengisi tinta.

1. Buka pintu depan. Pastikan kereta cetak telah pindah ke tengah; jika tidak, tutup pintu selama 15 detik.

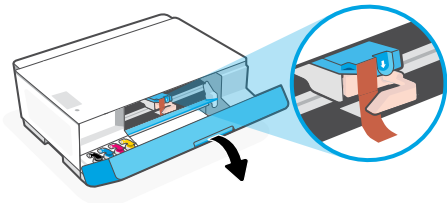

2. Lepas pita oranye dari penutup kepala cetak. Tekan dan lepaskan selot biru untuk membuka penutup kepala cetak.

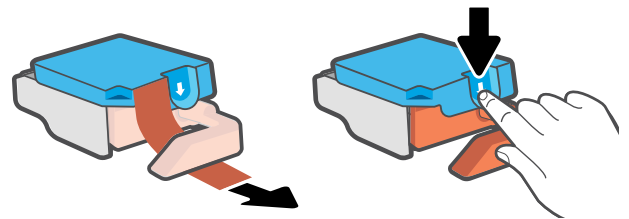

3. Lepas dan buang pelindung oranye.

Catatan: Pastikan pelindung dalam posisi tegak lurus; pegang dengan hati-hati agar tinta tidak bocor.

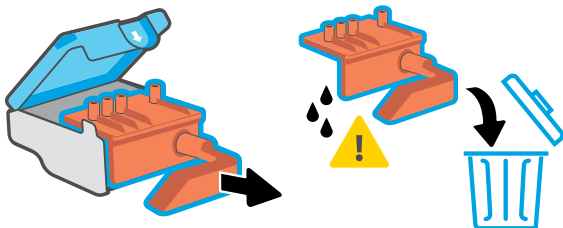

4. Lepas tutup dan pita oranye dari kedua kepala cetak.

Perhatian: Jangan sentuh kontak listrik atau nozel cetak di bawah pita perekat.

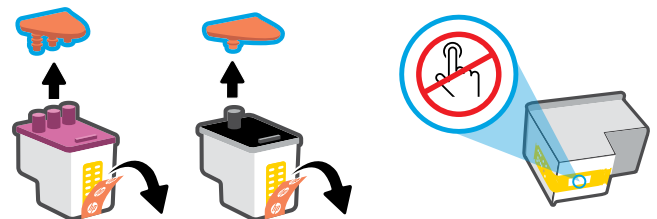

5. Masukkan kepala cetak dan pasang sampai pas. Ulangi untuk memasang kepala cetak lainnya.

Catatan: Pastikan kontak listrik menghadap ke dalam.

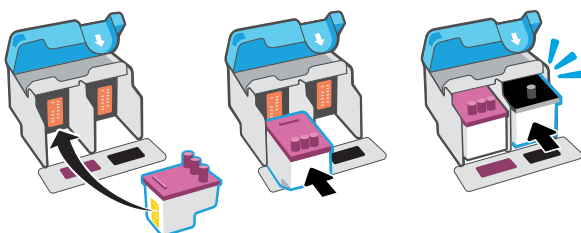

6. Tutup penutup kepala cetak dan pintu depan.

Catatan: Pastikan penutup kepala cetak ditutup dengan benar.

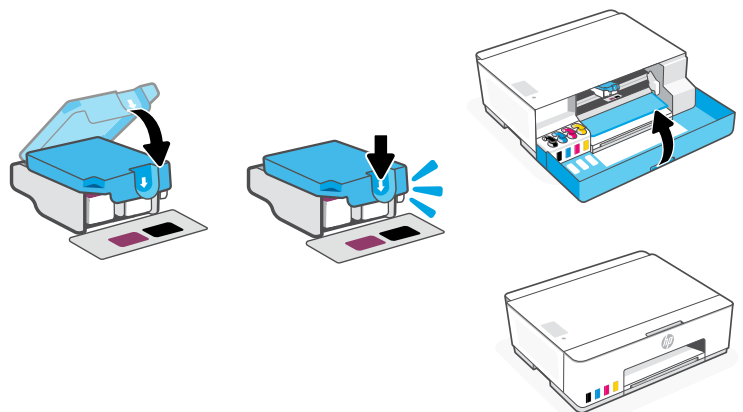

3 Memasukkan kertas

1. Tarik baki kertas dan pemanjang, dan geser pemandu kertas ke kiri.

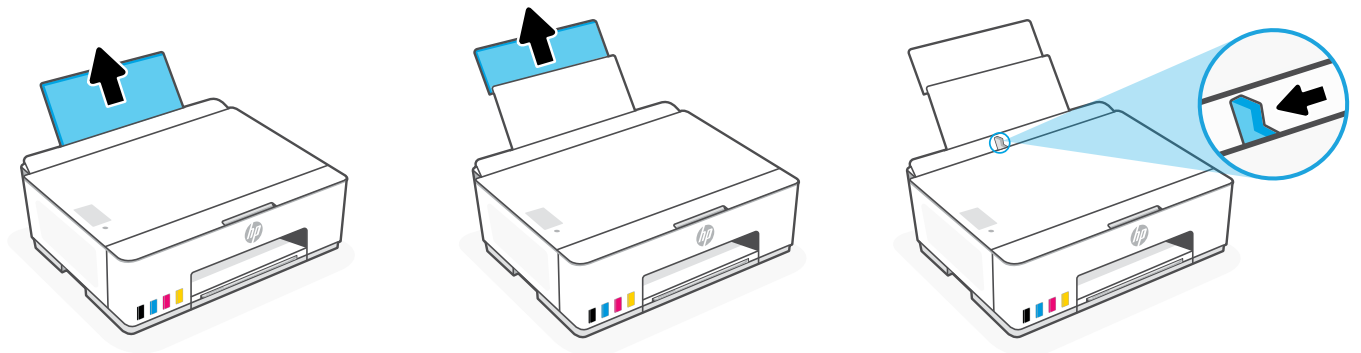

2. Masukkan kertas Letter atau A4 baru atau yang belum dipakai dan sesuaikan pemandu kertas. Buka pemanjang baki keluaran.

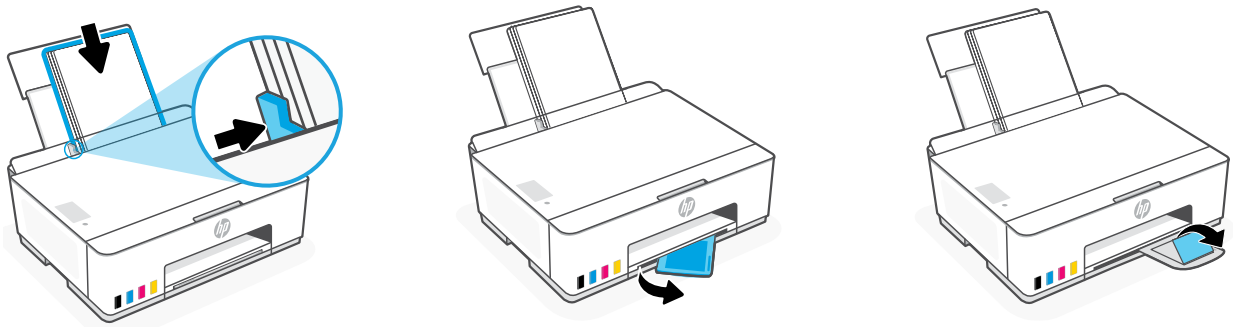

4 Instal perangkat lunak HP Smart

1. Pastikan lampu **Wi-Fi**  pada panel kontrol printer berkedip. Jika tidak, lihat bagian **Bantuan dan kiat untuk Wi-Fi dan konektivitas** dalam panduan ini.
2. Instal perangkat lunak HP Smart dari **123.hp.com** di komputer atau perangkat seluler.

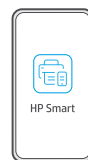
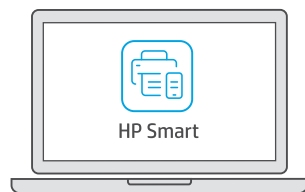

123.hp.com

3. Buka **HP Smart**. Jika diminta, buat atau masuk ke akun HP.
4. Pada layar Beranda, pilih opsi untuk menambahkan printer, dan ikuti petunjuk untuk menghubungkan printer ke jaringan (hanya Wi-Fi 2,4 GHz yang didukung).



Dapatkan bantuan penyiapan

Temukan informasi penyiapan dan video secara online.

hp.com/support/printer-setup



Referensi Printer

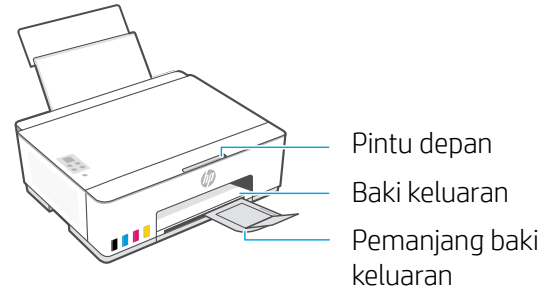
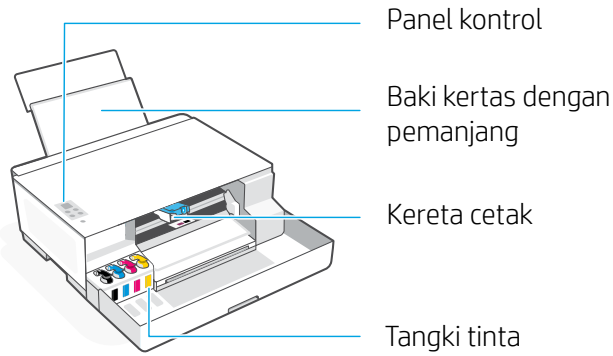

Tombol dan lampu panel kontrol

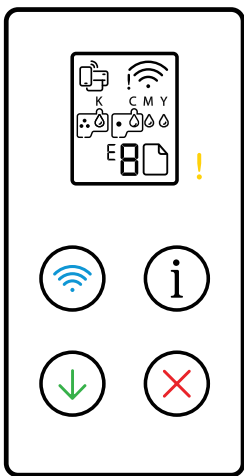

- Tombol **Daya**: Menyalakan atau mematikan printer.
- Lampu **Perhatian**: Menunjukkan masalah pada kertas, tinta, atau kepala cetak.
- Tombol/lampu **Wi-Fi**: Mengaktifkan atau menonaktifkan Wi-Fi. Lampu menunjukkan status Wi-Fi.
- Tombol **Informasi**: Mencetak ringkasan pengaturan dan status printer.
- Tombol **Lanjut**: Melanjutkan tugas setelah gangguan.
- Tombol **Batal**: Batalan tugas yang sedang berjalan.

Layar panel kontrol

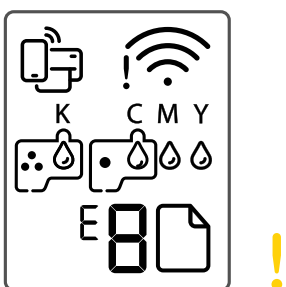

Status Wi-Fi Direct.

Status Wi-Fi dan kekuatan sinyal.

K C M Y
Masalah terkait tinta, termasuk tinta hampir habis.

Masalah terkait kepala cetak.

Catatan: Jangan buka penutup kepala cetak, kecuali jika diperintahkan.

Masalah terkait media, termasuk kehabisan kertas.

E1/E2
Ukuran/panjang kertas tidak sesuai.

E3
Kereta cetak macet atau penutup kepala cetak belum ditutup.

E4
Kertas macet.

E7
Tinta habis.

Bantuan dan kiat untuk Wi-Fi dan konektivitas

Jika perangkat lunak tidak dapat menemukan printer Anda selama penyiapan, periksa kondisi berikut untuk menyelesaikan masalah.

Catatan: Printer ini hanya mendukung koneksi Wi-Fi 2,4 GHz.

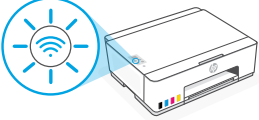
Kemungkinan Masalah	Solusi
<p>Waktu mode penyiapan Wi-Fi printer telah habis</p> 	<p>Jika lampu Wi-Fi mati, printer mungkin tidak dalam mode penyiapan Wi-Fi. Mulai ulang mode penyiapan Wi-Fi:</p> <ol style="list-style-type: none">1. Tekan dan tahan ⓘ selama 5 detik sampai tombol panel kontrol menyala.2. Tekan dan tahan ⓘ dan ✗ selama 5 detik sampai lampu Wi-Fi berkedip biru.3. Tunggu selama satu menit. Tutup, lalu buka kembali HP Smart, lalu coba hubungkan kembali.
<p>Komputer atau perangkat seluler terlalu jauh dari printer</p>	<p>Dekatkan komputer atau perangkat seluler Anda ke printer. Perangkat Anda mungkin berada di luar jangkauan sinyal Wi-Fi printer.</p>
<p>Komputer terhubung ke Virtual Private Network (VPN) atau jaringan kerja jarak jauh</p>	<p>Putus koneksi dari VPN sebelum menginstal perangkat lunak HP Smart. Anda tidak dapat menginstal aplikasi dari Microsoft Store saat terhubung ke VPN. Hubungkan kembali ke VPN setelah penyiapan printer selesai.</p> <p>Catatan: Pertimbangkan lokasi Anda dan keamanan jaringan Wi-Fi sebelum memutuskan koneksi dari VPN.</p>
<p>Bluetooth dinonaktifkan di komputer atau perangkat seluler Anda</p> <p>Lokasi dinonaktifkan di perangkat seluler Anda</p>	<p>Aktifkan Bluetooth untuk komputer atau perangkat seluler yang digunakan untuk menyelesaikan penyiapan printer. Untuk perangkat seluler, aktifkan juga layanan Lokasi. Bluetooth dan Lokasi membantu perangkat lunak menemukan jaringan dan printer Anda.</p> <p>Catatan: Lokasi Anda belum ditetapkan dan tidak ada informasi lokasi yang dikirimkan ke HP sebagai bagian dari proses penyiapan.</p>

Memindahkan printer dengan benar untuk mencegah kebocoran tinta

 hp.com/support/movingsmarttank

1. Matikan printer dan cabut kabel dayanya.

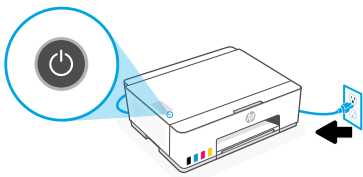

2. Buka pintu depan. Pastikan kereta cetak mengarah ke kiri sepenuhnya; jika tidak, pindahkan ke kiri secara manual.

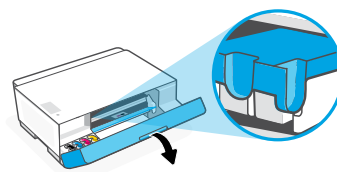

3. Tekan sisi penutup kepala cetak ke bawah untuk melepaskan penutup.

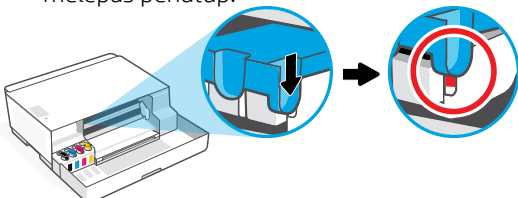

4. Masukkan karton penahan. Tutup pintu depan.

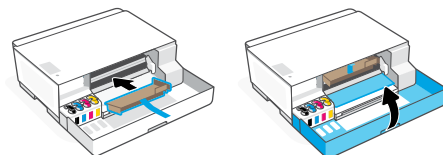

5. Masukkan printer ke dalam kotak kemasan (jika ada). Saat memindahkan printer, pertahankan printer dalam posisi horizontal untuk mencegah kebocoran tinta.



6. Setelah membuka kemasan, tekan selot biru untuk menutup penutup kepala cetak. Pastikan penutup tertutup dengan benar.

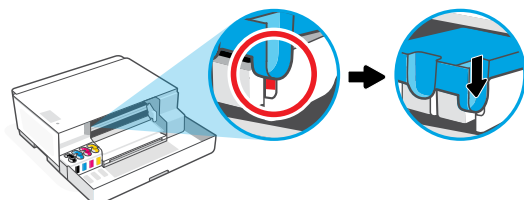

7. Colokkan kabel daya, kemudian nyalakan printer.

Untuk pemecahan masalah dan video tentang printer, kunjungi hp.com/support

Informasi Importir

PT. Hewlett Packard Indonesia Gedung Perkantoran Prudential Center Kota Kasablanka Lantai 9, Jl. Casablanca Kav.88 Kel. Menteng Dalam, Kec. Tebet, Kota Administrasi Jakarta Selatan 12870

- HP Smart Tank 210
- HP Smart Tank 215

Petunjuk Pemeliharaan

Lakukan prosedur pencegahan dasar setiap kali hendak menggunakan printer ini untuk mengurangi resiko cedera karena terbakar atau sengatan listrik:

1. Bacalah dan pahami seluruh petunjuk dalam dokumentasi yang menyertai printer.
2. Perhatikan semua tanda peringatan dan petunjuk yang tertera pada printer.
3. Cabut kabel printer dari stopkontak sebelum membersihkan.
4. Jangan memasang atau menggunakan printer ini dekat air atau saat Anda basah.
5. Letakkan printer dengan benar pada permukaan yang stabil.
6. Letakkan printer di lokasi yang aman dimana tak seorangpun dapat menginjak atau tersangkut kabel daya, dan agar kabel daya tidak rusak.
7. Tidak ada komponen bagian dalam yang dapat diperbaiki pengguna. Serahkan perbaikan kepada petugas servis resmi.
8. Gunakan hanya dengan kabel daya dan adaptor daya yang disediakan HP.



© Copyright 2023 HP Development Company, L.P.

Microsoft is a registered trademark of Microsoft Corporation in the United States and/or other countries.
All third party trademarks are the property of their respective owners

Printed in China

EN

TH

ZHTW

VI

ID



3D4L3-90016