HP Notebook PC

Reference Guide

Notice

This manual and any examples contained herein are provided “as is” and are subject to change without notice. Hewlett-Packard Company makes no warranty of any kind with regard to this manual, including, but not limited to, the implied warranties of merchantability and fitness for a particular purpose. Hewlett-Packard Co. shall not be liable for any errors or for incidental or consequential damages in connection with the furnishing, performance, or use of this manual or the examples herein.

Consumer transactions in Australia and the United Kingdom: The above disclaimers and limitations shall not apply to Consumer transactions in Australia and the United Kingdom and shall not affect the statutory rights of Consumers.

© Copyright Hewlett-Packard Company 2000–2001. All rights reserved. Reproduction, adaptation, or translation of this manual is prohibited without prior written permission of Hewlett-Packard Company, except as allowed under the copyright laws.

The programs that control this product are copyrighted and all rights are reserved. Reproduction, adaptation, or translation of those programs without prior written permission of Hewlett-Packard Co. is also prohibited.

Portions of the programs that control this product may also be copyrighted by Microsoft Corporation, Insyde Systems, Conexant Systems Incorporated, VIA Technologies Incorporated, ALPS Electric (USA) Incorporated, and Adobe Systems Incorporated. See the individual programs for additional copyright notices.

Microsoft®, MS-DOS®, and Windows® are U.S. registered trademarks of Microsoft Corporation. TrackPoint™ is a U.S. trademark of International Business Machines. Adobe® and Acrobat® are trademarks of Adobe Systems Incorporated.

Hewlett-Packard Company
HP Notebook Customer Care
1070 NE Circle Blvd., MS 425E
Corvallis, OR 97330, U.S.A.

Important safety information

CAUTION

To reduce the risk of fire, use only No. 26 AWG or larger telecommunications line cord to connect the modem to the telephone wall jack.

When using your notebook with a telephone connection, always follow basic safety precautions to reduce the risk of fire, electric shock, and injury to persons:

- Do not use this product with a telephone connection near water, for example, near a bathtub, sink, swimming pool, or in a wet basement.
- Avoid using a telephone connection (other than a cordless type) during an electrical storm. There may be a remote risk of electric shock from lightning.
- Do not use a telephone connection of any type to report a gas leak while in the vicinity of the leak.
- Use only the power cord and batteries indicated in this manual. Do not dispose of batteries in a fire. They may explode. Check with local codes for possible special disposal instructions.

HP Software Product License Agreement

Your HP product contains software programs. CAREFULLY READ THIS LICENSE AGREEMENT BEFORE PROCEEDING TO OPERATE THIS EQUIPMENT. RIGHTS IN THE SOFTWARE ARE OFFERED ONLY ON THE CONDITION THAT THE CUSTOMER AGREES TO ALL TERMS AND CONDITIONS OF THE LICENSE AGREEMENT. PROCEEDING TO OPERATE THE EQUIPMENT INDICATES YOUR ACCEPTANCE OF THESE TERMS AND CONDITIONS. IF YOU DO NOT AGREE WITH THE TERMS OF THE LICENSE AGREEMENT, YOU MUST NOW EITHER REMOVE THE SOFTWARE FROM YOUR HARD DISK DRIVE AND DESTROY THE MASTER DISKETTES, OR RETURN THE COMPLETE HP PRODUCT AND SOFTWARE FOR A FULL REFUND. PROCEEDING WITH CONFIGURATION SIGNIFIES YOUR ACCEPTANCE OF THE LICENSE TERMS.

UNLESS OTHERWISE STATED BELOW, THIS HP SOFTWARE LICENSE AGREEMENT SHALL GOVERN THE USE OF ALL SOFTWARE THAT IS PROVIDED TO YOU AS PART OF THE HP PRODUCT AND SHALL SUPERSEDE ANY OTHER SOFTWARE WARRANTY STATEMENT THAT MAY BE INCLUDED IN THIS HP PRODUCT OR MAY BE FOUND ONLINE.

Operating system and software applications by Microsoft are licensed to you under the Microsoft License Agreement contained in the Microsoft documentation or displayed on your screen when Microsoft Software Products are launched.

For a PC supplied with a Microsoft operating system: When you start the PC and accept the Microsoft End-user License Agreement (“EULA”), your license rights are valid only if a Certificate of Authenticity (“COA”) label corresponding to your Microsoft operating system is provided with your PC. The COA label can usually be found on the bottom of the computer. If the COA label does not correspond to your Microsoft operating system or is missing, contact your HP reseller for details.

Other non-HP Software and Operating Systems are covered by the appropriate vendor license. The following License Terms govern the use of the HP software:

USE. Customer may use the software on any one HP product. Customer may not network the software or otherwise use it on more than one HP product. Customer may not reverse assemble or decompile the software unless authorized by law.

COPIES AND ADAPTATIONS. Customer may make copies or adaptations of the software a) for archival purposes or (b) when copying or adaptation is an essential step in the use of the software with an HP product so long as the copies and adaptations are used in no other manner.

OWNERSHIP. Customer agrees that he/she does not have any title or ownership of the software, other than ownership of the physical media. Customer acknowledges and agrees that the software is copyrighted and protected under the copyright laws. Customer acknowledges and agrees that the software may have been developed by a third party software supplier named in the copyright notices included with the software, who shall be authorized to hold the Customer responsible for any copyright infringement or violation of this Agreement.

PRODUCT RECOVERY CD-ROM. If your HP product was shipped with a product recovery CD-ROM: (i) The product recovery CD-ROM and/or support utility software may only be used for restoring the hard disk of the HP product with which the product recovery CD-ROM was originally provided. (ii) The use of any operating system software by Microsoft contained in any such product recovery CD-ROM shall be governed by the Microsoft License Agreement.

TRANSFER OF RIGHTS IN SOFTWARE. Customer may transfer rights in the software to a third party only as part of the transfer of all rights and only if Customer obtains the prior agreement of the third party to be bound by the terms of this License Agreement. Upon such a transfer, Customer agrees that his/her rights in the software are terminated and that he/she will either destroy his/her copies and adaptations or deliver them to the third party.

SUBLICENSING AND DISTRIBUTION. Customer may not lease, sublicense the software or distribute copies or adaptations of the software to the public in physical media or by telecommunication without the prior written consent of Hewlett-Packard.

TERMINATION. Hewlett-Packard may terminate this software license for failure to comply with any of these terms provided Hewlett-Packard has requested Customer to cure the failure and Customer has failed to do so within thirty (30) days of such notice.

UPDATES AND UPGRADES. Customer agrees that the software does not include updates and upgrades which may be available from Hewlett-Packard under a separate support agreement.

EXPORT CLAUSE. Customer agrees not to export or re-export the software or any copy or adaptation in violation of the U.S. Export Administration regulations or other applicable regulation.

U.S. GOVERNMENT RESTRICTED RIGHTS. Use, duplication, or disclosure is subject to HP standard commercial license terms and for non-DOD Departments and Agencies of the U.S. Government, the restrictions set forth in FAR 52.227-19(c)(1-2) (June 1987) Hewlett-Packard Company, 3000 Hanover Street, Palo Alto, CA 94304 U.S.A. Copyright (c) 2000–2001 Hewlett-Packard Company. All Rights Reserved. Customer further agrees that Software is delivered and licensed as “Commercial computer software” as defined in DFARS 252-227-7014 (June 1995) or as a “commercial item” as defined in FAR 2.101(a), or as “Restricted computer software” as defined in FAR 52.227-19 (or any equivalent agency regulation or contract clause), whichever is applicable. The Customer agrees that it has only those rights provided for such Software by the applicable FAR or DFARS clause or the HP standard software agreement for the product involved.

Support Policy for Support Pack of Operating Systems. HP provides end user support for HP PCs that use Microsoft Operating Systems, including its latest service packs. This support will be available within 30 days of the software being released.

Edition History

Edition 1	January 2002
Edition 2	March 2002
Edition 3	June 2002



This manual is printed on recycled paper.

Contents

Important safety information	3
Getting Started with Your HP Notebook.....	11
HP Notebook <i>Reference Guide</i>	Error! Bookmark not defined.
Taking Inventory	12
What's in the box?.....	12
To buy accessories.....	13
To find more information	13
Identifying Parts of the Notebook	15
Front view.....	15
Back view	16
Bottom view	17
Status lights	18
Setting Up Your Notebook.....	20
Step 1: Install the battery	20
Step 2: Connect AC power	22
Step 3: Connect a phone line	23
Step 4: Turn on the notebook	24
Step 5: Set up Windows.....	24
Step 6: Register your notebook.....	25
To connect to the Internet.....	25
Basic Operation.....	27
Operating Your Notebook.....	28
To turn the notebook on and off	28
To reset your notebook.....	29
To change the boot device.....	30
To use the touch pad.....	30
To use the Fn hot keys.....	31
To use the One-Touch buttons.....	32
To use the Windows and Applications keys	34
To use the embedded keypad.....	34
To adjust the display.....	35
To adjust the volume	36
To insert or remove a CD or DVD	36
To play DVD movies.....	38
To create or copy CDs.....	39
Securing Your Notebook.....	40
To set up password protection.....	40
To attach a security cable	40
To protect against viruses	41
Working in Comfort with a Notebook PC.....	42

Taking Care of Your Notebook.....	44
To protect your hard disk drive	44
To maintain your notebook.....	44
To safeguard your data	45
To extend the life of the display	45
To clean your notebook.....	46
Batteries and Power Management	47
Managing Power Consumption	48
How the notebook manages power automatically.....	48
To manage power manually.....	50
Using Battery Power	51
To check battery status	51
To respond to a low-battery warning	51
To recharge the battery.....	52
To get the most from your batteries.....	52
Modem and Network Connections	55
Using the Modem.....	56
To connect the modem	56
To connect to the Internet.....	58
To disconnect from the Internet.....	59
To dial in to a network.....	59
To change your modem settings	60
To send and receive e-mail.....	60
To send and receive faxes.....	61
Connecting to a LAN	63
To connect to a LAN (selected models)	63
Add-On Devices.....	65
Connecting PC Cards	66
To insert or remove a PC card.....	66
Connecting External Devices	68
To identify connectors for external devices.....	68
To connect a printer or other parallel device	69
To connect a USB device	69
To connect a USB floppy disk drive.....	70
To connect an audio device	71
To connect an IEEE 1394 device (selected models).....	71
To use an external monitor	72
Installing Additional RAM.....	74
To install a RAM expansion module	74
To remove a RAM expansion module.....	75
Replacing the Hard Disk Drive	76

To replace the hard disk drive	76
To replace the hard disk drive holder	77
To prepare a new hard disk drive	77
Troubleshooting and Maintenance.....	79
Troubleshooting Techniques	80
Audio problems	81
CD and DVD problems	82
Display problems.....	84
Floppy disk drive problems	85
Hard disk drive problems	86
Heat problems.....	86
Keyboard, touch pad, and mouse problems	87
LAN problems	88
Memory problems.....	89
Modem problems.....	89
One-Touch button problems	92
Parallel and USB problems	93
PC card (PCMCIA) problems.....	94
Performance problems	95
Power and battery problems	96
Printing problems	98
Startup problems.....	98
Standby and resume problems	99
Testing the Hardware	100
To run the e-DiagTools diagnostic tests	100
Configuring Your Notebook	102
To run the BIOS configuration utility.....	102
Reinstalling and Updating Software	104
To recover the factory installation of your hard disk	104
To replace damaged <i>Recovery CDs</i>	105
To update the notebook BIOS	106
To update Windows drivers.....	107
HP Service and Support	109
Getting Assistance for Your Notebook	110
To get help from HP Instant Support.....	110
To get help from the web.....	110
To contact HP for support or service.....	110
To receive repair service	112
To prepare your notebook for shipment	113
Hewlett-Packard Limited Warranty Statement.....	114

Reference Information.....	117
Hardware Specifications.....	118
Modem Reference Information	120
AT commands (Conexant).....	120
S parameters (Conexant)	126
Selected result codes (Conexant).....	126
Safety Information.....	127
Power cords	127
Ergonomics.....	128
Battery safety.....	128
Laser safety.....	129
Regulatory Information	130
U.S.A.	130
Index.....	133

Getting Started with Your HP Notebook

Taking Inventory

Congratulations! Your HP notebook computer sets a new standard in personal computing. Although compact and easy to carry, your notebook is made with the quality and attention to detail that are the hallmark of Hewlett-Packard.

Your notebook has several features that make it convenient to use:

- The power button provides convenient options for starting and stopping the notebook.
- The notebook includes a variety of connectors that enable you to use it with a wide range of printers, drives, audio equipment, and other external devices.

In addition, most connectors are on or near the back of the notebook, keeping cables away from your working area.

This manual shows how to set up and operate your notebook, as well as what to do if you run into trouble.

What's in the box?

Your HP notebook PC is shipped with these items:

- Battery (installed).
- AC adapter and power cord.
- *Quick Start* sheet.
- *Startup Guide*.
- *Recovery CDs*, for restoring Windows and all software included with your notebook.
- Microsoft Windows manual.
- Telephone cord.

In addition, your notebook includes a variety of preinstalled software. (The exact software installed depends on your particular notebook model.)

To buy accessories

You can buy accessories for your notebook online. For the latest accessories and options, visit the HP Notebook web site at www.hp.com/notebooks.

HP offers a wide variety of accessories, such as the following:

- AC adapters.
- Primary lithium ion battery.
- Additional RAM.
- Ethernet, modem, and LAN cards.
- External USB floppy disk drive.

To find more information

The following table lists sources of information about your notebook and related products.

Source	Description and Location
<i>Quick Start</i> sheet	This pictorial introduction shows you how to get your notebook up and running quickly.
<i>Startup Guide</i>	This printed manual introduces your HP notebook computer, and contains setup instructions, basic operation guidelines, troubleshooting information, and warranty information.
Online <i>Reference Guide</i>	The <i>Reference Guide</i> is shipped on the notebook's hard drive, and provides a complete source for operating and maintaining the notebook. Click Start, All Programs, HP Library, HP Notebook Reference Guide, or look on the <i>Recovery CDs</i> in \hp\library.
Online HP Notes	These contain information that became available after the manuals were completed. Click Start, All Programs, HP Library, HP Notes, or look on the <i>Recovery CDs</i> in \hp\library.
Microsoft Windows manual	This is shipped with your notebook and contains information about using the version of Microsoft Windows shipped with your notebook.
HP Notebook web site	www.hp.com/notebooks . www.europe.hp.com/notebooks (European mirror).

Getting Started with Your HP Notebook
Taking Inventory

HP Business Support web site	www.hp.com/go/bizsupport .
---------------------------------	--

Identifying Parts of the Notebook

Front view

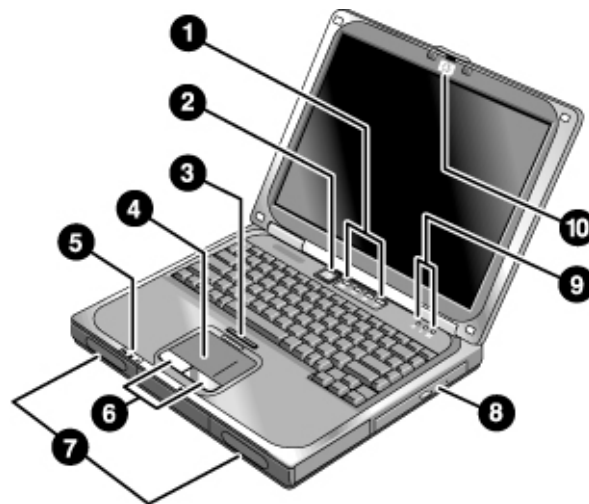

- | | | | |
|---|--|----|--|
| 1 | One-Touch buttons (programmable). | 6 | Left and right click buttons. |
| 2 | Power button. | 7 | Speakers. |
| 3 | Touch pad on-off button. | 8 | DVD, or CD-RW/DVD drive (with eject button). |
| 4 | Touchpad. | 9 | Keyboard status lights (see page 18). |
| 5 | Power, hard disk, and battery status lights (see page 18). | 10 | Latch. |

Getting Started with Your HP Notebook Identifying Parts of the Notebook

Back view

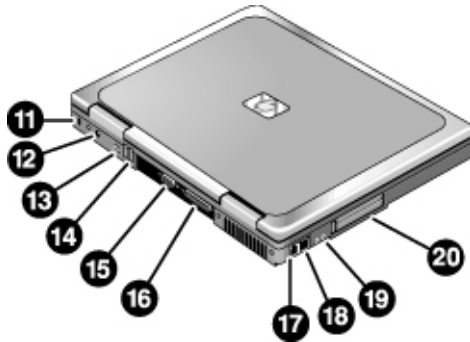

- | | | | |
|----|---|----|---|
| 11 | Kensington lock slot (security connector). | 16 | Parallel port (colored burgundy). |
| 12 | AC adapter jack. | 17 | Modem port. |
| 13 | IEEE 1394 connector (selected models). | 18 | LAN port and indicators (selected models). |
| 14 | USB ports (2). | 19 | External microphone jack (colored pink) and
headphone jack (colored lime green). |
| 15 | External monitor (VGA) port (colored blue). | 20 | PC card slot and eject button. |

Bottom view

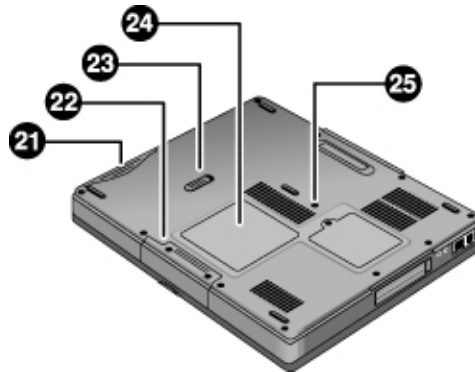

- | | | | |
|----|------------------|----|----------------------|
| 21 | Battery. | 24 | RAM expansion cover. |
| 22 | Hard disk drive. | 25 | System-off switch. |
| 23 | Battery latch. | | |

Status lights

The status lights on the front of the notebook report battery and power status.

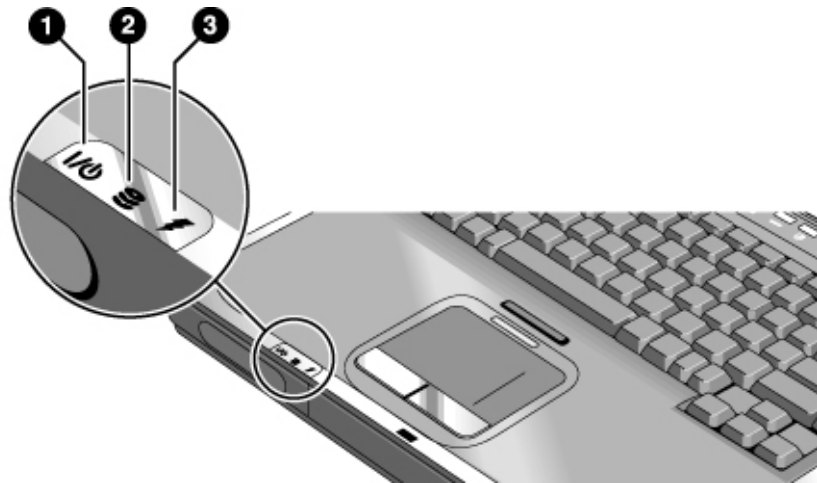

1. **Power mode.** (left LED)
 - Steady blue: the notebook is on (even if the display is off).
 - Flashing blue: the notebook is on standby.
 - Off: the notebook is off or in hibernation.
2. **Hard drive activity.** (center LED)
 - Blue: the notebook is accessing the hard drive.
3. **Battery charge.** (right LED)
 - Green: the AC adapter is connected and the battery is fully charged.
 - Amber: the AC adapter is connected and the battery is charging.
 - Red: the AC adapter is connected and the battery has a fault.
 - Off: the AC adapter is not connected or the battery is missing.

The status lights above the keyboard indicate the state of each keyboard lock.

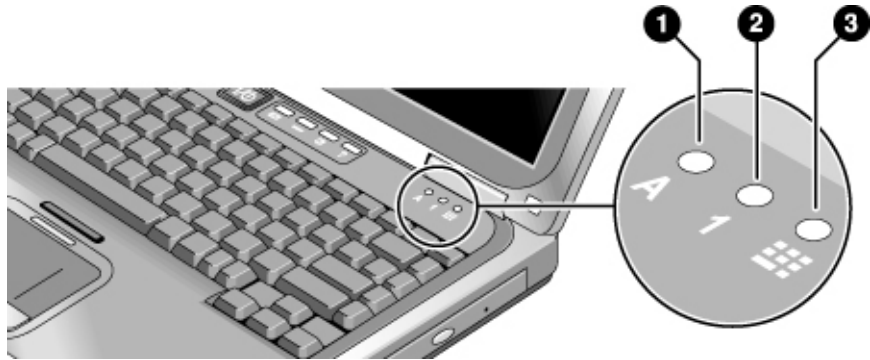

1. **Caps Lock.** Caps Lock is active.
2. **Num Lock.** Num Lock is active. (The Keypad Lock must also be on to use the embedded keypad.)
3. **Pad Lock.** Pad Lock is active.

Setting Up Your Notebook

WARNING

Improper use of keyboards and other input devices has been associated with ergonomic injury. For information about reducing your risk, see “Working in Comfort” in the online HP Library, or visit our ergonomics web site, www.hp.com/ergo. For a summary about working with a notebook computer, see “Working in Comfort with a Notebook PC” on page 42.

If you are using your notebook as your primary computer, or using it for extended periods, you should use it with a full-size keyboard, monitor, and mouse. This can reduce the risk of ergonomic injury. See “Working in Comfort” in the online HP Library.

When you set up your notebook for the first time, you'll need to install and charge the battery, connect the AC adapter and a phone line, turn on the notebook, run the Windows setup program, and register the notebook.

Your notebook comes with an AC adapter rated at 75W. Older HP AC adapters were only rated at 60W. To ensure that your computer operates properly, please be sure that you use only the adapter supplied with this notebook. If it is necessary to replace your adapter, hp recommends you verify that you use only those adapters specifically approved for this model computer.

Step 1: Install the battery

WARNING

Do not mutilate or puncture batteries. Do not dispose of batteries in fire, or they can burst or explode, releasing hazardous chemicals. Rechargeable batteries must be recycled or disposed of properly.

Your notebook is shipped with the battery installed. If the battery has been removed, install it as follows:

- Insert the battery into the battery compartment, then press it in until it clicks into place.

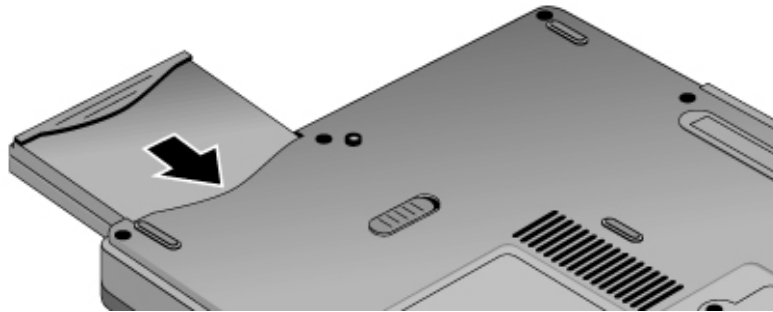

Once you have installed the battery, you can connect the AC adapter to the notebook and charge the battery while you work.

To remove the battery

- Slide the battery's release latch, then pull the battery out of its compartment.

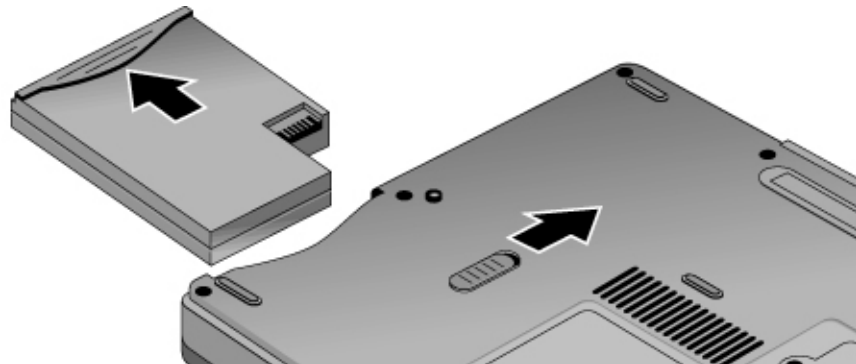

WARNING

Do not mutilate, puncture, or dispose of batteries in fire. A battery can burst or explode, releasing hazardous chemicals. A rechargeable battery must be recycled or disposed of properly.

Getting Started with Your HP Notebook
Setting Up Your Notebook

Step 2: Connect AC power

CAUTION

Use only the HP AC adapter included with your notebook, or another approved HP adapter. Using any other AC adapter can damage the adapter, and may void your warranty—see "Hewlett-Packard Limited Warranty Statement" on page 114.

The pre-installed electronic online manual on your notebook may refer to the use of a 60-watt AC adapter designed for an earlier released product. A 60-watt AC adapter should not be used with this current product.

- Plug the AC adapter into the power source (the adapter's LED lights), then connect it to the AC adapter jack on the back of the notebook. The notebook's battery then begins charging.
- You must fully charge your battery before first using your notebook. The battery indicator light will turn green when fully charged.

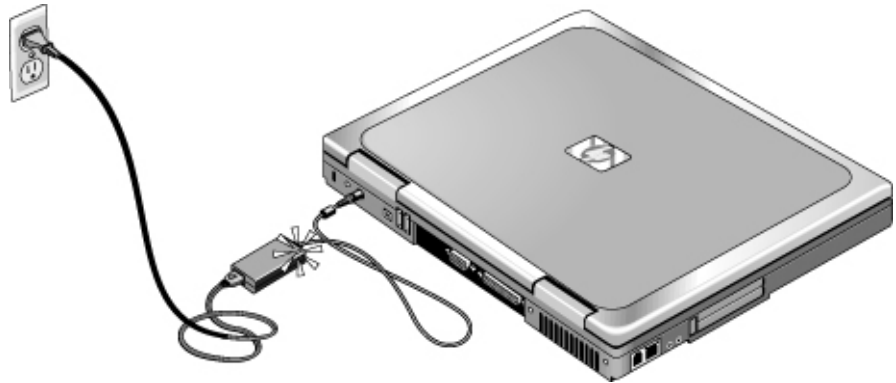

While the battery is charging, you can continue with step 3.

Step 3: Connect a phone line

Your notebook includes a built-in modem. If you prefer, you can instead use a PC card modem or an external modem to connect a phone line.

1. Make sure the telephone line is an analog line. You must not use a digital line. (Many office and some home lines are digital.)
2. Plug the telephone cord into the notebook's modem jack, or into a PC card or external modem. Make sure the cord clicks into place.

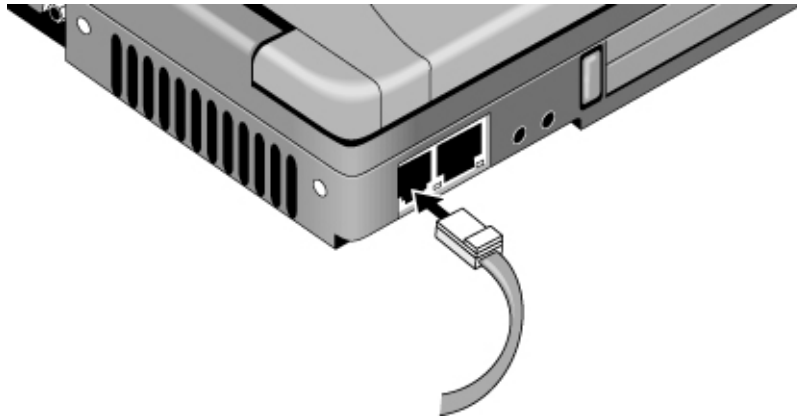

3. Plug the other end of the cord into a telephone jack. If the plug on the phone cord doesn't fit your telephone jack, you may need to use an adapter.

For details about using the modem, see "Using the Modem" on page 56.

Getting Started with Your HP Notebook Setting Up Your Notebook

Step 4: Turn on the notebook

- Press the power button located above the keyboard. The notebook then boots up, and Windows starts automatically.

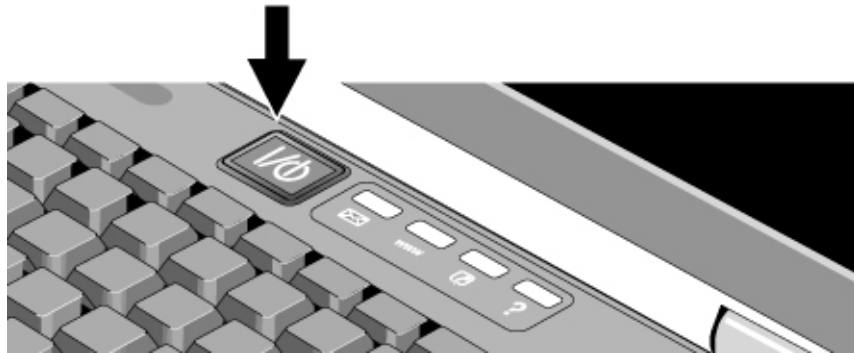

Hint

If your notebook does not turn on when using only its battery, the battery may be discharged. Connect the AC adapter and press the power button again. Leave the AC adapter connected for at least an hour.

Step 5: Set up Windows

Your notebook has Microsoft Windows XP preinstalled on its hard disk drive. The first time you turn on your notebook, a Windows setup program runs automatically.

1. Follow the setup program's instructions as they appear on the screen.
2. Check the modem's country or region settings: click Start, Control Panel, Printers and Other Hardware, Phone and Modem Options. On the Dialing Rules tab, verify the settings for your location, or create a new location.

Note

If you need the Windows XP Product ID code, you'll find it on the bottom of the notebook.

Step 6: Register your notebook

Be sure to register your notebook. Registering is free and fast, and ensures that you will receive quicker, more personalized support. The information you provide during registration is used to provide you with better products and services.

Registering your notebook does the following:

- Records your ownership of the notebook with Hewlett-Packard and provides access to service, support, and information.
- Records your ownership of the Windows XP operating system with Microsoft.

You can register while setting up Windows, or later in any of three ways: by modem, by phone, or by fax. For some countries and models, an HP notebook registration icon is available on the desktop.

By modem

If you decide not to register while setting up Windows, you can register later by modem by double-clicking the HP Notebook Registration icon on the desktop. Make sure the phone line is connected and follow the onscreen instructions. The icon disappears after you register.

By phone

You can register your notebook by calling your HP Customer Care Center—see “To contact HP for support or service” on page 110.

By fax

If you have a printer connected to your notebook, you can print a registration form that you can fax to HP. Double-click the HP Notebook Registration icon on the desktop, and print the registration form. You will find the fax number on the form.

To connect to the Internet

You can use your notebook’s modem or LAN port (selected models) to connect to the Internet. For details, see “Using the Modem” on page 56 or “Connecting to a LAN” on page 63.

Basic Operation

Operating Your Notebook

You can start and stop your notebook using its power button. However, at certain times you may want to use other methods to start or stop the notebook—depending on power considerations, types of active connections, and start-up time.

Note

This manual describes your notebook in its original factory configuration, with all settings at their default values.

To turn the notebook on and off

Power mode	To enter this mode	To turn on again
On Power mode status light is blue.	Press the power button.	
Standby Saves significant power. Turns off the display and other components. Maintains the current session in RAM. Restarts quickly. Restores network connections. Power mode status light flashes blue.	Click Start, Turn Off Computer, Stand By. –or– Press the power button. –or– Allow timeout.	Press the power button to quickly resume your session.
Hibernation Saves maximum power. Saves the current session to disk, then turns off. Restores network connections. Power mode status light is off.	Click Start, Turn Off Computer, then press and hold Shift and click Hibernate. –or– Allow timeout.	Press the power button to resume your session.
Turn off Saves maximum power. Turns off without saving the current session. At startup, resets everything, starts a new session, and restores network connections. Power mode status light is off.	Click Start, Turn Off Computer, Turn Off. –or– Press and hold the power button for four seconds. (Do this only if the Start menu procedure doesn't work.)	Press the power button to start with a new session.

You can customize how these power modes work, and the ways in which you can put the notebook into them. See “Managing Power Consumption” on page 48.

To reset your notebook

Occasionally, you may find that Windows or the notebook has stopped responding. If this happens, try the following in the order listed.

- If possible, turn off the notebook from Windows: click Start, Turn Off Computer, Restart (or Turn Off).
- Press Ctrl+Alt+Del, then click Shut Down, Restart (or Turn Off).
- Press and hold the power button for four seconds, then release it.
- If the notebook still does not turn off, use a straightened paper clip to press the system-off switch on the bottom of the notebook, near the RAM access door.

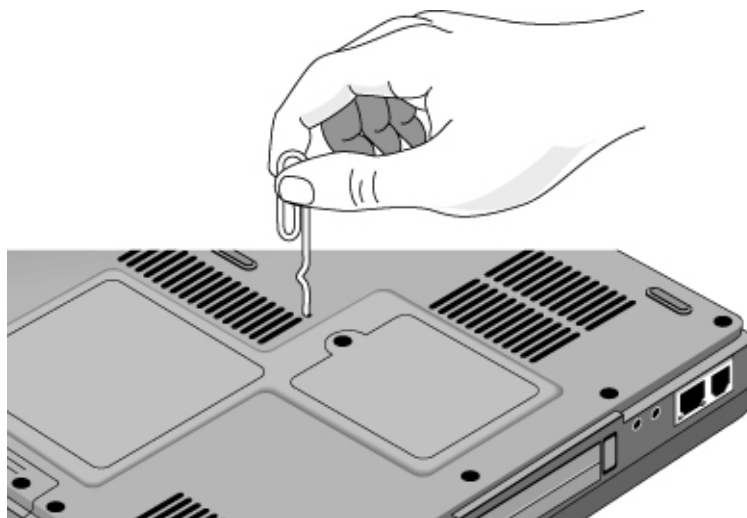

After the notebook turns off, press the power button to turn it on again.

To change the boot device

The notebook normally boots from its internal hard disk. You can also boot the notebook from a floppy disk drive (optional accessory), the CD/DVD drive, or a local area network (LAN).

1. Restart the notebook: click Start, Turn Off Computer, Restart.
2. When the HP logo appears, press Esc to display the Boot menu.
3. Use the arrow keys to select the boot device, and press Enter.

If you want to boot from a specific device whenever it is present, change the boot order using the BIOS configuration utility—see "To run the BIOS configuration utility" on page 102.

To use the touch pad

The touch pad includes an on-off button so you can turn off the touch pad to avoid moving the pointer accidentally, such as by touching the pad while typing. The indicator light turns off when you turn off the touch pad.

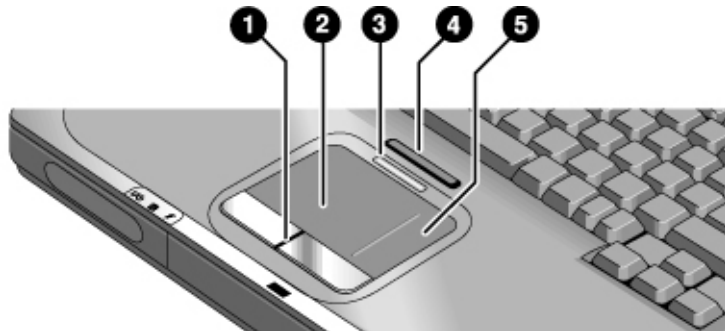

1. Click buttons. The click buttons work like the left and right buttons on a standard mouse.
2. Touch pad (touch-sensitive pointing device).
3. Touch pad on-off indicator light.
4. Touch pad on-off switch.

5. Scroll pad. The scroll pad scrolls the contents of the active window.

Moving and selecting

1. Place your hands in a normal typing position.
2. Move a thumb or finger across the touch pad in the direction you want the pointer to move.
3. Use the left and right click buttons, which function like the left and right buttons on a mouse, to make your selection:
 - To open an application, move the pointer over the icon and double-click the left button.
 - To make menu selections, move the pointer to the menu item and click the left button.
 - To open the shortcut menu for an item, move the pointer over the item and click the right button.
 - To drag an item, move the pointer over the item. Then press *and hold* the left button while you move the pointer to the new location, and release the button.

In addition, you can tap the touch pad to select items and use other advanced touch pad features. For more information, double-click the touch pad icon in the taskbar, and then click Help in the tab for a particular feature.

You can use Mouse in Control Panel or the touch pad icon in the taskbar to customize the operation of your computer's pointing devices (touch pad and external mouse): you can change the left, right, and scroll pad actions, double-click speed, pointer speed, and more.

Scrolling with the scroll pad

- Move your finger down the scroll pad to scroll down through the contents of a window. Move your finger up the scroll pad to scroll up.

To use the Fn hot keys



The combination of the Fn key plus another key creates a *hot key*—a shortcut key sequence—for various system controls.

Basic Operation

Operating Your Notebook

- To use a hot key, press *and hold* Fn, press the appropriate second key, then release both keys.

Hot key	Does this
Fn+F1	Decreases the display's brightness.
Fn+F2	Increases the display's brightness.
Fn+F5	Switches among the built-in display, an external display, and simultaneous display on both.
Fn+F8	Toggles the embedded numeric keypad on and off (see "To use the embedded keypad" on page 34).
Fn+F9	Toggles Num Lock on and off.
Fn+F10	Toggles Scroll Lock on and off (except on an external keyboard).
Fn+Home	Toggles the sound on and off (mutes sound).
Fn+Page Up	Increases sound volume (except on an external keyboard).
Fn+Page Down	Decreases sound volume (except on an external keyboard).

External keyboards do not support Fn hot keys.

To use the One-Touch buttons

Your notebook includes four One-Touch buttons that can start any application or open a document or web site with a single press. The buttons are pre-configured for specific applications, but you can set them to start any applications you want.

- Press the One-Touch button to open the corresponding application, document, or web site.

Your computer is preconfigured to access the following services:

1. Microsoft Outlook Express e-mail software.
2. Internet Browser.
3. HP Business Center.
4. Help and Support.



To configure a One-Touch button

1. Click Start, Control Panel, Printers and Other Hardware, Keyboard.
2. On the HP One-Touch tab, click the button you want to reprogram.
3. Type a label for the button, then select the application, document, folder, or web site you want the button to open.
4. If you want a label to appear onscreen when you press a One-Touch button, select that option on the Onscreen Display tab.

Note

Pressing a One-Touch button will resume the notebook from standby or hibernation, or turn the notebook on. It will not, however, bypass any password protection you have in place.

To use the Windows and Applications keys



The Windows key brings up the Windows Start menu. This is the same as clicking the Start button on the taskbar.



The Applications key brings up the shortcut menu for the current application. This is the same menu that appears when you click the right mouse button while pointing at the application.

Windows key combinations

Key combination	Does this
Windows key+BREAK	Opens System Properties.
Windows key+E	Opens My Computer.
Windows key+F1	Opens Help and Support.
Windows key+F	Opens the Search dialog.
Windows key+M	Minimizes all displayed windows.
Shift+Windows key+M	Returns all minimized windows to original size.
Windows key+R	Opens the Run dialog.
Windows key+U	Opens the Utility Manager.

To use the embedded keypad

Your notebook's built-in keyboard includes an embedded keypad you can use to type numbers and arithmetic operators or to move the cursor. The keys in the embedded keypad are marked using light blue characters.

- Press Fn+F8 to turn on the embedded keypad.
- Hold Fn while typing a key to turn the embedded keypad on temporarily.

When the embedded keypad is active, you can use Num Lock to change how the keypad functions. Press Fn+F9 to turn number lock on or off.

- Num Lock on: The keys enter the numbers and arithmetic operator printed in light blue on the keyboard.
- Num Lock off: The keys move the cursor, in the same way as is marked on external keyboards.

To adjust the display

Changing the brightness

- To decrease the brightness, press Fn+F1.
- To increase the brightness, press Fn+F2.
- To adjust display settings, click Start, All Programs, Hewlett-Packard, Notebook, HP Display Settings, HP Display Settings. You can also display a settings icon in the taskbar for quick access.

When you are using battery power, the display dims automatically to conserve power. You can use the brightness controls to override this adjustment.

Hint

To maximize your battery's operating time, set the brightness to the lowest level you can view comfortably.

Changing display settings

You can customize a number of display settings for your notebook, such as color depth and screen area.

1. Click Start, Control Panel, Appearance and Themes, Display.
2. Click the Settings tab, then adjust the settings you want.
3. Click the Appearance tab to customize fonts, icons, menus, and other display elements used throughout Windows XP.

The notebook has an LCD display, which behaves differently than a typical computer monitor. If you change the display resolution, the desktop changes size, but the objects on the desktop do not. You normally won't need to change the resolution except to use an external monitor.

Using an external monitor

Your notebook includes a connector that enables you to attach an external monitor—see "To use an external monitor" on page 72.

To adjust the volume

From the keyboard

- To increase the volume, press Fn+Page Up.
- To decrease the volume, press Fn+Page Down.

In Windows

1. Click the speaker symbol in the taskbar (if not present, see Windows Help).
2. Drag the volume control bar up or down to adjust the volume.

Muting the speakers

Your notebook also provides ways to mute its speakers without changing the volume setting. This can be handy when you want to block all speaker output regardless of what the notebook is doing. To mute the speakers, do either of the following:

- Press Fn+Home.
- Click the speaker icon in the taskbar, then click Mute.

To insert or remove a CD or DVD

CAUTION

Do not remove a CD or DVD while the notebook is reading it. Otherwise, the notebook could stop responding and you could lose data. Before opening the drive, use the stop or eject control in your multimedia player software to make sure the drive is not running.

Be sure to press the disk onto the spindle. You can damage the disk or drive if you only lay it on the tray.

1. Press the button on the face of the drive. If you are using this drive for the first time, be sure to remove any packing material that may be present.

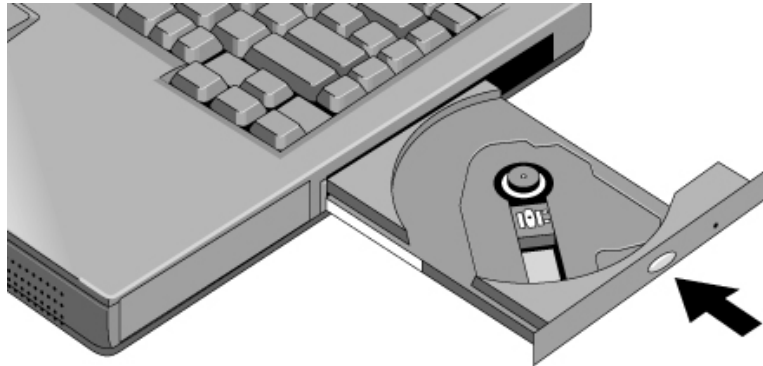

2. Place the disk into the drive (label facing up) and gently press down until the disk snaps onto the spindle.

–or–

Remove the disk.

3. Slide the tray back into the drive to close it.

If the notebook loses power, you can manually open the drive:

- Insert a pin or straightened paper clip into the emergency eject hole on the drive door to open it.

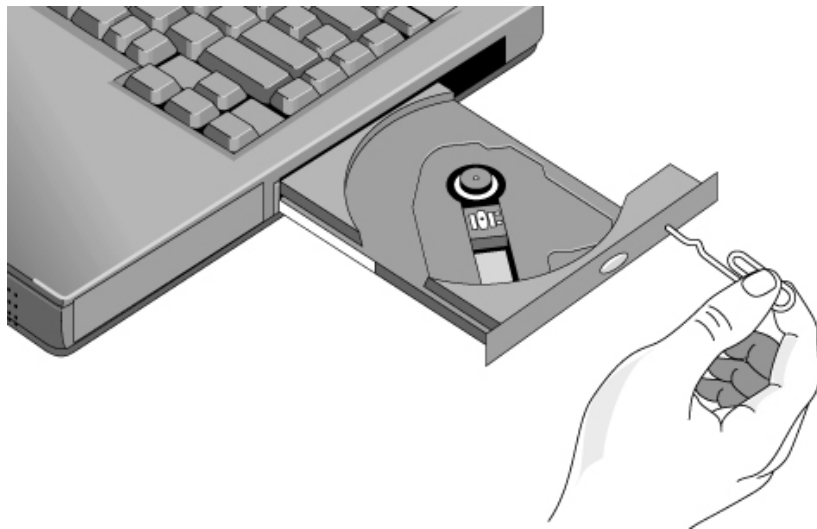

To play DVD movies

If your notebook came with a DVD drive, it also includes DVD player software that lets you play DVD movies.

- Click Start, All Programs, Multimedia, DVD Player, InterVideo WinDVD. (The name of the DVD player program can vary.)

–or–

Click Start, All Programs, Windows Media Player.

If you need to install the DVD player software, click Start, Run, type C:\HP\PROGRAMS\DVD\SETUP.EXE, then press Enter.

Important

DVDs have regional codes embedded in their disk data. These codes prevent DVD movies from being played outside the region of the world in which they are sold.

Most DVD drives let you change the region code only a limited number of times (usually no more than four) to allow you to set the proper region code for your area. Please note that when you reach this limit, your last change to the region code will be hard-coded on the DVD drive, and will be permanent. **Your HP warranty does *not* cover the expense of correcting this situation.**

Refer to the help for your DVD player software for details about setting region codes.

Note

The DVD player in your notebook performs to high and advanced specifications. It would *not* benefit from the installation of a software program called “PC Friendly” that is included with many DVDs. HP recommends against installing PC Friendly on your notebook, as it can cause your DVD player to perform erratically and produce errors. If this happens, uninstall PC Friendly and restart your notebook.

To create or copy CDs

If your notebook came with a CD-RW or DVD/CD-RW drive, it also includes software that lets you copy or create CDs.

- Click Start, All Programs, Multimedia, CD Writer, RecordNow. (The name of the CD-RW software can vary.)

–or–

Click Start, All Programs, Windows Media Player. You can also use Windows Explorer to create data CDs using a CD-RW or DVD/CD-RW drive.

If you need to install the CD-RW software, run Setup on the software CD.

Refer to the software's help for details about creating or copying CDs. For best results use HP certified media. While other media may work, HP cannot guarantee compatibility.

Securing Your Notebook

It is important to maintain security of your notebook and your data. You can improve security by locking your notebook with a cable and setting up virus protection.

To set up password protection

You can protect your notebook from unauthorized access by setting up password protection through Windows. This provides protection when the notebook is restarted by requiring the user to enter the password.

1. Click Start, Control Panel, User Accounts, then select your account.
2. Click Create a Password, then set a password.
3. Click Start, Control Panel, Performance and Maintenance, Power Options.
4. On the Advanced tab, select the option to prompt for a password when the notebook resumes from standby.

To cancel password protection, set an empty password.

To attach a security cable

Your notebook includes a built-in connector you can use to secure the notebook with a cable and a lock (such as the Kensington MicroSaver lock system, available at many computer stores).

1. Wrap the cable around a stationary object, such as a table leg.
2. Loop the cable to create a slipknot around the stationary object—make sure it can't slip off.
3. Insert the lock into the notebook's security connector and release the key. Store the key in a safe place away from the notebook.

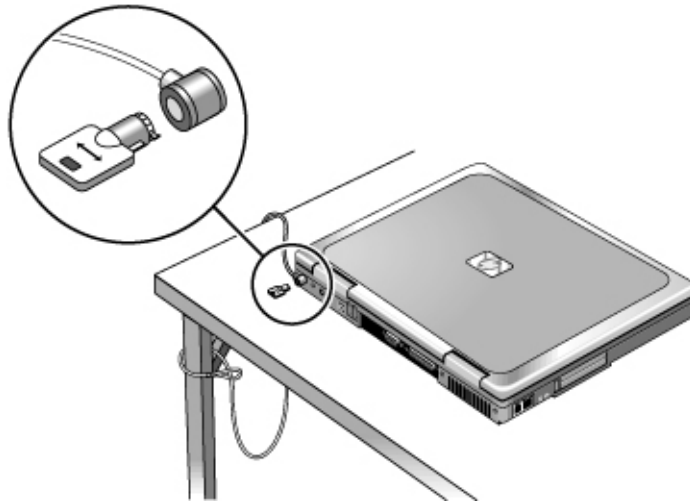

To protect against viruses

Virus-protection software can help protect the integrity of your data. This is especially important if you use the Internet.

Your notebook includes Norton AntiVirus software. If this software is not already installed, install it as follows:

1. Click Start, All Programs, Norton AntiVirus, Install Norton AntiVirus.
2. Follow the instructions as they appear on the screen.

Once installed, you can get detailed instructions from the software's online help.

Working in Comfort with a Notebook PC

You can use your HP notebook computer virtually anywhere, anytime. The following recommendations should help you work more comfortably.

Note that if you are using your portable computer as your primary computer or for extended periods, you should use it with a full-size keyboard, monitor, and mouse. This will give your notebook the adjustability and comfort features of a desktop unit. More information on how to prepare your workspace environment and set up your HP equipment is available in *Working in Comfort*, which is preloaded on the hard disk in the HP Library (click Start, Help and Support, HP Library) and available on the *Recovery CDs* in \hp\library—as well as at www.hp.com/ergo.

WARNING

Improper use of keyboards and other input devices has been associated with ergonomic injury. For more information about reducing your risk, visit our ergonomics web site or see *Working in Comfort* in the online HP Library.

Your mobile work environment

- Use a chair that provides good support for your lower back. If an adjustable chair is not available, you can use a pillow or rolled-up towel to provide lower back support.
- Try to keep your thighs parallel to the floor and your feet flat on the floor. In a mobile environment, you can do this by using a phone book or briefcase to support your feet.
- Adjust the height of either your work surface or chair to keep your arms in a neutral position. Your arms should be relaxed and loose, elbows at your sides, with the forearms and hands parallel with the floor.
- Position your notebook's display to minimize glare and reflection. For example, on an airplane, lower the window shade; or in a hotel room, draw the curtains. You should also maintain a comfortable viewing distance—approximately 40 to 60 cm (16 to 24 inches). Adjust the angle of your display to help keep your head angled slightly downward in a comfortable position.

Using your notebook computer

- Position the notebook so your wrists and hands are in a neutral position. Your wrists should be as straight as possible and should not have to bend sideways or more than 10 degrees up or down. Your HP notebook computer has a built-in palm rest, which is ideal for this purpose.
- Try to type as lightly as possible. The notebook's keyboard requires little force to activate.
- Take frequent, short rest breaks—this is especially important in a mobile computing environment.
- Portable computers weigh between approximately 1.5 and 4 kilograms (approximately 3 to 8 pounds). When traveling, be sure to carry your notebook computer properly to minimize strain on your body. Shift the bag containing your notebook equipment frequently between your left and right hands and shoulders.

Taking Care of Your Notebook

Use the following recommendations to maintain your notebook during everyday use and prevent potential damage or data loss.

To protect your hard disk drive

Hard disk drives, like other internal notebook components, can be damaged by inappropriate handling and operation.

- Avoid bumping or jolting the notebook.
- Do not operate the notebook while traveling over bumpy terrain.
- Turn off the notebook or put it on standby or into hibernation before transporting it. This turns off the hard drive. A drop of even a few inches while the hard drive is operating could destroy data or damage the drive.
- Carry the notebook in a padded case to protect against bumps and jolts.
- Set the notebook down gently.

To maintain your notebook

- Provide adequate ventilation around the notebook. Make sure there is adequate clearance at the back of the notebook, so that its fan vent is not blocked.
- Always set the notebook on a flat surface, so that air can flow freely around and underneath it. Do not place an operating notebook on carpeting, clothing, or other soft surface, as this can block the fan's air intake on the bottom of the notebook.
- Always turn off the notebook or put it into hibernation before placing it in a carrying case or other enclosed space.
- Do not pick up or carry the notebook by its display.
- Observe the temperature limits and other specifications listed in "Hardware Specifications" on page 118. Do not use the notebook outside in the rain or snow (inclement weather). If the notebook is cold, warm it gradually to avoid condensation.

To safeguard your data

- Do not touch the touch pad or activate any other device that interrupts operation while the system is starting up, turning off, or entering into or resuming from standby or hibernation.
- Back up your work regularly. Copy files to floppy disk, tape, CD-RW, or network drives.
- Use a virus-scanning program (such as the Norton AntiVirus program included with your notebook) to check the integrity of your files and operating system. Since new viruses appear frequently, you should also update the program's virus definitions from time to time. Updates for Norton AntiVirus are available at www.symantec.com.
- Check the notebook's hard disk periodically: click Start, My Computer, and select the disk you want to scan. Click File, Properties, then select the Tools tab and click Check Now.

To extend the life of the display

- Set the display brightness to the lowest comfortable level (Fn+F1).
- When working at your desk, connect an external monitor and turn off the internal display (Fn+F5).
- If you are not using an external monitor, set the Turn off monitor timeouts (for both AC and battery operation) to the shortest comfortable interval.
- Avoid using a screen saver or other software that prevents the notebook from going on standby after a timeout period. If you use a screen saver, enable the option to shut off the display after a time delay.
- Do not disable the standby timeout.
- If you are using AC power and have no external monitor attached, put the notebook on standby or into hibernation when not in use.

See "To adjust the display" on page 35 for details about adjusting the display, and "To set power management properties" on page 49 for information about setting timeouts.

To clean your notebook

You can clean your notebook with a soft cloth dampened with clean water or with water containing a mild detergent.

- Do not use an excessively wet cloth or allow water inside the case.
- Do not use abrasive cleaners, especially on the display. Do not apply any type of cleaner directly to the display: instead, apply the cleaner to a soft cloth, then gently wipe the display.
- You can clean the keyboard with a vacuum cleaner to remove accumulated dust.

Batteries and Power Management

Managing Power Consumption

When you're running your notebook on battery power, you'll want to maximize operating time without compromising performance. Your notebook includes several power-saving features that will help you do this.

- During idle periods, the notebook automatically enters power-saving modes after specified timeout periods. You can adjust these timeouts to suit your working habits.
- You can also manually send the notebook into a power-saving mode whenever you need—see “To manage power manually” on page 50.

How the notebook manages power automatically

Your notebook automatically turns off the hard disk and display, goes on standby, and goes into hibernation based on values set in Power Options in Control Panel.

Automatic action	Occurs after...	To resume...
Turns off hard disk. Turns off the hard disk drive. This is usually set to occur shortly after the display is turned off.	No hard disk access for the specified interval.	Begin using the notebook: the hard disk turns on when needed.
Turns off display. Turns off the display to conserve battery power and extend the life of the display.	No keyboard, pointing device, or other input activity for the specified interval.	Press any key or move a pointing device to turn on the display.
Enters standby. Maintains your current session in RAM, and turns off the display and other components to conserve battery power.	No keyboard or pointing device activity, no disk drive access, and no port activity for the specified interval.	Press the power button to quickly resume your session.
Enters hibernation. Saves your current session to the hard disk, then turns off the notebook. Provides maximum power savings while still allowing you to recover your current session.	The notebook stays on standby for the specified interval, or when the battery becomes critically low (see “To respond to a low-battery warning” on page 51).	Press the power button to resume your session.

CAUTION

Make a habit of saving your work before allowing your notebook to go on standby. If power is interrupted while the notebook is on standby, any unsaved data will be lost.

Note

The notebook can go on standby, go into hibernation, or turn off if battery power reaches a critically low level. (See “To respond to a low-battery warning” on page 51.) If this happens, you will find on resuming that your data has been saved, but some functions may be disabled. To resume normal operation, restore power by connecting the AC adapter or installing a charged battery, then turn the notebook off and restart it.

To set power management properties

You can adjust the periods of non-use after which your notebook automatically shuts down components or enters a power-saving mode. You can also save these settings as a power scheme.

In addition, you can specify how the notebook acts when battery power drops to low levels, and how it responds when you press the power button or close the lid.

1. Click Start, Control Panel, Performance and Maintenance, Power Options.
2. On the Power Schemes tab, enter the timeout settings you prefer. If you don't want a particular timeout to occur, set the value to Never. (This is not recommended for hibernation.)

If you want to save the settings as a power scheme, click Save As and enter a name for the scheme.

3. Click the Alarms tab, and specify the actions the notebook takes when battery power drops to a low or critical level.
4. Click the Hibernate tab, and make sure hibernation support is enabled.

CAUTION

If hibernation is not enabled, you will lose any unsaved data if the notebook's battery runs down completely.

5. Click the Advanced tab, and set the actions the notebook takes when you close the lid or press the power button.

See Windows Help and Support for details.

Batteries and Power Management

Managing Power Consumption

To manage power manually

In addition to allowing the notebook to enter its power-saving modes automatically, you can also put it into any of the following three modes whenever you need to.

Power mode	Does this...	Use when...	To enter this mode...
Standby	Maintains your current session in RAM, and turns off the display and other components.	You will be away from your notebook for up to several hours.	Click Start, Turn Off Computer, Stand By. – or – Press the power button.
Hibernation	Saves the current session to the hard disk, then turns off. Provides maximum power savings while still allowing you to recover the current session. Restores network connections.	You will be away from your notebook for a day or more, but want to continue your session.	Click Start, Turn Off Computer, then press and hold Shift and click Hibernate.
Off	Turns off your notebook for maximum power savings. The current session is not saved, and any unsaved data is lost.	You're done with your work.	Click Start, Turn Off Computer, Turn Off. – or – Press and hold the power button for four seconds. (Do this only if the Start menu procedure doesn't work).

CAUTION

Make a habit of saving your work before putting your notebook on standby. If power is interrupted while the notebook is on standby, any unsaved data will be lost.

You can also turn off the display by closing the lid.

In addition, you can configure the notebook so that closing the lid or pressing the power button puts the notebook on standby or into hibernation, or turns it off—see “To set power management properties” on page 49.

Using Battery Power

To check battery status

From the battery charge light

The battery charge light on the front of the notebook shows whether the notebook's battery is charging or fully charged—see “Status lights” on page 18.

From the Windows taskbar

The Windows taskbar includes a power icon that provides detailed battery status information (see Windows Help and Support for details). The icon looks like a battery when AC is not connected.

- Place the pointer over the power icon to display the remaining battery charge. This value is shown as either a percentage of charge remaining, or as time remaining.
- Double-click the power icon to open the Power Meter window.
- Click the power icon to display a menu of the available power schemes.
- Right-click the power icon to view the options for displaying power information.

From the Windows Control Panel

- Click Start, Control Panel, Performance and Maintenance, Power Options, then click the Power Meter tab to see battery status. The Alarms and Advanced tabs provide additional power-information options.

On the battery

1. Remove the battery from the notebook—see page 20.
2. Press the contact pad on the side of the battery. The number of lights that turn on indicates the remaining charge: each light represents 20% of a full charge.

To respond to a low-battery warning

The notebook automatically alerts you when battery power drops to a critically low level. If you do not restore power within a short time, the system goes into hibernation.

Batteries and Power Management

Using Battery Power

Once the notebook enters hibernation in this way, you won't be able to turn it on again until you restore power by doing one of the following:

- Connect the AC adapter (see "Step 2: Connect AC power" on page 22).
- Replace the battery with one that is charged (see "Step 1: Install the battery" on page 20).

Note

If you connect the AC adapter, you can continue to work while your battery recharges.

To recharge the battery

CAUTION

The AC adapter is normally warm whenever plugged into an AC outlet. The notebook's battery is normally warm while recharging. Do not recharge the notebook in a briefcase or other confined space, or its battery could overheat.

- To recharge the battery, connect the AC adapter to the notebook.

To get the longest operating time, wait until the battery's charge is below 20% before recharging, then charge it fully (100%). You can continue working while the battery charges.

To get the most from your batteries

Follow these suggestions to make your battery's power last as long as possible.

- Connect the AC adapter, especially while using the CD/DVD drive or any external connection such as a PC card, modem, or floppy disk drive.
- Set the display brightness to the lowest comfortable level (Fn+F1).
- Put the notebook on standby whenever you will not be using it for up to several hours.
- Put the notebook into hibernation whenever you want to save your current session, but will not be using the notebook for a day or more.
- Set the automatic timeout settings to emphasize saving power—see "How the notebook manages power automatically" on page 48.
- If you have an I/O PC card—that is, a PC card having an external connection, such as a network card—remove it when you're not using it. Some I/O cards use significant power even when inactive.

- If you work with an application that uses an I/O PC card, exit the application when you finish using it.
- See “Managing Power Consumption” on page 48 for other ideas about reducing power consumption while the notebook is not in use.

In addition, follow these suggestions to extend the life of your battery.

- Do not leave a battery unused for long periods. If you have more than one, rotate them.
- If you normally use AC power, make a practice of using the battery as your power source at least once a week.
- Charge the battery regularly.
- For long-term storage, the battery must be charged 20–50% to minimize capacity loss by self-discharge and to avoid deterioration of performance. Storing a fully charged battery can cause higher self-discharge and reduce its discharge capacity—even after recharging—compared to a battery stored when charged 20–50%.
- To maintain maximum battery capacity and accuracy of the battery gauge, perform this procedure about once a month. Restart the notebook, press F6 when the HP logo appears, and follow the instructions that appear onscreen. The process calibrates the battery, and requires four to five hours to complete. You cannot use the notebook during this process.

Modem and Network Connections

Using the Modem

By connecting your notebook's modem to a telephone line, you can use the notebook to communicate with other networked computers. You can explore the Internet, send and receive e-mail messages, and send and receive faxes. Your notebook contains several software programs that work with your modem:

- Internet Explorer, for browsing the World Wide Web.
- Outlook Express, for sending and receiving e-mail messages.
- Fax Console for sending and receiving faxes.

Your notebook includes a built-in high-speed V.90/92 modem. This modem allows you to connect to any Internet Service Provider (ISP) that has V.90/92 interoperable modems. Check with your ISP for a list of telephone numbers that support V.90/92.

Note that the maximum speed for faxing is 14.4Kbps. Even though the built-in modem is capable of downloading at 56Kbps, your ISP may not operate at this speed; please check with your service provider for information. Transmission rates also depend on the condition of the telephone line.

If you prefer to use a different modem, you can install a PC card modem or attach an external modem to the USB port.

To connect the modem

CAUTION

To reduce the risk of fire, use only No. 26 AWG or larger telecommunications line cord to connect the modem to the telephone wall jack.

1. Make sure the telephone line is an analog line (sometimes called a data line). You must not use a digital line.
2. Connect the telephone cord to the built-in modem.

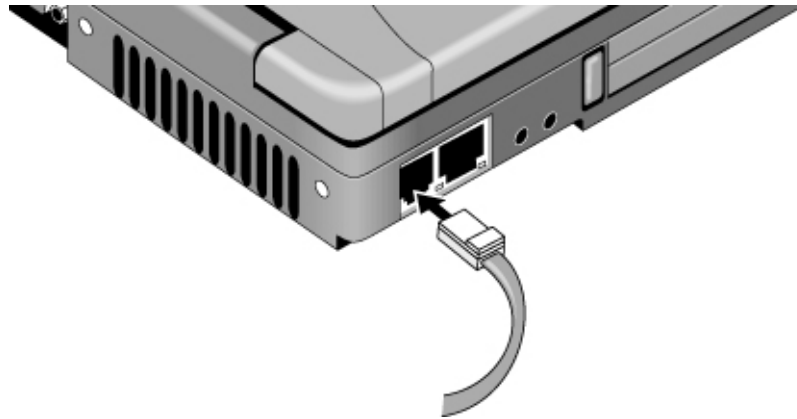

3. Plug the other end of the phone cord into a telephone jack. If the plug on the phone cord doesn't fit the jack, you may need to use an adapter.
4. Check your modem's country or region settings: click Start, Control Panel, Printers and Other Hardware, Phone and Modem Options.

CAUTION

Your built-in modem may not work with multiple phone lines or a private branch exchange (PBX), cannot be connected to a coin-operated telephone, and does not work with party lines. Some of these connections may result in excess voltage and cause the modem to malfunction. Check your telephone line type before connecting your phone line to your notebook.

Special notes about using a modem in certain countries

- The pulse dialing feature may be disabled in some countries, possibly because Loop Disconnect is not certified there. If pulse dialing is disabled, use tone dialing connections only.
- Many countries impose a blackout period after a modem repeatedly fails to connect to a service provider. The number of failed attempts and the time you must wait before trying again differ from country to country. Check with your telephone company. For example, if you were dialing from Italy and failed to connect to your server or canceled the connection, you would have to wait one minute before dialing that number again. If you dialed before then, you would get an error message reading "delay." After the fourth failed connection, you would need to wait one hour before trying the number again. If you dialed before the hour was up, you would get a message reading "black list."
- When using a modem in the Republic of South Africa, you may need to use an external surge protector to prevent damage to your notebook from power surges

Modem and Network Connections

Using the Modem

caused by lightning or other sources. Connect an approved surge protector to the modem cable whenever you use the modem.

To connect to the Internet

If you have not yet signed up with an Internet Service Provider (ISP), see “To connect to the Internet” on page 25 for instructions.

When you have signed up with an ISP, you can connect to the Internet as follows:

- If you signed up with AOL, AT&T WorldNet, Compuserve 2000, Earthlink, or MSN, double-click the appropriate icon in the Online Services folder on the desktop (if available).

–or–

Click Start, All Programs, Easy Internet Signup.

- If you signed up with another ISP, double-click the Internet Explorer icon on the desktop (if available), or click Start, Internet Explorer. Then click the Connect button in the Dial-up Connection or Network Connection window.

To display a connect icon (two connected computers) in the taskbar icon whenever you are connected, click Start, Control Panel, Network and Internet Connections, Network Connections. Then right-click the connection, select Properties, and select the icon option.

You are now ready to explore the Internet. To go to a specific web site, enter the address (for example, www.hp.com) in the browser’s address field. To search for information on the Web, you can use the browser’s search tool and enter the word or phrase you’re looking for.

To use AOL as your ISP

When you use AOL as your Internet Service Provider, you can access the Internet only with AOL’s own software; you can’t use a standard browser such as Internet Explorer. As a result:

- You cannot view web sites by clicking on links (such as those in the electronic *Reference Guide* that link to the HP notebook web site).
- You cannot go to a web site by entering the address in Windows Explorer.

If you try to access the Internet without using the AOL software, the Internet Connection wizard automatically launches, asking you to sign up for an ISP. If this happens, cancel the wizard and launch AOL.

For additional ISP information, refer to the Microsoft manual included with your notebook, or to Windows Help and Support.

To disconnect from the Internet

Once connected to the Internet, your notebook's modem remains connected until you turn off the notebook, disconnect the phone line from the notebook, or give a command to end the connection.

- To disconnect from AOL, use the Sign Off menu.
- To disconnect from other ISPs, double-click the connect icon in the taskbar, then click Disconnect. (You can enable this icon as described in "To connect to the Internet," above.)

–or–

Click Start, Control Panel, Network and Internet Connections, Network Connections, then right-click the connection and select Disconnect.

To dial in to a network

You can use your notebook's modem to dial in to a LAN (local area network) that supports dial-in connections. This gives you access to network resources from a remote location.

- See Windows Help and Support for information about setting up and using dial-in network connections.

To change your modem settings

The modem is already set up to be compatible with telephone systems and modems in most areas. However, in some situations you may have to change modem settings to match local conditions and requirements. If you have questions about such requirements, contact your telephone company.

- **Control Panel.** Click Start, Control Panel, Printers and Other Hardware, Phone and Modem Options to change many modem settings. Click Properties on the Modems tab to set connection speeds, or click Edit on the Dialing Rules tab to set dialing options.
- **Communications software.** Many communications applications provide options for controlling modem settings. See the help for your software.
- **AT commands.** You can control many aspects of modem operation using modem AT commands, which are specific strings of characters sent to the modem to set up specific conditions. For a list of AT commands for the built-in modem, see “Modem Reference Information” on page 120.

Click Start, Control Panel, Printers and Other Hardware, Phone and Modem Options. On the Modems tab, click Properties. You can type AT commands on the Advanced tab in the space for Extra settings.

To send and receive e-mail

The steps for sending and receiving e-mail depend on your ISP. If you are using AOL, e-mail is part of your AOL service. For other ISPs, you can use Outlook Express (included with your notebook) or an e-mail system of your choice. This section includes instructions for using Outlook Express.

To start Outlook Express

1. Double-click the Outlook Express icon on the desktop (if available).

–or–

Click Start, All Programs, Outlook Express.

2. If you are not currently connected to the Internet, the Dial-up Connection window appears. Choose Connect to connect to the Internet.

To send an e-mail message

1. Start Outlook Express.

2. Click the Create Mail tool on the toolbar.
3. Fill in the information in the New Message window.
4. When you're finished, click the Send button.

To receive e-mail messages

1. Start Outlook Express.
2. Click the Send/Recv tool on the toolbar to have Outlook deliver new messages.
3. Click the Inbox folder to view the list of messages. Unread messages appear bold on the screen.
4. To view a message, click it once. (Or double-click to view the message in its own window.)

To send and receive faxes

Sending and receiving faxes requires just a telephone connection—you don't need an Internet connection. You can use the modem and the Fax Services software (including the Fax Console application) provided with Windows XP to send and receive faxes with your notebook.

To set up Fax Services

Before you can use Fax Services, you need to install it.

1. Click Start, Control Panel, Add or Remove Programs.
2. Click Add/Remove Windows Components, select Fax Services, and follow the instructions on the screen. You may need the Windows CDs to complete installation.

To start the Fax Console application

- Click Start, All Programs, Accessories, Communications, Fax, Fax Console.

The first time you start Fax Console, the Fax Configuration wizard steps you through the process of setting options and customizing the program for your use. Follow the onscreen instructions. If you're not sure which setting to choose, accept the default.

To send a fax

- Click Start, All Programs, Accessories, Communications, Fax, Send a Fax, then follow the instructions that appear on the screen.

Modem and Network Connections

Using the Modem

If you want to send a document as a fax, open the document in its application window, then open the Print dialog. Change the selected printer to Fax, then print.

To receive faxes

Faxes are automatically received when Fax Console is running in an open or minimized window. New faxes are indicated in the status box in the Fax Console window. To receive a fax manually, do the following:

- When a fax call is coming in, click Receive Now in the Fax Console menu bar.

To view and print a fax

1. In the Fax Console tree, click Inbox, then double-click the fax you want to view.
2. Click the printer icon to print the fax.

Connecting to a LAN

If your notebook has a LAN port, you can use it to connect to a local area network (LAN). This gives you access to network resources—such as printers and file servers on your corporate network—and in some cases to the Internet.

To connect to a LAN (selected models)

1. Make sure the existing LAN supports Ethernet 10Base-T (10 Mbps) or 100Base-TX (100 Mbps) connections.
2. Plug the LAN cable (not supplied) into the built-in LAN port. The cable must have an RJ-45 connector.

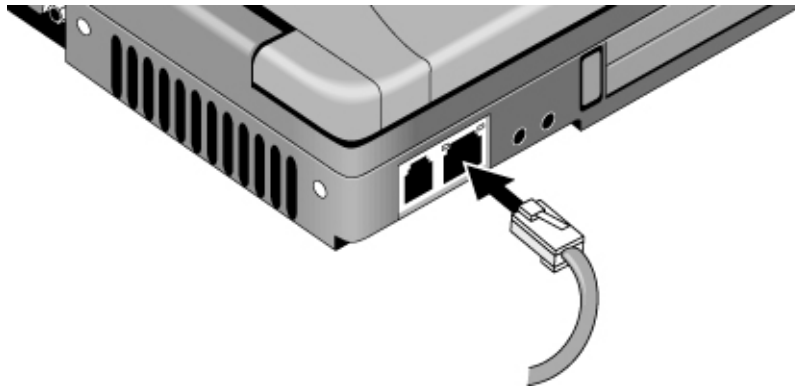

3. Windows automatically detects and sets up the LAN connection. To edit the settings, open Network Connections or Network and Dial-Up Connections in Control Panel.

Two lights above the LAN port indicate the status of the connection (see the figure above):

- The yellow light indicates network activity.
- The green light indicates that a link is established to the network.

See Windows Help and Support or your Microsoft manual for information about setting up and using LAN connections. Contact your network administrator or ISP provider for network information.

Modem and Network Connections

Connecting to a LAN

Note

In some circumstances, your notebook's advanced power-saving features can cause file transfers through the notebook's LAN to appear to respond more slowly when the notebook is running on battery power. To avoid such problems, connect the notebook's AC adapter whenever you plan to transfer files through the LAN.

If AC power is not available, you can instead use the BIOS configuration utility to set I/O Performance to Max I/O Performance—see "To run the BIOS configuration utility" on page 102. This will, however, significantly reduce the battery's operating time by disabling the notebook's standby and hibernate timeouts.

Add-On Devices

Connecting PC Cards

The notebook's PC card slot expands the notebook's data storage and communication capabilities, and supports standard Type I, II, and III PC cards (PCMCIA and CardBus).

CAUTION

Do not remove a PC card while the notebook is reading or writing data. If you do, you could lose data, or the notebook could stop responding.

To insert or remove a PC card

Inserting a PC Card

1. Hold the card with its face up and its connector holes toward the card slot.
2. Slide the PC card into the bottom slot, and press firmly to make sure it seats properly. Most cards are properly seated when the outer edge is flush with the casing of the notebook, but some cards are designed to protrude from the case.



Removing a PC card

CAUTION

Before removing a PC card, you must use the Safely Remove Hardware icon in the taskbar, or else turn off the notebook. Otherwise, you could lose data.

1. Stop the PC card: double-click the Safely Remove Hardware icon in the taskbar, select the PC card you want to stop, then click Stop.

2. Press the PC card eject button once, so that it extends from the side of the notebook.



3. Press the eject button again to eject the PC card, and pull the card out of the notebook.

To reestablish network connection after resume

When using a network PC card, you may lose a network connection after resuming from standby or hibernation. If this happens, restart the card by removing and reinserting it.

Finding tested PC Cards

For a list of PC cards that have been tested and approved for use with your notebook, visit the Accessories section of the HP Notebook web site (www.hp.com/notebooks).

Note

In some circumstances, your notebook's advanced power-saving features can cause file transfers through a PC card to appear to respond more slowly when the notebook is running on battery power. To avoid such problems, connect the notebook's AC adapter whenever you plan to transfer files through a PC card.

Connecting External Devices

You can connect external components—such as a printer, mouse, monitor, or keyboard—directly to your notebook.

To identify connectors for external devices

The diagram below shows your notebook's connectors for external devices.

Note

Before you connect any device, check its documentation to see if you need to make any settings or adjustments to the equipment before using it. This might include setting switches so the equipment will operate properly with your notebook and the software you plan to use.

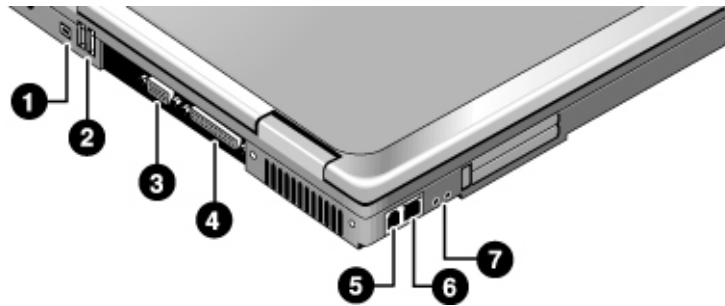

1. IEEE 1394 devices (selected models).
2. USB ports (2).
3. External monitor (VGA) port (blue).
4. Parallel port (burgundy).
5. Modem port.
6. LAN port and indicators (selected models).
7. Headphone jack (lime green) and microphone jack (pink).

To connect a printer or other parallel device

The notebook's parallel port uses a standard 25-pin connector, most commonly used for connecting dot-matrix, ink-jet, and laser printers.

- Connect the device's parallel cable to your notebook's parallel port.

To connect a USB device

The universal serial bus (USB) provides a bidirectional serial interface for adding peripheral devices—such as a game controller, keyboard, mouse, serial or parallel port, or scanner—on a single bus. Your notebook includes two USB ports.

- Attach the device's USB cable to a USB port on the notebook. Windows automatically recognizes the USB device.

Some USB devices can be connected to the notebook in series—this is called a daisy-chain connection.

Note

If you have problems using a USB device, contact the vendor of the device, and visit the HP notebook web site (www.hp.com/notebooks) for the latest versions of the USB drivers.

USB keyboards do not support Fn hot keys.

To connect a USB floppy disk drive

If you have an optional floppy disk drive, you can connect it to your notebook's USB port using the external floppy drive cable.

- Connect the cable from the USB floppy drive directly to the notebook's USB port.



If you have questions about the installation, configuration, or general use of your USB floppy disk drive, consult your Reference or Startup Guides or contact the nearest HP Customer Care Center:

- Web site: www.hp.com/omnibook/support/index.
- United States: (970) 635-1000 (select option 3 and then option 4).
- Canada: (905) 206-4663 English (select option 3 and then option 4).
- Europe: +44 (0) 171-512-52-02 English International.

To connect an audio device

Your notebook includes an external audio jack and a microphone jack that let you plug in an external microphone or an audio output device such as external speakers or headphones.

- Attach the audio cable to the appropriate port on your notebook.

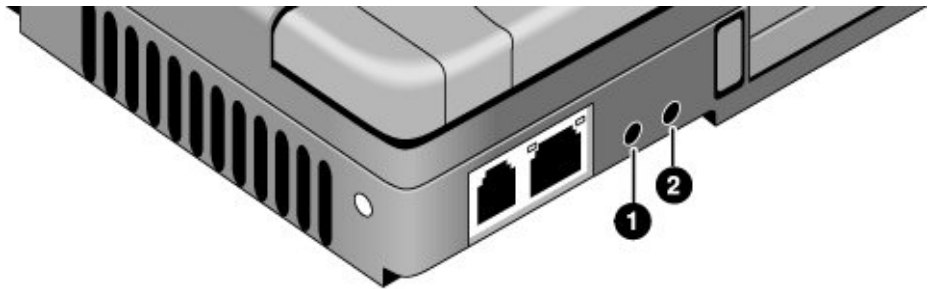

1. Microphone jack (pink).
2. Headphone jack (lime green).

Note

When you plug a device into your notebook's headphone jack, the notebook's built-in speakers automatically turn off.

To connect an IEEE 1394 device (selected models)

If your notebook includes an IEEE 1394 port (located on the notebooks back panel), you can use it to connect devices such as audio and video equipment, disk drives, printers and other computers. Attach the device's cable to the IEEE 1394 port on the notebook's back panel. Windows automatically recognizes the device.

Note

If you have problems making this connection, contact the device manufacturer and the HP Business Store web site (www.hp.com/go/bizsupport) for the latest version of the driver for the device.

To use an external monitor

You can connect your notebook to an external monitor and then use it or the notebook's built-in display—or both at once.

To connect an external monitor

1. Put the notebook on standby or turn it off: click Start, Turn Off Computer, Stand By (or Turn Off).
2. Connect the monitor cable from the monitor to the external monitor (VGA) port on the back of the notebook.
3. Connect the monitor to a power source and turn it on.
4. Press the power button to turn on the notebook.

To switch the display

When you connect an external monitor, the notebook automatically switches to the monitor. To switch the display device, do one of the following:

- Press Fn+F5 to cycle through the display options: notebook display, external monitor, both.
- Click Start, All Programs, Hewlett-Packard, Notebook, HP Display Settings, HP Display Settings.

To adjust monitor resolution

1. Click Start, Control Panel, Appearance and Themes, Display.
2. On the Settings tab, adjust the Screen area.

To use dual display mode

You can extend your notebook's desktop by connecting an external monitor to your notebook and using it and the built-in display simultaneously. This requires you to set your notebook's display as follows.

1. Click Start, Control Panel, Appearance and Themes, Display.
2. On the Settings tab, set screen resolution to 1024×768 pixels, and color quality to Medium (16 bit) or Highest (24 bit).
3. Turn off the notebook.

4. Connect the monitor cable from the monitor to the external monitor (VGA) port on the back of the notebook.
5. Connect the monitor to a power source and turn it on.
6. Press the power button to turn on the notebook. Windows automatically detects the second monitor and attempts to load the proper display driver. Follow the onscreen instructions.
7. Click Start, Control Panel, Appearance and Themes, Display, Settings. Position the second monitor to the right or left of your notebook display to match your monitor's location.
8. Make sure the option to extend the Windows desktop onto the monitor is checked.

You can change the Screen area and Colors settings for the second monitor by selecting Display #2. These settings do not need to be the same as those for your notebook's built-in display.

Installing Additional RAM

Your notebook has no built-in memory (RAM), but has two slots for removable RAM modules in a compartment on the bottom of the unit. (One of these slots contains a module installed at the factory). You can use these slots to expand your unit's RAM. Use HP PC133 SDRAM modules only, or your notebook will not boot up.

You'll need a small (#0) Phillips screwdriver for these procedures.

To install a RAM expansion module

To increase your notebook's RAM, you can install a RAM module in the expansion slot on the bottom of the notebook. Use HP PC133 SDRAM modules only.

CAUTION

Your notebook's chips are extremely sensitive to static electricity, and can be permanently damaged by it. Handle the RAM module only by its edges. Before installing the memory module, discharge your body's static electricity by touching the metal shielding around the connectors on the rear of the notebook.

1. Turn off the notebook: click Start, Turn Off Computer, Turn Off.
2. **Important:** unplug the AC adapter (if present) and remove the notebook's battery.
3. On the bottom of the notebook, loosen the screw holding the RAM cover (the cover retains the screw), and remove the cover.
4. Insert the RAM module into the connector at about a 30° angle until it's fully inserted. Then press down on both sides of the module until it latches.

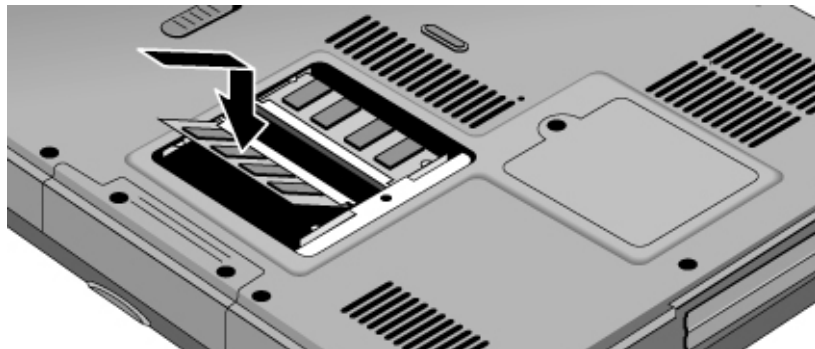

5. Replace the RAM cover.
6. Reinstall the notebook's battery.

To remove a RAM expansion module

1. Turn off the notebook: click Start, Turn Off Computer, Turn Off.
2. **Important:** unplug the AC adapter (if present) and remove the notebook's battery.
3. On the bottom of the notebook, loosen the screw holding the RAM cover (the cover retains the screw), and remove the cover.
4. Release the two latches at the sides of the RAM expansion module by pushing them gently outward (away from the sides of the module). When you release the latches, the free edge of the module pops up.

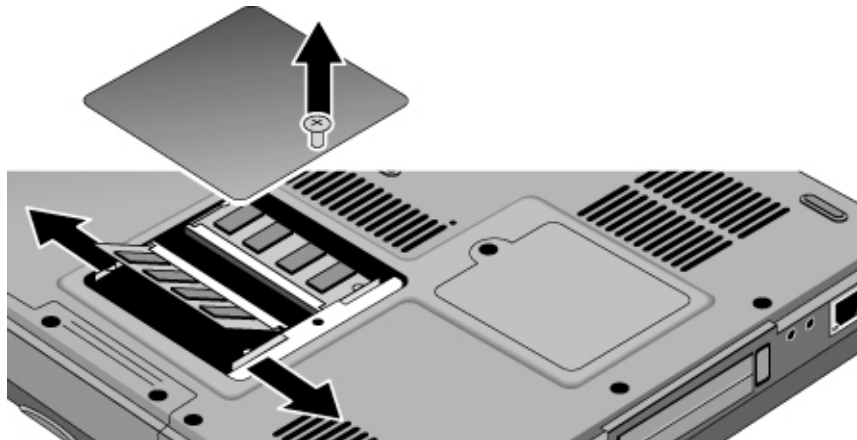

5. Pull the module out of the connector.

Important

The notebook will not operate without at least one RAM module installed.

6. Replace the RAM cover.
7. Reinstall the notebook's battery.

Replacing the Hard Disk Drive

To replace the hard disk drive

You'll need a small (#0) Phillips screwdriver for this procedure.

1. Unplug the AC adapter, if present, and remove the notebook's battery.
2. Remove both hard drive retaining screws from the bottom of the notebook.

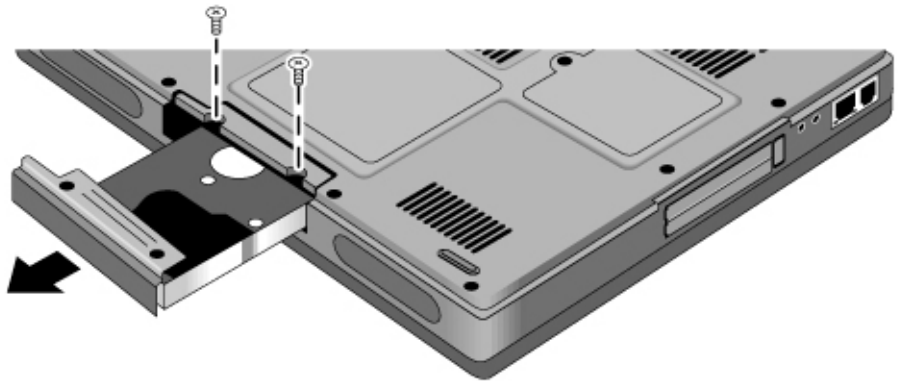

3. Pull the hard drive out of the notebook.
4. Carefully slide the new drive into the hard drive compartment. Press firmly to make sure its connector seats properly.
5. Reinstall the hard drive retaining screws.

Important

If you are installing a new hard disk drive, create a Utility partition on the drive before loading any software—see “To recover the factory installation of your hard disk” on page 104.

To replace the hard disk drive holder

If you are installing a new hard drive that does not have a holder, you can remove the holder from the old hard drive. You'll need a small (#0) Phillips screwdriver for this procedure.

1. Remove all four screws from the holder and drive case, then remove the drive from the holder.

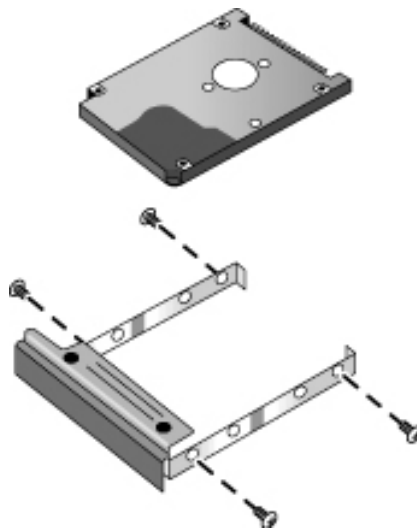

2. Insert the drive into the holder, then reinstall all four screws into the holder and drive case.

To prepare a new hard disk drive

When you install a new hard disk drive, you must prepare it to work with your notebook by installing the Windows software and operating system that were originally installed on your notebook. Do this using the *Recovery CDs* that came with your notebook—see “To recover the factory installation of your hard disk” on page 104.

Troubleshooting and Maintenance

Troubleshooting Techniques

This section contains solutions to several types of problems you might experience while using your notebook. Try the solutions one at a time, in the order in which they are presented.

Here are some other sources of information for troubleshooting:

- Open the HP web-based troubleshooting tool: click Start, Help and Support, HP Instant Support. Search or browse the troubleshooting database for the information related to your problem.
- Click Start, Help and Support, Fixing a Problem, and use the Windows troubleshooters.
- See the Microsoft Windows manual shipped with your notebook.
- For updated information, see the HP Notes in the online HP Library (click Start, All Programs, HP Library, HP Notes) or on the *Recovery CDs* in \hp\library.
- Find technical tips and software updates for your notebook at the HP Business Support web site (www.hp.com/go/bizsupport).
- Test your notebook by running the e-DiagTools test program—see “Testing the Hardware” on page 100.
- Contact your dealer or Hewlett-Packard—see “To contact HP for support or service” on page 110. Please have your notebook with you when you call.

Audio problems

If sound is not audible

- Press Fn+Page Up several times.
- Click the speaker icon in the taskbar (if present), and make sure Mute is not checked and the Volume slider is not set to the bottom.
- Double-click the speaker icon in the taskbar and make sure the audio source is not muted. If the source is not displayed, click Options, Properties, and select the source from the volume control list.

If sound does not record

- Make sure the microphone is securely connected to the microphone jack.
- Check the software controls for recording sound: Click Start, All Programs, Accessories, Multimedia (or Entertainment), Sound Recorder.
- Double-click the speaker symbol in the taskbar. Then click Options, Properties, and make sure the microphone is enabled in the recording controls.
- Test the audio with the e-DiagTools diagnostics—see “Testing the Hardware” on page 100.

If the PC card detection beep(s) at startup are very loud and volume cannot be adjusted

- Download the latest audio driver from the technical support area of the HP notebook web site (www.hp.com/notebooks).

If you hear a loud high-pitched whine (feedback) from the speakers

- Double-click the speaker symbol in the taskbar, and try reducing the master volume.

CD and DVD problems

If you can't boot from a CD in the CD/DVD drive

- Make sure the CD is bootable, such as the *Recovery CDs*.
- Make sure the CD/DVD drive is selected as the boot device—see “To change the boot device” on page 30.
- Restart the notebook.
- Test the CD/DVD drive with the e-DiagTools diagnostics—see “Testing the Hardware” on page 100.

If the notebook cannot read a CD or DVD

- Make sure the disk is properly inserted, and snapped down onto the spindle in the center of the tray.
- For a single-sided CD or DVD, make sure the disk is placed in the drive with the label facing up.
- Wait 5 to 10 seconds after closing the tray for the notebook to recognize the disk.
- Clean the disk with a soft cloth.
- Remove the disk from the drive, then restart the notebook.
- If you created the CD on a CD-RW drive module, try using a different media brand. For best results use HP certified media. While other media may work, HP cannot guarantee compatibility.

If a CD or DVD plays erratically

- Dirt or smudges can cause a disk to skip. Clean the disk with a soft cloth. If the disk is badly scratched, it may have to be replaced.
- Some DVDs include software called “PC Friendly”. You generally should not install this software, as it can cause errors or erratic play. If needed, uninstall it and restart your notebook.

If a DVD movie stops playing in the middle

- The DVD may be double-sided. Open the DVD tray and read the text near the center of the disk. If it says Side A, turn the disk over.
- You may have accidentally paused the DVD movie. Press the Play button to continue.

If you get a Region Code error when playing a DVD movie

- DVDs have regional codes embedded in their disk data. These codes prevent DVD movies from being played outside the region of the world in which they are sold. If you get a Region Code error, you are trying to play a DVD intended for a different region.

Important: most DVD drives let you change the region code only a limited number of times (usually no more than four) to allow you to set the proper region code for your area. Please note that when you reach this limit, your last change to the region code will be hard-coded on the DVD drive, and will be permanent. **Your HP warranty does *not* cover the expense of correcting this situation.**

Refer to the help for your DVD player software for details about setting region codes.

If the DVD movie doesn't fill the screen

- Each side of a double-sided DVD has a different format (standard or widescreen). In widescreen format, black bands appear at the top and bottom of the screen. To view the standard format, turn the disk over and play the other side.

If a DVD doesn't play with two displays

- Before starting the DVD player, press Fn+F5 to switch to one display. You cannot switch displays once the DVD player is started.
- If you're using both displays, the DVD image will not appear on any display set up as "secondary." Click Start, Control Panel, Appearance and Themes, Display. Click Advanced on the Settings tab, then click the S3Display tab and change settings.

Display problems

If the notebook is on, but the screen is blank

- Move the mouse or tap the touch pad. This will wake the display if it is off.
- Try pressing Fn+F2 to increase the brightness.
- Press Fn+F5 in case the internal display was disabled. (Do this three times to return to the state you started from.)
- If the notebook is cold, allow it to warm up.

If the screen is difficult to read

- Check whether the display resolution is set to its default of 1024×768: click Start, Control Panel, Appearance and Themes, Display, Settings.
- Try adjusting the size of the desktop icons and labels—see “To adjust the display” on page 35.

If part of the Windows desktop is not visible and you have to scroll down to see the taskbar, or if the desktop does not fill the entire display and has a black border

- Your display resolution may be set incorrectly. Adjust the resolution as needed—see “To adjust the display” on page 35.

If an external display does not work

- Check the connections.
- Press Fn+F5 in case the external monitor was disabled. (Do this three times to return to the state you started from.)
- Test the display with the e-DiagTools diagnostics—see “Testing the Hardware” on page 100.

If one or more pixels look bad on a TFT display

TFT display manufacturing is a highly precise but imperfect technology, and manufacturers cannot produce displays that are cosmetically perfect. Most, if not all, TFT displays exhibit some level of cosmetic imperfection. These cosmetic imperfections may be visible under varying display conditions, and can appear as bright, dim, or dark spots. *This issue is common across all vendors supplying TFT displays in their products and is not specific to the HP notebook display.*

HP notebook TFT displays meet or exceed all HP standards for cosmetic quality of TFT displays. HP does not warrant that the displays will be free of cosmetic imperfections. *TFT displays can have a small number of cosmetic imperfections and still conform to HP's cosmetic quality specifications, including the following:*

- No more than 6 pixels remain on (always one color, such as white, red, green, or blue dots).
- No more than 6 pixels remain off (always dark).
- No more than a total of 8 pixels stuck on or off.
- No other stuck pixel within 15 mm of a stuck pixel.

Contact HP Customer Care if you have a display quality problem and require a more comprehensive explanation of HP display quality—see “To contact HP for support or service” on page 110. We expect that over time the industry will continue to produce displays with fewer inherent cosmetic imperfections, and we will adjust our HP guidelines as these improvements are implemented.

Floppy disk drive problems

If a floppy drive connected to the USB port doesn't work

- Make sure the drive is securely connected to the notebook.
- Restart the notebook: click Start, Turn Off Computer, Restart.

Hard disk drive problems

If the notebook's hard drive doesn't spin

- Make sure the notebook has power. If necessary, connect the AC adapter, and make sure it is plugged securely into a power source and into the back of the notebook.

If the hard disk makes a buzzing or whining noise

- Back up the drive immediately.
- See whether the noise is coming from elsewhere, such as the fan.

If files are corrupted

- Run the Norton AntiVirus program—see “To protect against viruses” on page 41.
- Check the hard disk: open My Computer, select the disk you want to scan, then click File, Properties, and use the Tools tab.
- Test the hard disk drive with the e-DiagTools diagnostics—see “Testing the Hardware” on page 100.
- If necessary, format the hard disk and reinstall the original factory software—see “To recover the factory installation of your hard disk” on page 104.

The hard drive's reported capacity is less than its actual size

- The hard disk drive is preconfigured to allocate some space to diagnostic software, which is used for support and service of your notebook. This part of the hard drive is unavailable for other uses, and so is not included in the capacity of the hard drive as reported by Windows (My Computer, Properties).

Heat problems

Keep in mind that your notebook normally gets warm during routine operation. Charging the battery and running games and other programs that drive CPU usage toward 100% can further increase the notebook's temperature.

If the notebook gets abnormally hot

- Provide adequate ventilation around the notebook. Make sure there is adequate clearance at the back of the notebook, so that its fan vent is not blocked.

- Always set the notebook on a flat surface, so that air can flow freely around and underneath it. Do not place an operating notebook on carpeting, clothing, or other soft surface, as this can block the fan's air intake on the bottom of the notebook.
- Always turn off the notebook or put it into hibernation before placing it in a carrying case or other enclosed space.
- Make sure the fan is working properly. If needed, test the fan's operation—see “Testing the Hardware” on page 100.

Keyboard, touch pad, and mouse problems

If the touch pad is difficult to control

- Customize the touch pad by modifying Mouse properties: click Start, Control Panel, Printers and Other Hardware, Mouse.

If the pointing devices don't work

- Don't use the touch pad while the notebook is starting up or resuming from standby or hibernation. If this happens, try the following:
 - Press any key on the keyboard.
 - Put the notebook on standby, then resume operation.
- Restart the notebook: click Start, Turn Off Computer, Restart.
- Test the keyboard and pointing devices with the e-DiagTools diagnostics—see “Testing the Hardware” on page 100.

If the embedded numeric keypad doesn't work

- To type numbers make sure Num Lock is on.
- Make sure the embedded Keypad Lock (Fn+F8) is on—or that you press and hold the Fn key to temporarily access the embedded keypad.

If a special feature on a USB mouse doesn't work

- Make sure you installed any drivers included with the mouse.
- Restart the notebook, so that it will detect the mouse.

LAN problems

If the built-in network adapter doesn't connect to the LAN

- Check all cables and connections. Try connecting at a different network station, if available.
- If the green light next to the LAN port does not light, the LAN cable may not be connected to the network or the network may be down. Try connecting a different notebook to the cable.
- Click Start, Control Panel, Network and Internet Connections, Network Connections. Make sure you have the correct clients and protocols installed.
- Make sure the LAN cable is Category 3, 4, or 5 for 10Base-T operation, or Category 5 for 100Base-TX operation. Maximum cable length is 100 meters (330 feet).
- Use the networking problems troubleshooter in Windows Help and Support.
- Click Start, Control Panel, Performance and Maintenance, System. On the Hardware tab, open the Device Manager. If the network interface is disabled, try to enable it. If it has a conflict, try disabling another device.

If you can't browse My Network Places

- Click Start, Search to look for a computer.
- Check with your network administrator to make sure NetBEUI protocol is supported on the network.

If you can't log in to Netware servers

- If a Netware server is using IPX/SPX protocol, you may need to force your frame type to match the server's frame type. Check with your network administrator.

If the notebook stops responding after booting

- Check whether you have a TCP/IP network with no DHCP server. This can cause a long delay at startup because DHCP is enabled. Contact your network administrator to determine the proper TCP/IP configuration.

If file transfers are unusually slow or produce timeout errors

- Connect the AC adapter.
- Use the BIOS configuration utility to set I/O Performance to Max I/O Performance—see "To run the BIOS configuration utility" on page 102. (This significantly reduces

the battery's operating time by disabling the notebook's standby and hibernate timeouts.)

Memory problems

If a message says you are out of memory

- Make sure drive C is not running low on free space.
- Use the memory troubleshooter in Windows Help and Support.
- If you are having memory problems running MS-DOS programs, use the application and software problems troubleshooter in Windows Help and Support.
- Not all third-party memory cards have been tested for use with your notebook. Please check the HP Notebook web site (www.hp.com/notebooks) for a list of approved and tested memory cards.
- Test your notebook's memory with the e-DiagTools diagnostics—see “Testing the Hardware” on page 100.

If memory doesn't increase after adding RAM

- Make sure all RAM modules are installed properly.
- Test your notebook's memory with the e-DiagTools diagnostics—see “Testing the Hardware” on page 100.

If the notebook will not boot up after adding RAM

- Make sure your notebook is using only PC133 RAM modules, or it will not boot up. (You will also see an error message.)

Modem problems

If the modem seems slow

- Try another telephone line, preferably one normally used for a fax machine or modem.
- Eliminate extra connections in the line. If possible, connect directly to the wall jack.

Troubleshooting and Maintenance

Troubleshooting Techniques

- Check for excess static or noise on the line, which reduces the overall transmission speed. If necessary, contact your telephone company about fixing this type of problem. (If you're dialing internationally, line noise can be difficult to eliminate.)
- If you have call-waiting, disable it—see Windows Help and Support, and contact your telephone company for information.

If the modem doesn't dial or no dial tone is detected

- Make sure someone else isn't using the same phone line.
- Check all cables and connections.
- Connect a standard telephone to the phone line and make sure the line is working.
- Try another telephone line, preferably one normally used for a fax machine or modem.
- If you're in a foreign country, the dial tone may not be recognized by the modem. Click Start, Control Panel, Printers and Other Hardware, Phone and Modem Options. Select your modem on the Modems tab, then click Properties, Modem, and disable the option that waits for a dial tone.

If the modem dials incorrectly

- Make sure the number you're calling isn't busy.
- Check the telephone number you entered, including any digits required for outside access or long distance.
- In Control Panel, open Phone and Modem Options, and check the dialing options—look for duplicate digits for outside access or long distance.
- If you have call-waiting, disable it—see Windows Help and Support, and contact your telephone company for information.

If the modem dials but doesn't connect

- Make sure you're using an analog telephone line. You must not use a digital line. In a hotel, ask for a data line.
- Try another telephone line, preferably one normally used for a fax machine or modem.
- The modem at the other end may have a problem. Try dialing to a different modem.

If the modem will not connect at 56K speed

- Connection speed depends on several factors, such as the condition of the telephone line. Try connecting another time.

- Make sure the host modem supports a 56K (V.90) connection speed.

If the modem will not connect at any speed

- If you have a single telephone line for voice and modem use, make sure no one else is using the line and that the phone is not off the hook.
- Make sure you're using an analog telephone line. You must not use a digital line. In a hotel, ask for a data line.
- Make sure the telephone line goes directly from the notebook's modem phone jack to the telephone jack on the wall.
- Try another telephone line, preferably one normally used for a fax machine or modem.
- Contact your Internet Service Provider (ISP). It's possible that service may be unavailable temporarily or that your settings are incorrect.
- Restart your notebook and attempt another connection.
- Download the latest modem driver from the technical support area of the HP notebook web site www.hp.com/notebooks.
- Run the modem diagnostics:
 1. Click Start, Control Panel, Printers and Other Hardware, Phone and Modem Options.
 2. Click the Modems tab, and select the modem you want to test.
 3. Click Properties, Diagnostics, Query Modem.

If the modem isn't detected

- Check the modem setup: click Start, Control Panel, Printers and Other Hardware, Phone and Modem Options.
- Click Start, Control Panel, Performance and Maintenance, System. On the Hardware tab, open the Device Manager. If the modem is disabled, try to enable it. If it has a conflict, try disabling another device.
- If you're running fax software using fax Class 2, try using Class 1.

If the modem dials but you can't hear it

- Check the speaker volume setting and mute setting.
- Click Start, Control Panel, Printers and Other Hardware, Phone and Modem Options. Select the modem, click Properties, then check the volume setting on the Modem tab.

Troubleshooting and Maintenance

Troubleshooting Techniques

If the modem connects, but transferred data is bad

- Click Start, Control Panel, Printers and Other Hardware, Phone and Modem Options. Make sure the hardware settings match on the sending and receiving modems.

If the modem causes an ERROR message

- A string of AT commands may contain an incorrect command. If you entered commands as extra settings for the modem in Control Panel or in your communications software, check the commands.

If the modem doesn't fax

- If you're using fax Class 2 in the fax software, try using Class 1.
- Close any other communications programs.
- If you're faxing by printing from an application, make sure you've selected the fax printer.
- Try turning off power management features temporarily.

If the modem clicks repeatedly but doesn't connect

- Make sure you're using an analog telephone line. You must not use a digital line. In a hotel, ask for a data line.
- Check all cables and connections.

One-Touch button problems

If One-Touch buttons are not working properly

- Make sure the items associated with the buttons are the ones you want—see “To use the One-Touch buttons” on page 32.

If the onscreen display does not appear when pressing a One-Touch button

- Make sure the Onscreen Display is enabled—see “To use the One-Touch buttons” on page 32.

Parallel and USB problems

If a USB mouse doesn't work

- Make sure you followed the manufacturer's installation instructions completely and have installed the mouse properly. If not, repeat the procedure.
- Make sure the mouse is securely connected to the USB port.
- Put the notebook on standby, then resume.
- Restart the notebook.
- Check the mouse settings: click Start, Control Panel, Printers and Other Hardware, Mouse.
- Check the port settings in Control Panel: click Start, Control Panel, Performance and Maintenance, System. On the Hardware tab, open the Device Manager, and double-click Ports (COM & LPT).

If a USB modem doesn't work properly

- See "Modem problems" on page 89.
- Make sure the modem is securely connected to the USB port.
- Use the modem troubleshooter (under Networking problems) in Windows Help and Support.
- Check the modem settings: click Start, Control Panel, Printers and Other Hardware, Phone and Modem Options.
- Disable the notebook's internal modem:
 1. Click Start, Control Panel, Performance and Maintenance, System.
 2. On the Hardware tab, open the Device Manager.
 3. Double-click Modem, then double-click the internal modem.
 4. Select the option to disable the modem.
- Check the port settings: click Start, Control Panel, Performance and Maintenance, System. On the hardware tab, open the Device Manager, then double-click Universal Serial Bus controllers.

Troubleshooting and Maintenance

Troubleshooting Techniques

If the parallel port is not working

- Make sure the port connection is secure.
- Check the port settings in Control Panel: click Start, Control Panel, Performance and Maintenance, System. On the Hardware tab, open the Device Manager, and double-click Ports (COM & LPT).
- Test the port with the e-DiagTools diagnostics—see “Testing the Hardware” on page 100.

If the USB port is not working

- Contact the vendor of the peripheral device—and the HP Notebook web site (www.hp.com/notebooks)—for the latest versions of the USB drivers and the driver for the device.
- Check the port settings in Control Panel: click Start, Control Panel, Performance and Maintenance, System. On the Hardware tab, open the Device Manager, and double-click Universal Serial Bus controllers.
- Test the USB port with the e-DiagTools diagnostics—see “Testing the Hardware” on page 100.

PC card (PCMCIA) problems

If the notebook doesn't recognize a PC card

- Make sure the card is fully inserted in the bottom slot.
- Remove and reinsert the PC card.
- Restart the notebook.
- Check the HP Business Support web site (www.hp.com/go/bizsupport) for information about installing certain PC cards.
- Make sure your notebook supports the PC card: check the HP Notebook web site (www.hp.com/notebooks) for a list of approved and tested PC cards.
- Try the card in another computer to see whether the card functions properly.
- If the card requires an IRQ, make sure one is available. If necessary, set the IRQ to an unused value: click Start, Control Panel, Performance and Maintenance, System. On the Hardware tab, open the Device Manager, then view resources by type.

- Test the PC card with the e-DiagTools diagnostics—see “Testing the Hardware” on page 100.

If an I/O card stops communicating properly

- The card may have been reset if your notebook went on standby or into hibernation, or turned off. Exit any applications, then remove and reinsert the card.

If a PC card modem is not working

- Disable the internal modem:
 1. Click Start, Control Panel, Performance and Maintenance, System.
 2. On the Hardware tab, open the Device Manager.
 3. Double-click Modem, then double-click the internal modem.
 4. Select the option to disable the modem.

If file transfers through the PC card are unusually slow or produce timeout errors

- Connect the AC adapter.
- Use the BIOS configuration utility to set I/O Performance to Max I/O Performance—see “To run the BIOS configuration utility” on page 102. (This significantly reduces the battery’s operating time by disabling the notebook’s standby and hibernate timeouts.)

Performance problems

For best performance with Windows XP, your notebook should have at least 128 MB of memory (RAM).

If the notebook pauses or runs sluggishly

- Press Ctrl+Alt+Del to see if an application is not responding.
- Restart the notebook.
- Certain background operations (such as virus-scanning software) can affect performance and response time.
- Some file browsers respond slowly while processing graphics or waiting for broken network connections to time out.
- If the notebook’s hard disk drive frequently runs (as indicated by the hard drive status light above the keyboard) while the notebook appears to be paused or running slowly,

Troubleshooting and Maintenance

Troubleshooting Techniques

Windows is likely spending excess time writing to its swap file on the notebook's hard disk. If this occurs frequently, consider installing additional memory.

- Check the amount of available free disk space. Delete temporary and unneeded files.

If the notebook stops responding

- Press Ctrl+Alt+Del to end any application that is not responding.
- Reset the notebook—see “To reset your notebook” on page 29.

Power and battery problems

If the notebook turns off immediately after it turns on

- Battery power is probably extremely low. Connect the AC adapter or insert a newly charged battery.

If the notebook keeps beeping

- The notebook beeps repeatedly when the battery is low (you can set this option in Power Options in Control Panel). Save your work immediately, turn off the notebook immediately, and insert a charged battery or connect the AC adapter.

If the battery doesn't charge

- Make sure the AC adapter is securely connected to the power source and the notebook, and that the light on the adapter is on.
- If you're using a power strip, remove the AC adapter from the power strip and plug it directly into a wall outlet.
- Make sure the battery is properly installed and locked in place.
- Move the notebook away from any nearby heat source. Unplug the AC adapter and allow the battery to cool down. If the battery gets too hot, it will not charge properly.
- If available, try another battery and AC adapter.

If the notebook has a short operating time

- Try conserving power using any of the suggestions listed in “To get the most from your batteries” on page 52.
- If you are running an application that has an automatic save feature (such as Microsoft Word), disable this feature or increase the specified save time to reduce hard disk access.

- If the operating time has gradually become shorter and the battery is more than a year or two old, you may need to replace the battery.
- Heavy modem use or PC card use can affect battery operating time.
- The battery gauge may need to be calibrated. Restart the notebook, press F6 when the HP logo appears, and follow the instructions that appear onscreen. This process calibrates the battery, and requires four to five hours to complete. You cannot use the notebook during this time.

If the Time Remaining for the battery seems incorrect

- The Time Remaining is an estimate based on the rate at which the notebook is using power at that instant. So, if you check the Time Remaining while the notebook is using a good deal of power (such as when reading from a CD or DVD), the value will likely show less time remaining than you really have, since you will probably later switch to tasks that require less power.

If the notebook doesn't go on standby as expected

- If you have a connection to another computer, your notebook won't go on standby if the connection is active.
- If the notebook is performing an operation, it normally won't go on standby until the operation is complete.
- Use the BIOS configuration utility to make sure I/O Performance is set to Max Battery Life—see “To run the BIOS configuration utility” on page 102.

If the notebook doesn't automatically hibernate as expected

- Make sure hibernate support is enabled: click Start, Control Panel, Performance and Maintenance, Power Options, then click the Hibernate tab.
Also, check the Power Schemes tab. Make sure the hibernation timeouts for AC power and battery power are not set to Never.
- Use the BIOS configuration utility to make sure I/O Performance is set to Max Battery Life—see “To run the BIOS configuration utility” on page 102.

Printing problems

Hint

You can solve most printing problems by using the printing troubleshooter in Windows Help and Support.

If a printer doesn't print

- Check for printer errors.
- Make sure the printer is on and has paper in it.
- Make sure you are using the correct printer cable or cable adapter, and that the cable is securely connected at both ends.

If the left edge of the printed output is missing

- Certain applications may not work properly with 600-dpi printers. If you're using such a printer, try selecting a compatible printer driver for a 300-dpi printer. For example, if you were using a 600-dpi HP LaserJet printer, you might try using the HP LaserJet IIIsi driver (300 dpi).

Startup problems

If the notebook doesn't respond when you turn it on

- Don't use the touch pad while the notebook is starting up or resuming from standby or hibernation.
- Connect the AC adapter.
- Reset the notebook by using a pin or straightened paper clip to press the system-off switch on the bottom of the notebook. Then press the power button to turn the notebook on.
- If the notebook still doesn't respond, remove the battery and AC adapter, and remove any PC card. Then reset the notebook using the system-off switch on the bottom of the notebook, replace the battery and connect the AC adapter, and turn on the notebook by pressing the power button.
- If you still get no response, call HP for assistance.

If the notebook won't boot from battery power

- Make sure the battery is properly inserted and fully charged. Check the battery's charge by clicking the power icon in the taskbar, or using Power Options in Control Panel.
- If available, try another battery.

If the notebook won't boot from the floppy disk drive

- Make sure the drive is connected correctly—see “To connect a USB floppy disk drive” on page 70.
- Make sure the floppy disk drive is selected as the boot device—see “To change the boot device” on page 30.

Standby and resume problems

If the notebook takes a long time to resume after being on standby

- The notebook can take a minute or longer to resume if a network card is installed. A blinking cursor appears on the display while the system is loading and checking hardware and network connections. As soon as the hardware is reinitialized, the Windows desktop appears.

If you have general problems resuming from standby or hibernation

- Close all applications before going on standby or into hibernation.
- If the problems appeared after you installed new software (including drivers, such as printer drivers), uninstall the software. Contact the software application or device vendor for additional support.

Testing the Hardware

The e-DiagTools hardware diagnostic program included with your notebook provides two levels of testing:

- Automated testing using the basic hardware test.
- Advanced testing using individual hardware tests.

The tests are designed to run after the system reboots. This ensures that the notebook will be in a predictable state, so the diagnostic program can properly test the hardware components. The tests are nondestructive and are intended to preserve the state of the notebook. The notebook reboots when you exit e-DiagTools.

To run the e-DiagTools diagnostic tests

1. Restart the notebook: click Start, Turn Off Computer, Restart.
2. When the HP logo appears, press F10 to start the diagnostic test.
3. When the menu appears, press Enter to run e-DiagTools.

The first time you run the program, you will be prompted to select the language for the program.

4. Follow the prompts to run e-DiagTools.
5. When the Configuration Description appears, verify the list of detected hardware.
6. **Run the basic test.** Press F2 to start the basic hardware test. The results appear when the test is complete.
7. If you intend to exit without running the advanced tests, press F4 and then F7 to view the Support Ticket. Press Esc and then F3 to exit.
8. **Optional: run the advanced tests.** Press F2 to open the advanced test screen.

9. Select and run the appropriate tests using the following keys. Tests are listed only for detected hardware.

Enter	Runs the highlighted test.
F5 or Space	Marks or unmarks the highlighted test.
F6	Marks or unmarks all tests in the current menu.
F7	Marks or unmarks all tests in all menus.
F10	Runs all marked tests.

10. **Save the Support Ticket.** Press T to update and display a Support Ticket containing system and test information. Press Esc to exit.
11. When you have finished running advanced tests, press Esc to exit.
12. **Optional:** to save the Support Ticket to a floppy disk (optional accessory), press F7, then Alt+C.
13. **Exit.** Press F3 and then any key to exit and reboot.
14. **Optional: open the Support Ticket.** In Windows, click Start, All Programs, Hewlett-Packard, Notebook, HP e-DiagTools, e-DiagTools for Windows.
15. Click View to display the Support Ticket.
16. To add information about your problem, click Comments and type the information, then click OK.

To save or print the Support Ticket, click Save As or Print.

To e-mail the Support Ticket to your support agent, click e-Mail. The first time you make an e-mail connection from this program, click Change Settings in the Connect window and enter the settings recommended by your support agent.

e-DiagTools for Windows can also update the version of e-DiagTools on your notebook's hard disk. In e-DiagTools for Windows, use the e-DiagTools menu.

If you have trouble running e-DiagTools from the hard disk, you can also run it from the *Recovery CDs*. Boot from disk 1 and select the diagnostics option.

Configuring Your Notebook

To run the BIOS configuration utility

The BIOS (Basic Input and Output System) configuration utility enables you to make changes to the notebook's system configuration and tailor its operation to your needs.

The settings in the BIOS configuration utility control the notebook's hardware, and so have a fundamental effect on how the notebook operates.

1. Restart the notebook: click Start, Turn Off Computer, Restart.
2. When you see the HP logo, press F2 to enter the BIOS configuration utility.
3. Select the options you want—refer to the listing on the next page.
4. When you finish making changes, press F10 (or select Exit, Save and Reboot).
5. Press Enter to confirm and restart the notebook.

The pointing devices are not active in the BIOS configuration utility, so you'll need to use the keyboard to navigate:

- Press the left and right arrow keys to move from one menu to another.
- Press the up and down arrow keys to move among parameters in a menu.
- Press Enter to open the dialog for the current parameter, or to select the parameter.
- Press Tab or the left and right arrow keys to move among selections in a dialog.
- Press the up and down arrow keys to changes the values for the setting.
- Press Enter to close the dialog and accept the settings.

The following tables describe the settings for the notebook's initial BIOS release. If your BIOS version is different, some settings may differ from those shown, or may be absent.

Startup Menu		Default
Date and Time	Sets the date using mm/dd/yyyy format and the time using 24-hour format. Value set takes effect immediately.	

Boot Device	Shows the order of boot devices, with “+” indicating a device category. Move the entries to change the order. If the notebook has more than one device in a category, you can select the one scanned. Internal LAN appears in the list only if a built-in LAN is present—it provides diskless boot from a network server.	<ol style="list-style-type: none"> 1. Hard Disk 2. CD-ROM/DVD 3. Diskette A 4. Internal LAN
-------------	---	---

Exit Menu		Default
Save and Reboot	Saves changes, then exits and reboots.	
Exit (No Save)	Discards any changes made since last save, then exits and reboots. Does not affect date or time changes.	
Default Settings	Restores default settings and stays in the BIOS configuration utility. Does not affect date or time changes.	

Reinstalling and Updating Software

You can use the *Recovery CDs* provided with your notebook to recover its original factory software.

The *Recovery CDs* also provide Windows drivers specific to your notebook that you can use to configure a custom system. You can find drivers in these locations:

- On your notebook's hard drive under C:\hp\drivers.
- On the *Recovery CDs* under \hp\drivers.
- On the HP Business Support web site (www.hp.com/go/bizsupport). This web site contains the latest updates of software drivers for different operating systems.

To recover the factory installation of your hard disk

You can use your notebook's *Recovery CDs* to reinstall the notebook's original factory software. You can also use this process to create a larger Utility partition on your hard disk, or to create a Utility partition on a new hard disk. (The hidden Utility partition contains the e-DiagTools diagnostic tests and stores hibernation data for operating systems that don't provide hibernation.)

CAUTION

This procedure formats the notebook's hard disk drive and erases all data on the disk. After performing this procedure, you'll need to reinstall your applications.

Do not interrupt this process or disconnect the AC adapter until the process is complete.

1. **Important:** back up all data from your hard disk. The following steps delete all data from the disk.
2. Connect the AC adapter to the notebook.
3. Insert the *Recovery CD* (disk 1) into the notebook's CD/DVD drive. If the notebook is turned off, use a pin or straightened paper clip to press the release switch on the drive door to open it.

4. Turn on or restart the notebook. If the notebook is on, click Start, Turn Off Computer, Restart.
5. When the HP logo appears, press Esc to display the Boot menu.
6. Use the arrow keys to select the CD-ROM/DVD drive as the boot device, and press Enter.
7. When the *Recovery CD* dialog box appears, follow the displayed instructions. If prompted, accept the recommended partition size. If you install the factory software, the recovery process can take up to 15 minutes.

If you want to create the Utility partition without installing the factory software, click Advanced and select not to install the operating system.

If your hard disk is partitioned into several drives, you can install the factory software on drive C without affecting other drives. Click Advanced and select to restore only the C partition.

8. **Important:** when prompted to reboot the notebook, press Ctrl+Alt+Del and follow any instructions that appear.

You can find more details about recovering the factory installation of Windows on the *Recovery CDs*: the file readme.txt is in the root directory of each disk.

To replace damaged *Recovery CDs*

If you lose or damage the *Recovery CDs*, call the HP Customer Care Center for information about obtaining replacements. See “To contact HP for support or service” on page 110 for the phone number.

To update the notebook BIOS

Hewlett-Packard may provide updates to the notebook's BIOS to enhance its capabilities. You can use e-DiagTools for Windows to download and install BIOS updates in your notebook.

CAUTION

Because a BIOS update replaces the previous version, you must follow these instructions exactly, or you risk damaging your notebook. The BIOS update process resets the settings in the BIOS configuration utility.

1. In Windows, exit any programs that are running.
2. Remove any PC card.
3. Connect the AC adapter.
4. Connect any cables or equipment needed to connect to the Internet.
5. Click Start, All Programs, Hewlett-Packard, Notebook, HP e-DiagTools, e-DiagTools for Windows.
6. Click Update, select Download New and click OK. Follow the instructions that appear. **Once the update process begins, do not interrupt it.**

The first time you make an Internet connection from this program, click Change Settings in the Connect window to define your connection settings.
7. When the process is completed, reset the notebook (see page 29).

BIOS updates are also available from the HP Business Support web site (www.hp.com/go/bizsupport). Installation utilities and instructions are provided with the updates.

To update Windows drivers

From time to time, HP releases updated versions of the drivers for your notebook. These updates are intended to fix any problems that could be encountered in the drivers, and to keep your notebook running smoothly. In addition, HP normally provides drivers for other versions of Microsoft Windows, in case you decide to install a different version of Windows.

- Download the latest drivers for your notebook from the HP Business Support web site (www.hp.com/go/bizsupport). Follow the instructions included with the drivers.

HP Service and Support

Getting Assistance for Your Notebook

To get help from HP Instant Support

To get online technical support for your notebook, click Start, Help and Support (or All Programs), HP Instant Support.

To get help from the web

HP has several web sites on the Internet dedicated to providing information about HP notebook computers:

- **HP Business Support web site.** Get e-mail and telephone support information, technical information, and software updates: www.hp.com/go/bizsupport
- **HP Notebook computer web site.** Get the latest information about technical support, plus information about warranty and support programs: www.hp.com/notebooks

To contact HP for support or service

HP Customer Care Centers will assist you free of charge during the term of the warranty (you are responsible for the telephone charges).

During the free assistance period, HP will assist with questions on these topics:

- Applications and operating systems included with your notebook.
- HP-described operation environments and conditions.
- HP accessories, HP upgrades, and basic operation and troubleshooting.

HP will not be able to help with questions on these topics:

- Non-HP hardware, software, operating systems, or usage not intended for nor included (by HP) with the product.
- How to repair the product yourself.
- Product development or custom installations.
- Consulting.

To contact the HP Customer Care Center, visit the HP Business Support web site (www.hp.com/go/bizsupport) under “Contact HP.” You can find information for contacting the Customer Care Center by e-mail, as well as a current list of phone numbers. If your HP notebook product is not normally sold by HP in the country of use, you must call a Customer Care Center that supports your notebook model. Currently, service and support assistance is provided only in the following countries:

Pavilion Notebooks (limited to the following)

- United States: +1 (970) 635-1000

For best service, have as much of the following information as possible when you call.

- Your notebook’s model, serial number, and operating system.
- Any messages displayed when the problem occurred.
- Were there any changes to the notebook, software, related hardware, or accessories before this occurred?
- Can you re-create the problem?

To receive repair service

If the HP notebook product is not normally sold by HP in the country of use, it must be returned for service to a country in which it is sold and supported.

If your notebook is under warranty. To receive warranty repair service for your Pavilion Series notebook, contact the HP Customer Care Center—see “To contact HP for support or service” on page 110. The support technician will help qualify your unit for warranty repair based on the warranty applicable to your unit and original purchase date, and will provide you with repair processes. Warranty service may include the cost of shipping, handling, duties, taxes, freight, or fees to or from the service location.

Note

HP Pavilion notebooks have regional support and service in selected countries. Currently, HP Pavilion notebook PCs are supported only in the country in which they are purchased and marketed. If you are outside the country of purchase, you must cover the cost of shipping your notebook to the appropriate HP authorized repair site.

If you are uncertain about the support, please contact our Customer Care Center—see “To contact HP for support or service” on page 110.

If your notebook is no longer under warranty. Contact the HP Customer Care Center—see page 110 or an HP-Authorized reseller. The support provider will provide details about repair charges and processes.

Note

You are financially responsible for any repairs to your notebook that are not covered by the HP warranty—see the warranty statement on page 114. This includes any repairs required if you damage your notebook—for example, by spilling liquid onto it, dropping it, or breaking the display.

In addition, most DVD drives let you change the region code only a limited number of times (usually no more than four) to allow you to set the proper region code for your area. Please note that when you reach this limit, your last change to the region code will be hard-coded on the DVD drive, and will be permanent. **Your HP warranty does *not* cover the expense of correcting this situation.**

To prepare your notebook for shipment

See “To receive repair service” on the previous page to determine if your notebook must be sent in for service. If it must, prepare it for shipment as follows.

Note

If you have questions about packaging requirements when returning your notebook for repair, contact HP Service and Support—see page 110. If your notebook is not packaged properly, you will be responsible for any damages that occur to it during shipping.

1. **Important. back up your hard disk drive.** The hard disk may need to be replaced or reformatted while your notebook is being repaired.
2. Hewlett-Packard cannot guarantee the return of removable components. Please remove the following before you send your notebook for service:
 - PC cards.
 - AC adapter and power cord.
 - Any removable media, such as CDs, DVDs, or floppy disks.
 - Any hardware not involved in the problem and not requested for repair.
3. When sending your notebook to Hewlett-Packard, please use the original product packaging or other substantial packaging to avoid damage to the notebook in transit. Make sure at least three inches of suitable packaging material surround the notebook.

Your notebook will be returned to you in new packaging.

Note

If the hard disk drive is defective, you will receive a replacement drive that is either unformatted or loaded with software for verification. You should restore the notebook’s original software using your *Recovery CDs* (see “To recover the factory installation of your hard disk” on page 104) or other recovery method.

Hewlett-Packard Limited Warranty Statement

1. HP warrants to you, the end-user customer, that HP hardware, accessories, and supplies will be free from defects in materials and workmanship after the date of purchase, for the period specified in the Warranty Duration table below. HP Pavilion and Omnibook XE Series Notebooks typically come with a standard one-year warranty. Please see the Warranty Duration table for details. If HP receives notice of such defects during the warranty period, HP will, at its option, either repair or replace products which prove to be defective. Replacement products may be either new or equivalent in performance to new.
2. HP warrants to you that HP software will not fail to execute its programming instructions after the date of purchase, for the period specified in the Warranty Duration table below, due to defects in material and workmanship when properly installed and used. If HP receives notice of such defects during the warranty period, HP will replace software which does not execute its programming instructions due to such defects.
3. HP does not warrant that the operation of HP products will be uninterrupted or error free. If HP is unable, within a reasonable time, to repair or replace any product to a condition as warranted, you will be entitled to a refund of the purchase price upon prompt return of the product.
4. HP's limited warranty is valid in any country or locality where HP has a support presence for this product and where HP has marketed this product. The level of warranty service you receive may vary according to local standards. HP will not alter form, fit, or function of the product to make it operate in a country for which it was never intended to function for legal or regulatory reasons.
5. This warranty does not apply to defects resulting from (a) improper or inadequate maintenance or calibration, (b) software, interfacing, parts, or supplies not supplied by HP, (c) unauthorized modification or misuse, (d) operation outside of the published environmental specifications for the product, or (e) improper site preparation or maintenance.

6. TO THE EXTENT ALLOWED BY LOCAL LAW, THE ABOVE WARRANTIES ARE EXCLUSIVE AND NO OTHER WARRANTY OR CONDITION, WHETHER WRITTEN OR ORAL, IS EXPRESSED OR IMPLIED AND HP SPECIFICALLY DISCLAIMS ANY IMPLIED WARRANTIES OR CONDITIONS OF MERCHANTABILITY, SATISFACTORY QUALITY, AND FITNESS FOR A PARTICULAR PURPOSE. Some countries, states, or provinces do not allow limitations on the duration of an implied warranty, so the above limitation or exclusion might not apply to you. This warranty gives you specific legal rights and you might also have other rights that vary from country to country, state to state, or province to province.
7. TO THE EXTENT ALLOWED BY LOCAL LAW, THE REMEDIES IN THIS WARRANTY STATEMENT ARE YOUR SOLE AND EXCLUSIVE REMEDIES. EXCEPT AS INDICATED ABOVE, IN NO EVENT WILL HP OR ITS SUPPLIERS BE LIABLE FOR LOSS OF DATA OR FOR DIRECT, SPECIAL, INCIDENTAL, CONSEQUENTIAL (INCLUDING LOST PROFIT OR DATA), OR OTHER DAMAGE, WHETHER BASED IN CONTRACT, TORT, OR OTHERWISE. Some countries, states or provinces do not allow the exclusion or limitation of incidental or consequential damages, so the above limitation or exclusion may not apply to you.

THE WARRANTY TERMS CONTAINED IN THIS STATEMENT, EXCEPT TO THE EXTENT LAWFULLY PERMITTED, DO NOT EXCLUDE, RESTRICT OR MODIFY AND ARE IN ADDITION TO THE MANDATORY STATUTORY RIGHTS APPLICABLE TO THE SALE OF THIS PRODUCT TO YOU.

Product	Duration of Limited Warranty
HP Notebook with "1YR" or similar mark on serial-number label	1 year, or number of years marked.
HP Notebook with "90D" or similar mark on serial-number label	90 days or number of days marked.
HP Notebook accessories and batteries	1 year.
Non-HP accessories, Non-HP "Distributed by HP" accessories	Not warranted by HP. Refer to manufacturer's warranty.
HP Software, Microsoft Software	90 days.

Reference Information

Hardware Specifications

Because we are constantly improving our products, the specifications shown below are subject to change. For the latest specifications, go to the HP notebook web site (www.hp.com/notebooks).

Note

Technology codes identify different models of a notebook PC. These two-letter codes are found near the serial number on the bottom of the notebook.

Reference Information
Hardware Specifications

Physical Attributes	14.1 in models: 320 x 265 x 34 mm; 6.2 lbs (2.8 kg) minimum. 15.0 in models: 330 x 269 x 35 mm; 6.6 lbs (3.0 kg) minimum.
CPU	Technology code JA: AMD Athlon, up to 1.5 GHz.
Chip Set	Technology code JA: Stepping A3 + VT8231.
RAM	133-MHz SDRAM (PC133). Maximum memory upgrade to 1 GB by two 512-MB SODIMM (144-pin/3.3 V) modules in two 1.25-in slots.
Mass Storage	9.5-mm, 2.5-in hard disk drive.
Optical drive	DVD-ROM, 12.7mm OR DVD/CD-RW, 12.7 mm.
Display	14.1-in XGA (1024x768) TFT LCD. 15.1-in XGA (1024x768) TFT LCD.
Graphics	Integrated AGP, 3D embedded in VIA ProSavage.
Video chip	Integrated AGP, 3D embedded in VIA ProSavage.
Keyboard and Pointing Devices	87-key spill-resistant QWERTY keyboard with 101/102 key emulation. Embedded numeric keypad. 12 function (Fn) keys. Touch pad with integrated scroll pad, on-off button, and indicator. Left and right click buttons.
Audio	Two stereo speakers. Color-coded jacks: headphone-out (lime green) and microphone-in (pink).
Power	Rechargeable lithium-ion battery (55 W). Low-battery warning. Suspend/resume capability. AC adapter (DC-in) jack. Universal AC adapter: 100–240 Vac (50/60 Hz) input, 19 Vdc output, 75 W.
I/O Ports	25-pin bi-directional high-speed ECP/EPP parallel (burgundy). 15-pin external monitor (VGA) video out port (blue). Two universal serial bus (USB) ports. IEEE 1394 port (selected models). Built-in RJ-11 modem, supporting Wake up on Ring# from D3 (hot) with AC-in. Built-in RJ-45 LAN
Expandability	One Type II or Type III 16-/32-bit PCMCIA slot.
Options	128/256/512-MB PC133 SODIMM: 3.3 V, 144-pin, SDRAM.
Environment	Operating temperature: 0 to 40 °C (32 to 104 °F). Storage temperature: –20 to 65 °C (–4 to 149 °F). Operating humidity: 10% to 90% RH (0 to 40 °C). Operating altitude: up to 3,000 m (10,000 ft) at 25 °C (77 °F). Storage altitude: up to 12,000 m (40,000 ft).

Reference Information

Modem Reference Information

Modem Reference Information

If your notebook has a built-in modem, you can customize the operation of the modem using AT commands and S-registers. You can do this from Phone and Modem Options in Control Panel, from most communications software, or by using terminal mode in your software. See “To change your modem settings” on page 60.

Note

You should have a good understanding of modems and how they operate before you change default settings.

This section contains summary information about AT commands, S-registers, and selected result codes for the built-in modem (with a Conexant chip).

AT commands (Conexant)

All listed AT commands must be preceded by the characters “AT” (except for the command “A/”). The commands can be entered in upper or lower case.

Note

Many commands can be used as queries by entering “?” as the argument.

Command	Function (Conexant)
A	Go off-hook and attempt to answer a call.
A/	Re-execute command (not preceded by AT).
Dn	Dial modifier: 0–9, A–D =DTMF digits; L=redial last number; P=pulse dialing; T=tone dialing; W=wait for dial tone; * (“star”); # (“pound sign”); +=!flash; @=wait for silence; \$ or &=wait for credit card dialing tone; ;=return to command state; ‘=dial pause; ^=toggle calling tone. Parentheses, hyphens, and spaces can be used to format dial string and have no other effect.
E0	Turn off command echo.
E1	Turn on command echo (default).
H0	Initiate hang-up sequence.
H1	If on-hook, go off-hook and enter command mode.
I0	Report product code.
I1	Report LSB of stored checksum.
I2	Report “OK”.
I3	Report identification codes.
I4	Report product description.
I5	Report country code parameter.
I6	Report modem data pump model and internal code revision.
I7	Report modem data pump model and internal code revision.

Modem Reference Information

Command	Function (Conexant)
I8	Report "OK".
I9	Report country.
L <i>n</i>	Set speaker volume: 0=off, 1=low (default), 2=medium, 3=high.
M <i>n</i>	Activate speaker: 0=off, 1=on during handshaking and off when receiving carrier (default), 2=always on, 3=off when dialing and receiving carrier, on when answering.
N0 or N1	Included for compatibility only; returns result code.
O <i>n</i>	0=go on-line, 1=go on-line and initiate retrain sequence.
P	Force pulse dialing.
Q <i>n</i>	0=enable result codes to DTE (default), 1=disable.
S <i>n</i>	Select S-register <i>n</i> as default.
S <i>n</i> = <i>v</i>	Set default S-register <i>n</i> to value <i>v</i> .
T	Force DTMF dialing.
V <i>n</i>	Report result codes: 0=short form (terse), 1=long form (verbose) (default).
W0	Report DTE speed (default).
W1	Report line speed, error correction protocol, and DTE speed.
W2	Report DCE speed.
W3	Report DCE speed and error correction protocol.
X0	Report CONNECT result code on connecting. Dial tone and busy detection not reported.
X1	Report CONNECT <text> result code on connecting. Dial tone and busy detection not reported.
X2	Report CONNECT <text> result code on connecting. Dial tone and busy detection not reported.
X3	Report CONNECT <text> result code on connecting. Dial tone not reported, busy signal reported if detected.
X4	Report CONNECT <text> result code on connecting. Dial tone and busy signal reported if detected (default).
Z	Reset to default configuration.
+DR: <i>a</i>	Select error control protocol: NONE=no data compression, V42B=42bis in both directions, ALT=MNP 5 compression.
+DR= <i>n</i>	0=disables extended format "+DR:" intermediate result code, 1=enables.
+DS= <i>a,b,c,d</i>	Controls V.42bis data compression function (<i>b</i> , <i>c</i> , and <i>d</i> are optional): <i>a</i> sets direction(s) of data compression function, seen by DTE: 0=negotiated, no compression; 3=both directions (default). <i>b</i> =0 specifies modem does not disconnect if V.42bis is not negotiated by remote modem as specified by <i>a</i> . <i>c</i> sets maximum number of dictionary entries (2048) that should be negotiated. <i>d</i> sets maximum string length (32 bytes) to be negotiated.
+DS44= <i>a,b,c,d,e,f,g,h,i</i>	Controls V.44 data compression function (<i>b</i> , <i>c</i> , <i>d</i> , <i>e</i> , <i>f</i> , <i>g</i> , <i>h</i> , and <i>i</i> are optional): <i>a</i> sets direction(s) of data compression function, seen by DTE: 0=negotiated, no compression; 1=transmit only; 2=receive only; 3=both directions (default). <i>b</i> specifies whether modem disconnects if V.44 not negotiated remote DCE as specified in <i>a</i> : 0=do not disconnect (default), 1=disconnect. <i>c</i> : 0=stream method (default), 1=packet method, 2=multi=packet method. <i>d</i> (256 to 2048) sets maximum codewords to be negotiated in transmit direction (default=2048). <i>e</i> (256 to 2048) sets maximum codewords to be negotiated in receive direction (default=2048). <i>f</i> (32 to 255) sets maximum string length to be negotiated in transmit direction (default=32). <i>g</i> (32 to 255) sets maximum string length to be negotiated in receive direction (default=32). <i>h</i> (2048 to 4096) sets maximum size of history buffer to be negotiated in transmit direction (default=4096). <i>i</i> (2048 to 4096) sets maximum size of history buffer to be negotiated in receive direction (default=4096).

Reference Information

Modem Reference Information

Command	Function (Conexant)
+ESA= <i>a,b,c,d,e,f,g,h</i>	Controls operation of synchronous access mode: <i>a</i> =0 specifies in transparent sub-mode, modem transmits 8-bit SYN sequence on idle. <i>b</i> =0 specified in framed sub-mode, modem transmits HDLC flags on idle (default and fixed). <i>c</i> =0 specifies in framed sub-mode, modem transmits abort on underrun in middle of frame (default); <i>c</i> =1 specifies in framed sub-mode, modem transmits flag on underrun in middle of frame, notifies DTE. <i>d</i> : not to be commanded. <i>e</i> =0 specifies CRC generation and checking disabled (default and fixed). <i>f</i> =0 specifies NZRI encoding and decoding disabled (default and fixed). <i>g</i> =255 sets the octet value used in character-oriented framing. <i>h</i> : not to be commanded.
+GCAP	Transmit text listing commands that provide additional modem capabilities.
+GCI= <i>n</i>	Set country of installation using 8-bit country code from Annex A of T.35.
+GMI	Report modem manufacturer.
+GMM	Report modem model.
+GMR	Report modem version, revision, or date.
+GOI	Transmit text identifying the device.
+GSN	Report modem model serial number.
+IFC= <i>n,m</i>	Set operation of local flow control between DTE and modem. <i>n</i> =method DTE uses to control data flow from modem: 0=none, 1=XON/XOFF on transmitted data, 2=Circuit 133 (Ready for Receiving) (default). <i>m</i> =method modem uses to control data flow from DTE: 0=none, 1=XON/XOFF on received data, 2=CTS/RTS (default).
+ILRR= <i>n</i>	Report local port rate: 0=disable, 1=enable.
+IPR= <i>n</i>	Set data rate at which the modem accepts commands when connected: 0 (allows operation only at rates automatically detectable by modem), 2400, 4800, 9600, 19200, 38400, 57600, or 115200.
+ITF= <i>a,b,c</i>	Sets transmit flow control thresholds (<i>b</i> and <i>c</i> are optional): <i>a</i> (20 to 7000) sets threshold (octets) above which modem generates flow-off signal in synchronous access mode (default=128). <i>b</i> (10 to 5000) sets threshold (octets) below which modem generates flow-on signal in synchronous access mode (default=64). <i>c</i> =0 (fixed).
+PCW= <i>n</i>	Set modem behavior with call waiting: 1=request modem-on-hold and collect caller ID information, 2=hang up, 3=ignore call waiting.
+PIG= <i>n</i>	0=enable PCM upstream negotiation, 1=disable (default).
+PMH= <i>n</i>	Set modem-on-hold: 0=enabled in V.92 mode (default), 1=disabled.
+PMHF	Initiate flash hook sequence when in modem-on-hold procedure.
+PMHR= <i>n</i>	Request modem to initiate or confirm modem-on-hold (MOH) procedure and timeout: 0=V.92 modem-on-hold request denied or unavailable, 1 to 13 grant MOH with timeout (1=10 sec, 2=20 sec, 3=30 sec, 4=40 sec, 5=1 min, 6=2 min, 7=3 min, 8=4 min, 9=6 min, 10=8 min, 11=12 min, 12=16 min, 13=indefinite).
+PMHT= <i>n</i>	Set whether modem grants modem-on-hold (MOH) request, and MOH timeout: 0=deny V.92 modem-on-hold request (default), 1 to 13=grant MOH with timeout (1=10 sec, 2=20 sec, 3=30 sec, 4=40 sec, 5=1 min, 6=2 min, 7=3 min, 8=4 min, 9=6 min, 10=8 min, 11=12 min, 12=16 min, 13=indefinite).
+PQC= <i>n</i>	Use Short Phase startup procedures: 0=enable V.92 Short Phase 1 and 2 (default), 1=enable Short Phase 1 only, 3=disable.
+PSS= <i>n</i>	0=modems decide whether to use short startup procedures, 2=use full startup procedures on all subsequent connections.
+VCID= <i>n</i>	Set caller ID reporting: 0=disable (default), 1=enable with formatted presentation, 2=enable with unformatted presentation.
+VRID= <i>n</i>	Report caller ID: 0=use formatted presentation, 1=use unformatted presentation.
-QCPC	Use full startup procedures on next connection, then select startup procedure defined by +PQC.

Modem Reference Information

Command	Function (Conexant)
-QCPS= <i>n</i>	0=do not allow modem to save generated quick-connect profile, 1=allow (default).
&C <i>n</i>	Set RLSD: 0=always on, 1=follow carrier state (default).
&D <i>n</i>	0=ignore DTR; 1=upon on-to-off transition, enter online command state and issue OK result code; call remains connected; 2=upon on-to-off transition clear call, discard untransmitted data according to +ETBM.
&E <i>n</i>	0=disable line quality monitor, auto-retrain, and auto-rate renegotiation; 1=enable line quality monitor, auto-retrain, and auto-rate renegotiation (default).
&F0	Restore factory configuration.
&G <i>n</i>	Included for compatibility only; no effect (returns OK).
&K <i>n</i>	Set DTE/DCE flow control: 0=disable, 3=enable RTS/CTS DTE/DCE flow control (default), 4=enable XON/XOFF DTE/DCE flow control, 5 and 6 included for compatibility only (no effect, returns OK).
&M <i>n</i>	Included for compatibility only; no effect (returns result code).
&P <i>n</i>	Set pulse dial (pps) with make/break: 0=10 pps with 39%–61% make/break (default), 1=10 pps with 33%–67% make/break, 2=20 pps with 39%–61% make/break, 3=20 pps with 33%–67% make/break.
&Q5	Select asynchronous operation in error correction mode.
&Q <i>n</i>	(<i>n</i> =0–3, 6) Select asynchronous operation in normal mode (speed buffering).
&T0	Terminate any test in progress.
&T1	Initiate local analog loopback.
&V	Display current configuration and stored profiles.
%TT <i>n</i>	PTT testing of signal level: 00–09=DTMF dial 0–9, 0A=DTMF *, 0B=DTMF #, 0C=DTMF A, 0D=DTMF B, 0E=DTMF C, 0F=DTMF D, 10=V.21 Channel 1mark symbol, 11=V.21 Channel 2mark symbol, 12=V.23 Channel 1mark symbol, 13=V.23 Channel 2mark symbol, 14=Bell103 Channel 1mark symbol, 15=Bell103 Channel 2mark symbol, 20=V22Org, 21=V22Ans, 22=Bell212Org, 23=Bell212Ans, 24=V22BisOrg, 25=V22BisAns, 26=V32@4800, 27=V32@7200, 28=V32@9600, 29=V.32Bis@12000, 2A=V32Bis@14400, 30=Silence, 31=2100Hz MISC, 33=1300Hz MISC, 34=1100Hz MISC, 40=Reserved, 41=V27@2400 FAX, 42=V27@4800 FAX, 43=V29@7200 FAX, 44=V29@9600 FAX, 45=V17@7200LT FAX, 46=V17@7200ST FAX, 47=V17@9600LT FAX, 48=V17@9600ST FAX, 49=V17@12000LT FAX, 4A=V17@12000ST FAX, 4B=V17@14400LT FAX, 4C=V17@14400ST FAX. 5 <i>abc</i> : <i>a</i> =bit rate (0=2400, D=33600), <i>b</i> =V.34 symbol rate (0=2400, 5=3429), <i>c</i> =pre-emphasis filter (0 to A).
When modem receives break from the remote modem:	
\N0	Select normal speed buffered mode.
\N1	Select normal speed buffered mode.
\N2	Select reliable (error-correction) mode.
\N3	Select auto reliable mode.
\N4	Force LAPM mode.
\N5	Force MNP mode.
+MCR	Report carrier.
+MMR	Report transmit and receive rates.
+MR=0	Disable reporting of modulation connection.
+MR=1	Enable reporting of modulation connection (+MCR: and +MRR: are transmitted) (default).
+MR=2	Enable reporting of modulation connection (+MCR: and Receive Rate Only: are transmitted).

Reference Information

Modem Reference Information

Command	Function (Conexant)
+MS= <i>a,b,c,d,e,f</i>	Select modulation (<i>b, c, d, e, and f</i> are optional). <i>a</i> is the carrier (allowable rates in parentheses): B103 (300), B212 (1200 Rx/75 Tx or 75 Rx/1200 Tx), V21 (300), V22 (1200), V22B (1200/2400), V23C (1200), V32 (4800/9600), V32B (4800–14400), V34 (2400–33600), K56 (32000–56000), V90 (28000–56000), V92 (downstream: 28000–56000; upstream: 24000–48000). <i>b</i> is automode: 0=disabled, 1=enabled (default). <i>c</i> is minimum transmit (Tx) rate (bps). <i>d</i> is maximum transmit rate (bps). <i>e</i> is minimum receive (Rx) rate. <i>f</i> is maximum receive rate (bps).
+WS= <i>n</i>	Set PDC mode: 1=disable (default), 20=enable.

ECC Commands

% <i>Cn</i>	Set data compression: 0=disable, 1=enable V.42 bis and MNP 5, 2=enable V.42 bis and MNP 5, 3=enable V.42 bis and MNP 5 (default).
+EB= <i>a,b,c</i>	Select break handling (<i>b</i> and <i>c</i> are optional): <i>a</i> =0 — break is ignored. <i>b</i> =0 — transmitted V.42 L-SIGNAL will not indicate break signal length. <i>c</i> =0 — break is not delivered to DTE.
+EFCS=0	Select 16-bit FCS specified in V.42.
+ER: <i>a</i>	Select error control protocol: NONE=error control not in use, LAPM=V.42 LAPM protocol, ALT=MNP.
+ER= <i>n</i>	Error control reporting: 0=disable, 1=enable.
+ES= <i>a,b,c</i>	Select error control and synchronous mode (<i>b</i> and <i>c</i> are optional). <i>a</i> is requested mode when modem is originator: 0=initiate call with direct mode, 1=initiate call with normal mode, 2=initiate V.42 without detection phase, 3=initiate V.42 with detection phase (default), 4=initiate MNP, 6=initiate V.80 synchronous access mode when connection is completed. <i>b</i> specifies fallback mode when modem is originator: 0=LAPM, MNP, or normal mode error control optional (default); 1=LAPM, MNP, or direct mode error control optional; 2=LAPM or MNP error control required; 3=LAPM error control required; 4=MNP error control required. <i>c</i> specifies fallback mode when modem is answerer or specifies V.80 synchronous access mode: 1=error control disabled, use normal mode; 2=LAPM, MNP, or normal mode error control optional (default); 3=LAPM, MNP, or direct mode error control optional; 4=LAPM or MNP error control required; 5=LAPM error control required; 6=MNP error control required; 8=initiate V.80 synchronous access mode when connection complete.
+ESR=0	Disable selective repeat option in V.42.
+ETBM= <i>a,b,c</i>	Handle data remaining in modem buffers on call termination (<i>b</i> and <i>c</i> are optional): <i>a</i> =0 — disconnect occurs immediately and buffered transmit data is discarded. <i>b</i> =0 — disconnect occurs immediately and buffered receive data is discarded. <i>c</i> =0 — modem does not attempt to deliver buffered data and discards data.

FAX Class 1

+FAE= <i>n</i>	Data/fax auto answer: 0=disable (default), 1=enable.
+FAR= <i>n</i>	0=disable adaptive reception (default), 1=enable.
+FCL= <i>n</i>	Set loss-of-carrier delay in units of 100 ms (<i>n</i> =0 to 255).
+FCLASS= <i>n</i>	Set active service class: 0=data mode (default), 1=Fax Class 1, 1.0=Fax Class 1.0 mode, 8=voice mode.
+FIT= <i>n,a</i>	Set DTE inactivity timeout <i>n</i> seconds after which modem goes on-hook (<i>a</i> =0) or DCE goes on hook (<i>a</i> =1).
+FLO= <i>a</i>	Set flow control type: 0=XON/XOFF and RTS/CTS flow control turned off; 1=XON/XOFF flow control in either direction; 2=RTS for flow control of modem by DTE, and CTS for flow control of DTE by modem.
+FMI	Report modem manufacturer.
+FMM	Report modem model.

Modem Reference Information

Command	Function (Conexant)
+FMR	Report modem version, revision, or date.
+FPR= <i>n</i>	Set DTE/modem interface rate in bits/sec: 0=automatic detection (default).
+FRH= <i>n</i>	Receive data with HDLC framing.
+FRM= <i>n</i>	Receive data.
+FRS= <i>n</i>	Receive silence, <i>n</i> ×10 ms.
+FTH= <i>n</i>	Transmit data with HDLC framing.
+FTM= <i>n</i>	Transmit data.
+FTS= <i>n</i>	Stop transmission and wait, <i>n</i> ×10 ms.
Voice Commands	
+FCLASS=8	Select voice mode.
+VDR= <i>a,b</i>	Set report ring cadence and timing of RING event code: <i>a</i> =0 disables ring cadence reporting, <i>a</i> =1 enables. <i>b</i> sets report content: 0=DROF and DRON messages only.
+VDT= <i>a,b</i>	Set report control tone cadence: <i>a</i> =0 disables ring cadence reporting, <i>a</i> =1 enables. <i>b</i> =0 reports CPOF and CPON messages only.
+VDX= <i>a</i>	Select speakerphone half-duplex (<i>a</i> =0) or full duplex (<i>a</i> =1).
+VGM= <i>n</i>	Set microphone gain of speakerphone function (0 to 255).
+VGR= <i>n</i>	Set gain for received voice samples (0 to 255).
+VGS= <i>n</i>	Set speaker gain of speakerphone function (0 to 255).
+VGT= <i>n</i>	Set volume (120 to 135).
+VIP	Initialize all voice parameters to defaults.
+VIT= <i>n</i>	Set initial value for DTE/modem inactivity timer (0 to 255 seconds).
+VLS= <i>n</i>	Select sources/destinations for analog data.
+VNH= <i>n</i>	Set automatic hangups: 0=enable, 1=disable, 2=disable automatic hangups in non-voice modes.
+VPR= <i>n</i>	Set DTE/modem interface rate (0=autobaud).
+VRA= <i>n</i>	Set delay between ringbacks before modem assumes remote station is off hook (0 to 255 x 0.1 sec).
+VRN= <i>n</i>	Set delay between ringbacks before modem assumes remote station is off hook (0 to 60 sec).
+VRX= <i>n</i>	Start voice reception: 0=start without periodic tone production, 1=start with periodic tone production.
+VSD= <i>a,b</i>	Set silence detection sensitivity and required period of silence before modem reports silence at end of voice receive.
+VSM= <i>a,b,c,d</i>	Set voice and silence compression methods, and voice sampling rate.
+VSP= <i>a</i>	Disable (<i>a</i> =0) or enable (<i>a</i> =1) speakerphone.
+VTD= <i>n</i>	Set beep duration (1 to 500 x 0.01 sec).
+VTR	Start voice transmission and reception.
+VTS= <i>string</i>	Send voice tones.
+VTX	Start voice transmission.
AT* Commands	
*B	Display black-listed numbers.
*D	Display delayed numbers.

Reference Information

Modem Reference Information

S parameters (Conexant)

Register	Function	Range/units	Default
S0	Number of rings to auto-answer.	0–255/rings	0
S1	Ring counter.	0–255/rings	0
S2	Escape character.	0–255/ASCII	43
S3	Line termination character.	0–127/ASCII	13
S4	Response formatting character.	0–127/ASCII	10 (line feed)
S5	Command line editing character.	0–32/ASCII	8 (backspace)
S6	Wait time for dial tone.	2–255/sec	2
S7	Wait time for carrier.	1–255/sec	50
S8	Pause time for dial delay modifier.	0–255/sec	2
S10	Carrier loss disconnect time.	1–255/.1 sec	14 (1.4 sec)
S11	DTMF tone duration.	50–255/.001 sec	95 (95 msec)
S12	Escape prompt delay.	0–255/.02 sec	50 (1 sec)
S18	Test timer.	0–255/sec	0
S29	Flash dial modifier time.	0–255/10 msec	70 (700 msec)
S30	Disconnect inactivity timer.	0–255/10 sec	0
S46	Data compression control.	136 (error correction w/o compression) or 138 (error correction & compression)	138
S95	Extended result code messages control.		0

Selected result codes (Conexant)

Code	Meaning
0	OK
1	CONNECT
2	RING
3	NO CARRIER
4	ERROR
5	CONNECT 1200
6	NO DIAL TONE
7	BUSY
8	NO ANSWER
24	DELAYED
32	BLACKLISTED
33	FAX
35	DATA
83	LINE IN USE

Safety Information

Power cords

The power cord supplied with the notebook's AC adapter should match the plug and voltage requirements for your local area. Regulatory approval for the AC adapter has been obtained using the power cord for the local area. However, if you travel to a different area or need to connect to a different outlet or voltage, you should use one of the power cords listed below. To purchase a power cord (including one for a country not listed below) or a replacement AC adapter, contact your local Hewlett-Packard dealer or Sales office. For any power cord with a fused plug, if you have to replace the fuse, be sure to install an approved fuse.

Country/Region	Rated Voltage and Current	HP Part Number
Canada Mexico Philippines Taiwan United States	125 Vac (3 A)	8120-6313
Europe Egypt Israel Saudi Arabia	250 Vac (2.5 A)	8120-6314
Hong Kong Singapore United Kingdom	250 Vac (2.5 A)	8120-8699
Australia New Zealand	250 Vac (2.5 A)	8120-6312
Japan	125 Vac (3 A)	8120-6316
India	250 Vac (2.5 A)	8121-0702
South Africa	250 Vac (2.5 A)	8120-6317
Argentina	250 Vac (2.5 A)	8120-8367
Chile	250 Vac (2.5 A)	8120-8452
People's Republic of China	250 Vac (2.5 A)	8120-8373

Ergonomics

WARNING

Improper use of keyboards and other input devices has been associated with ergonomic injury. For information about reducing your risk, see “Working in Comfort” in the online HP Library, or visit our ergonomics web site, www.hp.com/ergo.

Battery safety

Note

Use only the battery that came with your notebook, or an HP-approved replacement—see “To buy accessories” on page 13.

- To avoid risk of fire, burns, or damage to your battery, do not allow a metal object to touch the battery contacts.
- Do not disassemble the battery. There are no serviceable parts inside.
- Handle a damaged battery with extreme care. If you come in contact with the electrolyte, wash the exposed area with soap and water. If it contacts the eye, flush the eye with water for 15 minutes and seek medical attention.
- Do not expose the battery to storage temperatures above 60° C (140° F).
- Do not charge the battery if the ambient temperature exceeds 45° C (113° F).
- Replace only with the same or equivalent type battery recommended by the manufacturer. To obtain a replacement battery, contact your local dealer or HP sales office.
- Before discarding a battery, contact your local waste disposal provider regarding local restrictions on the disposal or recycling of batteries.
- Do not dispose of the battery in fire or water.
- The battery is suitable for use only with compatible HP notebook models. For more information, see “To contact HP for support or service” on page 110.



Laser safety

The CD-ROM and DVD drives used with the HP notebook PC are certified as Class 1 laser devices according to the U.S. Department of Health and Human Services (DHHS) Radiation Performance Standard and International Standards IEC 825 / IEC 825-1 (EN60825 / EN60825-1). These devices are not considered harmful, but the following precautions are recommended:

- Ensure proper use by reading and following the device's instructions carefully.
- If the unit requires service, contact an authorized HP representative—see “To contact HP for support or service” on page 110.
- Do not attempt to make any adjustment of the unit.
- Avoid direct exposure to the laser beam—do not disassemble the drive.

CLASS 1 LASER PRODUCT LASER KLASSE 1

Regulatory Information

This section presents information that shows how the HP notebook PC complies with regulations in certain regions. Any modifications to the computer not expressly approved by Hewlett-Packard could void the authority to operate the HP notebook PC in these regions.

U.S.A.

This computer has been tested and found to comply with the limits for a Class B digital device, pursuant to Part 15 of the FCC Rules. These limits are designed to provide reasonable protection against harmful interference in a residential installation.

This computer generates, uses, and can radiate radio frequency energy. If not installed and used in accordance with the instructions, it may cause harmful interference to radio communications. However, there is no guarantee that interference will not occur in a particular installation. If this computer does cause harmful interference to radio or television reception (which can be determined by removing the unit's batteries and AC adapter), try the following:

- Reorienting or relocating the receiving antenna.
- Relocating the computer with respect to the receiver.
- Connecting the computer's AC adapter to another power outlet.

Connections to Peripheral Devices

To maintain compliance with FCC Rules and Regulations, use properly shielded cables with this device.

For more information, consult your dealer, an experienced radio/television technician, or the following booklet, prepared by the Federal Communications Commission: *How to Identify and Resolve Radio-TV Interference Problems*. This booklet is available from the U.S. Government Printing Office, Washington, DC 20402, Stock Number 004-000-00345-4. At the first printing of this manual, the telephone number was (202) 512-1800.

Declaration of Conformity (U.S.A.)

Responsible Party: Hewlett-Packard Company
Manager of Corporate Product Regulations
3000 Hanover Street
Palo Alto, CA 94304, U.S.A.
+1 (650) 857-1501

declares that the product

Trade name: Hewlett-Packard Company

Product name: Notebook PC

Model Number(s): Pavilion ZE1000 series Notebook PC

complies with Part 15 of the FCC Rules.

Operation is subject to the following two conditions:

1. This device may not cause harmful interference, and
2. This device must accept any interference received, including interference that may cause undesired operation.

Index

A

AC adapter

- compatibility, 23
- connecting, 23
- requirements, 127

accessories, 14

AOL

- as your ISP, 58
- connecting to, 58
- disconnecting, 59
- e-mail, 60

Applications key, 34

AT commands, 60, 120

audio

- connecting devices, 71
- troubleshooting, 81

auto/airline adapter, 14

B

battery

- best use of, 53
- charge light, 51
- charging, 52
- checking status, 51
- installing, 22
- low power warning, 52
- maintaining capacity, 53
- operating time, 52, 53, 96
- recharging, 22
- removing, 22
- safety, 128
- saving power, 52, 53. *See Reference Guide*
- status light, 19
- troubleshooting, 96

BIOS

- configuration utility, 102
- updating, 106

boot device order, 30

brightness

- adjusting, 32, 35

C

Caps Lock status light, 20

- inserting disks, 36
- removing disks, 36

, 20

troubleshooting, 82

CDs

- creating or copying, 39
- recommended media, 39

charging batteries, 52

cleaning the notebook, 46

click buttons

- configuring, 31
- using, 30, 31

clicking items, 31

configuring

- touch pad, 31

connecting

- audio devices, 71
- external monitor, 72
- floppy drive, 70
- LAN, 63
- modem, 56
- parallel device, 69
- USB device, 69

copyrights, 2

cursor (pointer), 31

D

data

- protecting, 45

default settings, 28

devices (external)

- parallel, 69
- USB, 69

diagnostics, 100

dial-in network connection, 59

display

- adjusting colors, 35
- brightness, 32, 35, 45, 52
- extending life, 45
- external, 72
- quality, 85
- resolution, 35
- settings, 35
- size of objects in, 35
- timeouts, 45
- troubleshooting, 84
- turning off, 50

dragging items, 31

drivers

- downloading, 107

DVD drive

- setting region code, 38
- troubleshooting, 82

DVDs

- checking play status, 38
- playing, 38
- region code, 38

E

e-DiagTools for Windows, 100, 101

e-mail

- HP Customer Care, 111

ergonomics, 21, 42

external components

- connecting, 68
- monitor, 72

external mouse

- configuring, 31

F

F10 (diagnostics), 100

factory software

- recovering, 104

Fax Console, 56, 61

faxes

- receiving, 62
- sending, 62
- viewing, 62

file transfers

- and power settings, 64, 67

files

- recovering, 104

, 20

troubleshooting, 85

USB connection, 70

Fn key

- + Backspace (mute function), 36
- + F1 (decrease brightness), 32
- + F10 (Scroll Lock), 32
- + F2 (increase brightness), 32
- + F5 (display select), 32
- + F8 (keypad), 32, 34
- + F9 (Num Lock), 32
- + Home (mute), 32
- + Page Down (decrease volume), 32

- + Page Up (increase volume), 32
 - external keyboards, 32
 - temporary keypad, 34
- H**
- caring for, 44
 - checking, 45
 - holder, 77
 - protecting, 44
 - replacing, 76
 - , 20
 - troubleshooting, 86
 - Utility partition, 75, 76
 - hardware
 - testing, 100
 - Hewlett-Packard support, 80
 - hibernation (power mode)
 - enabling, 49
 - entering, 28, 50
 - low battery, 52
 - power status light, 19, 20
 - resuming from, 48, 50
 - timeout, 28
 - timeouts, 49
 - when used, 48, 50
 - hot keys, 32
 - HP Customer Care
 - contact by e-mail, 111
 - telephone numbers, 111
 - web site, 15, 94
 - HP Instant Support, 80, 110
 - HP Library, 14
 - HP Notes, 14
- I**
- Internet
 - connecting to, 26, 58
 - disconnecting from, 59
 - Internet Explorer, 56, 58
 - Internet Service Provider, 56
 - inventory, 13
- K**
- Kensington lock
 - attaching, 40
 - keyboard
 - embedded keypad, 34
 - ergonomic precautions, 21
 - external, 32
 - num lock, 34
 - status lights, 20
 - troubleshooting, 87
 - keypad (embedded), 34, 35
- L**
- LAN
 - connecting to, 63
 - port indicator lights, 63
 - troubleshooting, 88
 - laser safety, 129
 - lid
 - options when closing, 50
 - lights
 - LAN port, 63
 - status, 20
 - locking (cable), 40
- M**
- maintenance, 28
 - memory
 - installing, 74
 - removing, 74
 - troubleshooting, 89
 - modem
 - AT commands, 60, 120
 - connecting, 24, 56
 - connecting to Internet with, 58
 - dial-in connection, 59
 - faxing, 61
 - sending e-mail with, 60
 - settings, 60
 - software, 56
 - speed, 56
 - troubleshooting, 90, 91
 - monitor
 - external, 72
 - resolution, 72
 - mouse
 - troubleshooting, 87
 - movies (DVD), 38
 - mute function, 36
- N**
- network
 - connecting to, 63
 - dialing in to, 59
 - Norton AntiVirus, 41
 - notebook
 - caring for, 44. *See Reference Guide*
 - cleaning, 46
 - default settings, 28
 - overheating, 86
 - ports, 68, 71
 - protecting, 74
 - registering, 26
 - resetting, 29
 - resuming, 28
 - testing, 100
 - timeouts, 48, 49, 97
 - turning on and off, 25, 28
 - Num Lock
 - status light, 20
- O**
- One-Touch buttons
 - onscreen labels, 33
 - troubleshooting, 92
 - using, 32
 - Outlook Express, 56, 60
- P**
- parallel device, connecting, 69
 - parallel port
 - troubleshooting, 93
 - partition (Utility), 75, 76
 - password
 - creating, 40
 - when resuming, 40
 - PC card
 - inserting, 66
 - removing, 66
 - saving power, 53
 - tested, 67
 - troubleshooting, 94
 - using, 66
 - performance troubleshooting, 95
 - phone line
 - connecting, 24
 - requirements, 24
 - pointing devices
 - configuring, 31
 - using, 31
 - ports
 - notebook, 68, 71
 - power
 - connecting AC, 23
 - saving, 52, 53. *See Reference Guide*
 - standby, 50
 - status light, 19, 20
 - troubleshooting, 96
 - power button
 - options, 50
 - using, 25
 - power cords, 127
 - power management
 - automated, 48

- manual, 50
- schemes, 49
- setting properties, 49
- power modes
 - entering, 28
 - hibernation, 28
 - standby, 28
- printing
 - compatible printers, 69
 - parallel connection, 69
 - troubleshooting, 97
- protection
 - Kensington lock, 40
- Q**
- Quick Start* sheet, 14
- R**
- RAM**
 - installing, 74
 - removing, 74
- receiving faxes, 61
- recovering
 - hard disk, 104
- Recovery CDs*
 - diagnostics, 101
 - using, 104
- region code (DVDs)
 - setting, 38
- registration, 26
- regulatory information, 130
- reinstalling Windows, 104
- repair service
 - obtaining, 80, 113
 - shipment, 113
- resetting
 - notebook, 29
- resume
 - troubleshooting, 99
- S**
- safety
 - battery, 128
 - laser, 129
 - power cords, 127
- saving battery power, 52, 53
- Pad Lock
 - status light, 20
- , 31
- security
 - anti-virus software, 41

- Kensington lock, 40
- selecting items, 31
- sending faxes, 61
- service (repair), 80
- software
 - pre-installed, 13
- sound
 - muting, 36
- standby (power mode)
 - and display life, 45
 - entering, 50
 - password on resuming, 40
 - power status light, 19, 20
 - resuming from, 28, 48, 50
 - timeout, 28, 49
 - troubleshooting, 99
 - when closing lid, 50
 - when used, 48, 50
- startup, troubleshooting, 98
- static electricity
 - precautions, 74
- status lights
 - battery charge, 19, 51
 - Caps Lock, 20
 - , 20
 - , 20
 - , 20
 - keyboard, 20
 - location, 19
 - Num Lock, 20
 - power mode, 19, 20
 - Pad Lock, 20
- Support Ticket, 101
- system-off switch
 - using, 29
- T**
- technical support, 110
- technology codes, 118
- testing hardware, 100
- timeouts
 - display, 45
 - notebook, 48, 49, 97
- touch pad
 - configuring, 31
 - troubleshooting, 87
 - using, 30, 31
- troubleshooting
 - audio, 81
 - battery, 96
 - CD-ROM drive, 82

- display, 84
- DVD drive, 82
- floppy disk drive, 85
- hard disk drive, 86
- HP Instant Support, 80
- information sources, 80
- keyboard, 87
- LAN, 88
- memory, 89
- modem, 90, 91
- mouse, 87
- One-Touch buttons, 92
- parallel port, 93
- PC card, 94
- performance, 95
- power, 96
- printing, 97
- resume, 99
- standby, 99
- startup, 98
- touch pad, 87
- USB port, 93

U

- USB**
 - connecting device, 69
 - troubleshooting port, 93
- Utility partition
 - creating, 75, 76

V

- virus protection
 - Norton AntiVirus, 41
- volume
 - adjusting, 36

W

- web sites
 - HP Customer Care, 15, 94
 - HP Notebooks, 14
- Windows
 - documentation, 14
 - password, 40
 - reinstalling, 104
 - setting up, 25
 - updating drivers, 107
- Windows key
 - key combinations, 34
- work environment, 42
- working in comfort, 42

