

HP Advanced Docking Station Reference Guide

© Copyright 2008 Hewlett-Packard
Development Company, L.P.

Microsoft is a registered trademark of
Microsoft Corporation.

The information contained herein is subject
to change without notice. The only
warranties for HP products and services are
set forth in the express warranty statements
accompanying such products and services.
Nothing herein should be construed as
constituting an additional warranty. HP shall
not be liable for technical or editorial errors
or omissions contained herein.

First Edition: May 2008

Document Part Number: 463096-001

Table of contents

1 Components

Top components	1
Left-side components	2
Right-side components	2
Rear components	3
Getting more information	4

2 Docking and undocking

Connecting to AC power	5
Docking the computer	6
Undocking the computer	8

3 Using the advanced docking station

Turning the computer on and off	9
Using the SATA swappable bay	9
Removing and inserting drives	10
Inserting a drive	10
Removing a drive	11
Backing up your information	11
Inserting and removing optical discs	12
Inserting an optical disc	12
Removing an optical disc	12
Manually releasing the disc tray	12
Using ExpressCards	13
Inserting an ExpressCard	13
Removing an ExpressCard	14
Installing the HP/Kensington Cable Lock	15

Appendix A Troubleshooting

Solving common problems	19
Docking and undocking problems and solutions	19
External device problems and solutions	20
Optical drive problems and solutions	20
SATA swappable bay problems and solutions	21

Index	22
-------------	----

1 Components

Top components

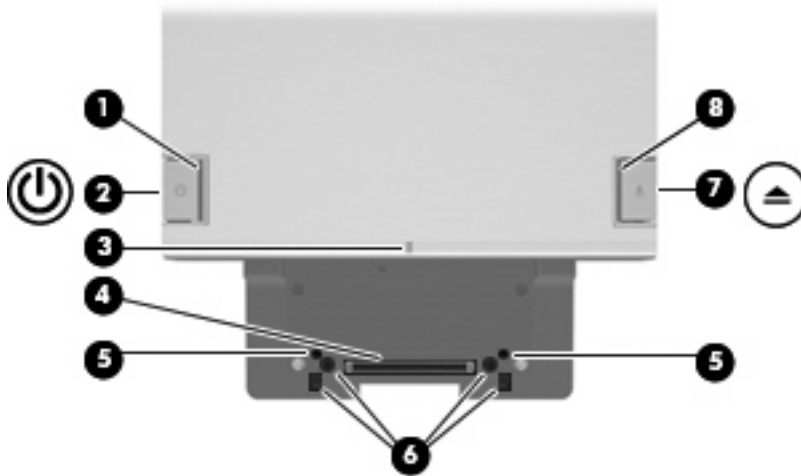

Component	Description
(1) Power light	Indicates the state of the computer and is turned on when the computer is turned on.
(2) Power button	Turns on power to the computer.
(3) Visual alignment indicator	Helps you correctly align the computer when connecting it to the docking station.
(4) Docking connector	Connects the computer to the docking station.
(5) Docking posts (2)	Align and secure the computer for proper connection to the docking station.
(6) Computer eject mechanisms (4)	Disconnect the computer from the docking station when you press the eject button.
(7) Computer eject button	Ejects the computer from the docking station.
(8) Docking light	On: The computer is properly aligned.

Left-side components

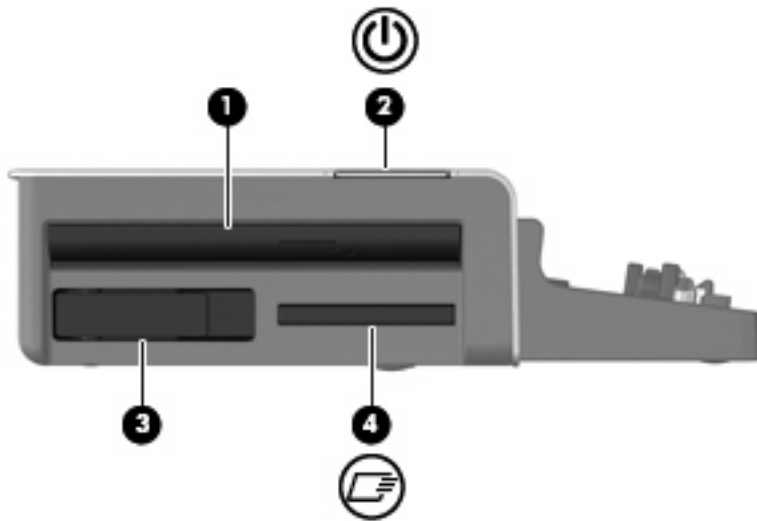

Components	Description
(1) SATA swappable bay	Supports 12.7-mm drives such as hard drives and optical drives. NOTE: The SATA swappable bay is only compatible with select computer models.
(2) Power button and power light	Turns on power to the computer. The light is on when the computer is turned on.
(3) SATA swappable bay release lever	Releases the drive from the SATA swappable bay.
(4) ExpressCard slot	Allows you to connect ExpressCard devices to the docking station.

Right-side components

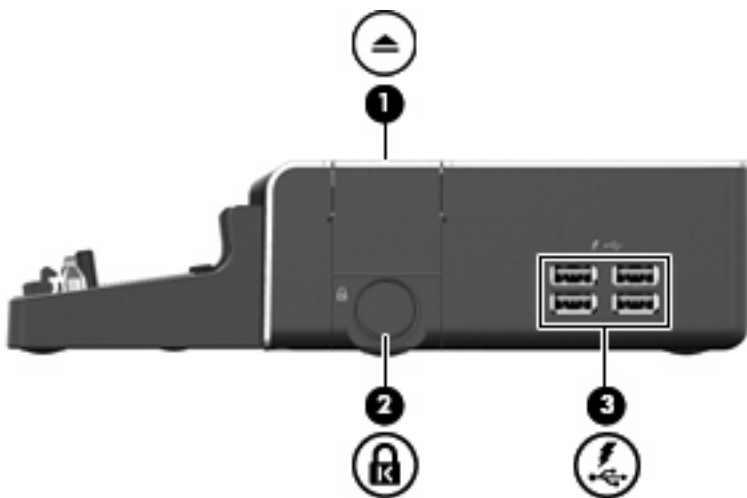

Components	Description
(1) Computer eject button and docking light	Ejects the computer from the docking station. The docking light turns on when the computer is properly aligned.
(2) Integrated cable lock slot	Supports the HP/Kensington Cable Lock, which secures the docking station, connected computer, and SATA swappable bay drive. NOTE: A security cable is designed to act as a deterrent, but it may not prevent the computer or the docking station from being mishandled or stolen.
(3) USB ports (4)	Allow you to connect and charge USB devices even when the computer is off or undocked. NOTE: If an optional USB hard drive is connected to this USB port, the hard drive will not turn off. This USB port does not turn off when the computer is off or undocked.

Rear components

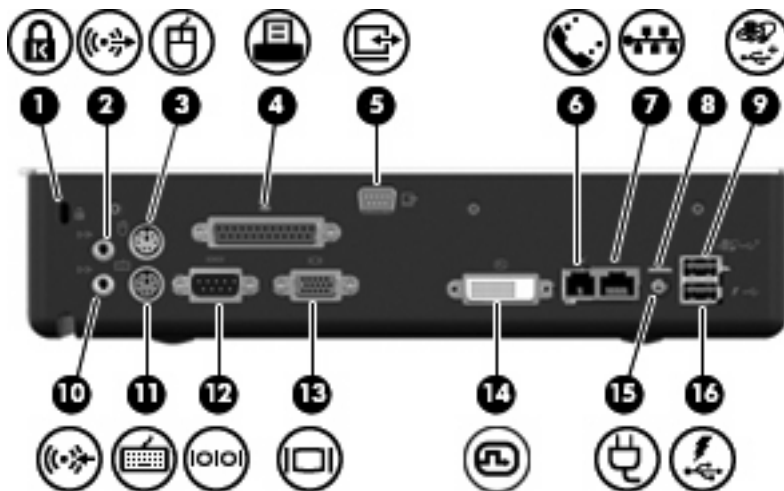

Components	Components
(1) Security cable slot	Connects an optional security cable lock. NOTE: The security cable is designed to act as a deterrent, but it may not prevent the computer and docking station from being mishandled or stolen.
(2) Audio-out (headphone) jack	Connects an audio output device such as headphones or speakers.
(3) Mouse connector	Connects a PS/2 mouse.
(4) Parallel port	Connects a parallel device such as a printer.
(5) Monitor stand port	Connects an optional HP Monitor Stand to the docking station.
(6) RJ-11 (modem) jack	Connects a telephone cable.
(7) RJ-45 (network) jack	Connects a network cable.
(8) Power light	On: The docking station is connected to AC power.

Components		Components
(9)	Powered USB 2.0 port	Allows you to connect an HP USB MultiBay II optical drive or hard drive. Other USB hard drives can be connected to this port even when the computer is off or undocked. NOTE: This USB port turns off when the computer is off or undocked.
(10)	Audio-in (microphone) jack	Connects an optional computer headset microphone, stereo array microphone, or monaural microphone.
(11)	Keyboard connector	Connects a PS/2 keyboard.
(12)	Serial port	Connects a serial device such as a mouse.
(13)	External monitor port	Connects an external VGA monitor.
(14)	Digital video (DVI) port	Connects a DVI device such as a flat panel monitor.
(15)	Power connector	Connects the docking station to the AC adapter.
(16)	USB 2.0 port	Allows you to connect and charge USB devices even when the computer is off or undocked. NOTE: If an optional USB hard drive is connected to this USB port, the hard drive will not turn off. This USB port does not turn off when the computer is off or undocked.

Getting more information

⚠ WARNING! To reduce the risk of serious injury, read the *Safety & Comfort Guide*. It describes proper workstation setup, and proper posture, health, and work habits for notebook users. The *Safety & Comfort Guide* also provides important electrical and mechanical safety information. To access this document, select **Start > Help and Support**, or refer to the *User Guides* disc included with some models. The *Safety & Comfort Guide* is also available on the Web at <http://www.hp.com/ergo>.

- The user guides, included with your computer, contain comprehensive information about your computer, as well as governmental agency and safety information about the use of your computer.
- The *Accessory Documentation* CD, included with the docking station, contains governmental agency and safety information about the use of this device.
- See HP Web site at <http://www.hp.com> to find product news and software updates.

2 Docking and undocking

Connecting to AC power

Connect the advanced docking station to AC power at all times. The docking station requires AC power for full functionality of all ports and connectors.

⚠ **WARNING!** To reduce the risk of electric shock or damage to your equipment:

Plug the power cord into an AC outlet that is easily accessible at all times.

Disconnect the power from the product by unplugging the power cord from the AC outlet.

If provided with a 3-pin attachment plug on your power cord, plug the cord into a grounded (earthed) 3-pin outlet. Do not disable the power cord grounding pin; for example, do not attach a 2-pin adapter. The grounding pin is an important safety feature.

Do not place anything on power cords or cables. Arrange them so that no one can accidentally step on or trip over them.

Do not pull on a cord or cable. When unplugging a cord from the AC outlet, grasp the cord by the plug.

WARNING! To reduce the risk of electric shock, fire, or damage to the equipment, do not attempt to operate the computer and docking station with a voltage converter kit sold for appliances. Use only the power cord included with the docking station.

1. Insert the AC adapter **(1)** into the power connector on the docking station.
2. Insert one end of the power cord **(2)** into the AC adapter.

3. Insert the other end of the power cord (3) into an AC outlet.



 **NOTE:** The light above the power connector turns on when the docking station is connected to AC power.

Docking the computer

1. Close the computer. If you close the computer when the power is on, the computer may enter the Sleep state or Standby. To resume operation after docking, open the computer, and then press the power button.
2. Pivot the front of the computer downward.

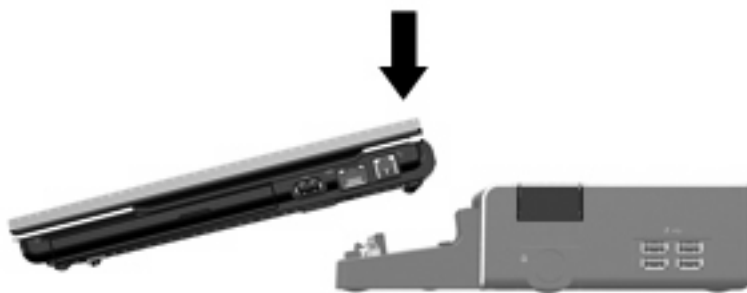

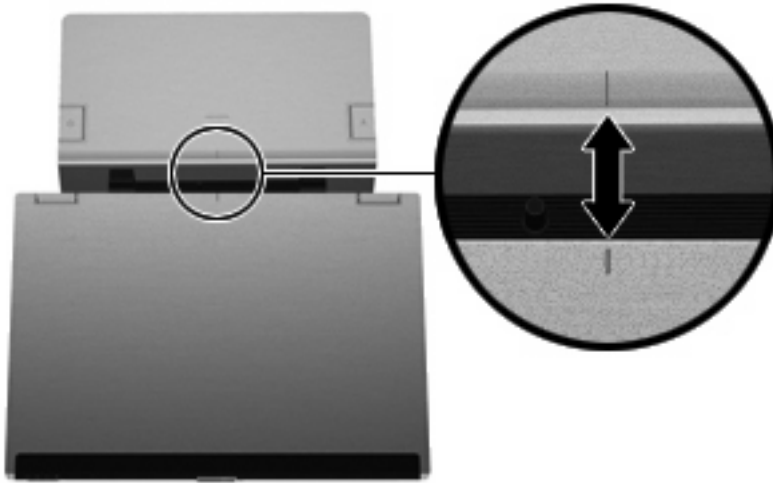

3. Line up the visual alignment indicator on the computer with the indicator on the docking station.

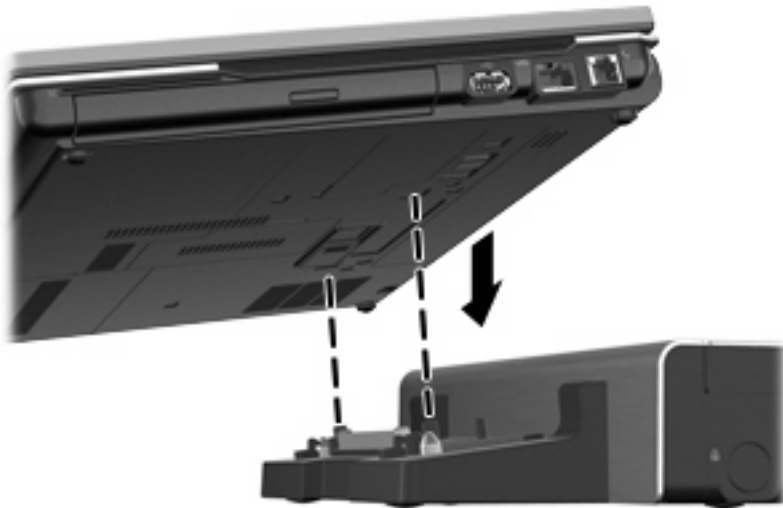

4. Align the posts on the docking station with the receptors on the bottom of the computer, and then gently press the computer down onto the docking station until you hear a click. When the computer is properly aligned, the docking station docking light turns on.

 **NOTE:** Be sure that the computer is properly aligned and seated, and fully docked. For help with most common docking problems, refer to Appendix A, “Troubleshooting.”



 **NOTE:** The docking light will not turn on when you dock the computer unless the AC adapter is connected to the docking station.

Undocking the computer

1. Close the computer. If you close the computer when the power is on, the computer may enter the Sleep state or Standby. To resume operation after undocking, open the computer, and then press the power button.



2. Press the eject button (1). The computer disconnects from the docking station.
3. Lift up the computer (2).

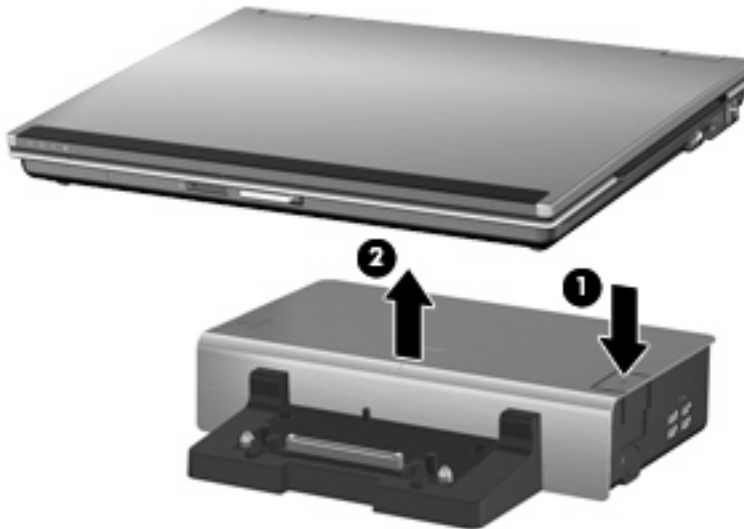

3 Using the advanced docking station

Turning the computer on and off

When you connect a computer to the advanced docking station, you can turn the computer on and off using either the computer power button or the docking station power button **(1)**. When you turn on the system, the power button light turns on **(2)**. When you properly align the computer to the docking station, the docking light **(3)** turns on.

 **NOTE:** The docking light will not turn on when you dock the computer unless the AC adapter is connected to the docking station. For help with most common docking problems, refer to Appendix A, “Troubleshooting.”



Using the SATA swappable bay

 **NOTE:** The SATA swappable bay is only compatible with select computer models.

You can use the following optional 12.7-mm drives in the docking station SATA swappable bay:

- Optical drives, such as a DVD+RW/R and CD-RW Combo Drive or a DVD/CD-RW Combo Drive
- Hard drive adapters

Removing and inserting drives

Inserting a drive

 **NOTE:** If you are using the HP/Kensington Cable Lock, you must unlock the device to insert a drive into the SATA swappable bay.

1. Turn off the computer.
2. If a protective insert is installed, pull the lever (1) to release the protective insert, and then remove the protective insert (2) from the bay.

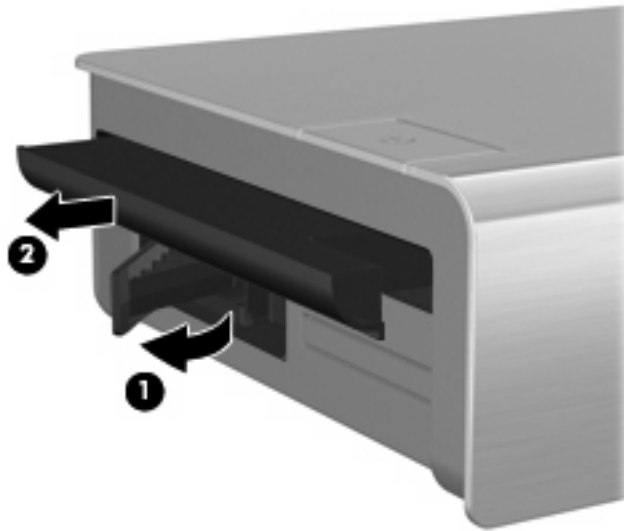

3. Slide the drive into the bay until it clicks into place.



4. Turn on the computer.

 **NOTE:** The first time you insert a drive into the SATA swappable bay, the Add New Hardware wizard may open. Follow the instructions, if necessary.

Removing a drive

△ **CAUTION:** To avoid playback distortion or damage to an optical disc, stop the disc and exit multimedia software before inserting or removing an optical drive.

📝 **NOTE:** If you use the HP/Kensington Cable Lock, you must unlock the device before you can remove a drive from the SATA swappable bay. For more information, refer to “Installing the HP/Kensington Cable Lock” later in this chapter.

1. Close all programs and complete all activities that are supported by the drive.
2. Stop the drive:
 - a. Double-click **Safely Remove Hardware** icon in the notification area, at the far right of the taskbar.

📝 **NOTE:** To display the Safely Remove Hardware icon on the taskbar, click the **Show Hidden Icons** icon (< or <<) in the notification area.
 - b. Click the name of the drive in the list.

📝 **NOTE:** If the drive is not listed, you do not have to stop the drive before you remove it.
 - c. Click **Stop**, and then click **OK**.
3. Pull the lever to release the drive (1). The drive is ejected.
4. Slide the drive out of the bay (2). After the drive is removed, the lever will return to the closed position.

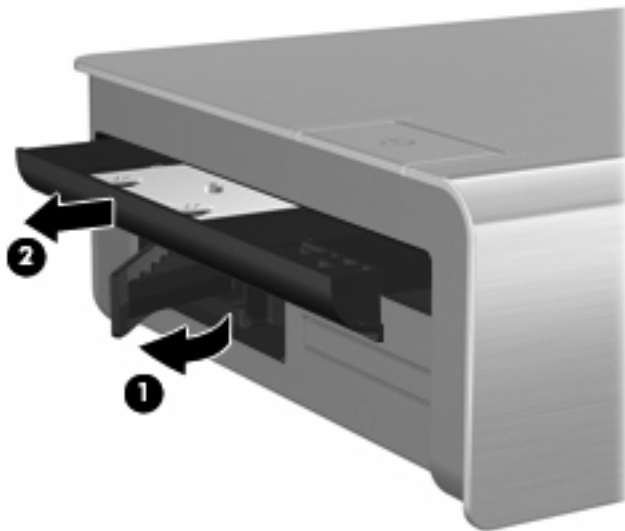

Backing up your information

Select computer models support Intel Rapid Recovery Technology (IRRT) on the docking station when you have a hard drive installed in the SATA swappable bay. IRRT allows you to perform incremental backups of the information stored on your computer to the docking station hard drive.

📝 **NOTE:** IRRT is enabled on select computer models. Refer to the user guides included with your computer for additional information.

Inserting and removing optical discs

Inserting an optical disc

1. Press the release button on the drive to open the disc tray, and then pull the tray out until it is fully extended.

 **NOTE:** If the tray is not fully accessible, tilt the disc carefully to position it over the spindle.

2. Position a disc over the tray, label side up. Handle the disc by the edges, not the flat surfaces.
3. Gently press the center of the disc onto the tray spindle until the disc snaps into place.
4. Close the disc tray.

If you have not yet configured AutoPlay, an AutoPlay dialog box opens. It prompts you to select how you want to use the media content.

Removing an optical disc

You can release the disc tray from a drive using either of the following procedures:

- Press the release button on the drive bezel.
- Use computer software to release the disc tray.

If neither of these methods is successful, you can manually release the disc tray. For more information, refer to the next section, “Manually releasing the disc tray.”

Manually releasing the disc tray

 **CAUTION:** To reduce the risk of damage to the tray or the computer, before beginning this procedure, turn off the computer, the advanced docking station, and all connected devices.

Certain programs or operating system software may disable the disc tray release button to prevent accidental damage to a disc.

To remove a disc from an optical drive without using the release button, follow these steps:

1. Insert the end of a paper clip into the release access in the front of the drive.

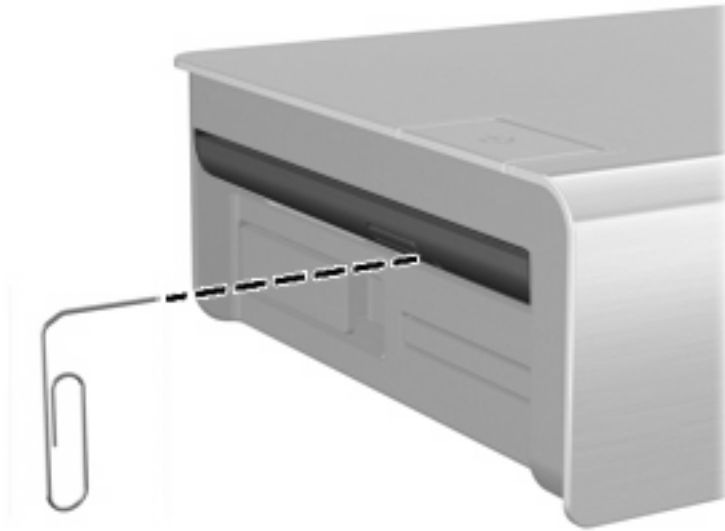

2. Press in gently on the paper clip until the disc tray is released, and then pull the tray out until it is fully extended.
3. Remove the disc from the tray by gently pressing down on the spindle while lifting the outer edges of the disc. Handle the disc by the edges, not the flat surfaces.

 **NOTE:** If the disc tray is not fully extended, tilt the disc as you remove it.

4. Close the disc tray and place the disc in a protective case.

Using ExpressCards

An ExpressCard is a high-performance PC Card that is inserted into the ExpressCard slot. Like standard PC Cards, ExpressCards are designed to conform to the standard specifications of the Personal Computer Memory Card International Association (PCMCIA). To support a broad range of applications, ExpressCards come in 2 sizes: ExpressCard/34 and ExpressCard/54. The ExpressCard slot on your docking station supports either size.

Inserting an ExpressCard

 **CAUTION:** To prevent damage to ExpressCard connectors, use minimal force when inserting an ExpressCard into the slot.

To insert an ExpressCard:

1. If a protective insert is installed, press firmly on the right side of the protective insert, and then release quickly to eject it.
2. Hold the ExpressCard label-side up with the connectors facing the docking station.

3. Gently slide the card into the slot until the card is seated.

You will hear a sound when the device has been detected, and a menu of options may be displayed.

 **NOTE:** The first time you insert an ExpressCard, the “Installing device driver software” message is displayed in the notification area, at the far right of the taskbar.

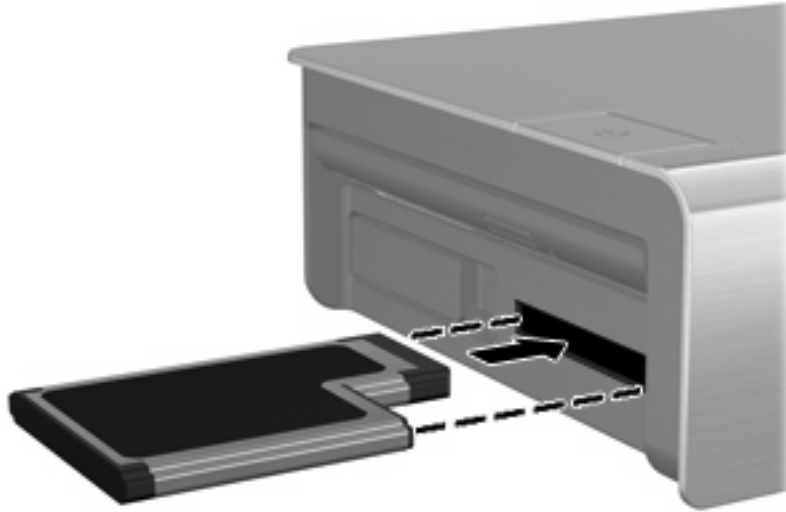

Removing an ExpressCard

 **CAUTION:** To prevent loss of data or an unresponsive system, stop an ExpressCard before removing it.

To remove an ExpressCard:

1. Close all programs and complete all activities that are supported by the ExpressCard.
2. Stop the ExpressCard:
 - a. Double-click the **Safely Remove Hardware** icon in the notification area, at the far right of the taskbar.
 **NOTE:** To display the Safely Remove Hardware icon, click the Show Hidden Icons icon (< or <<) in the notification area.
 - b. Click the name of the ExpressCard in the list.
 - c. Click **Stop**, and then click **OK**.
3. Release and remove the ExpressCard:
 - a. Gently press in on the ExpressCard **(1)** to unlock it.
 - b. Pull the ExpressCard out of the slot **(2)**.

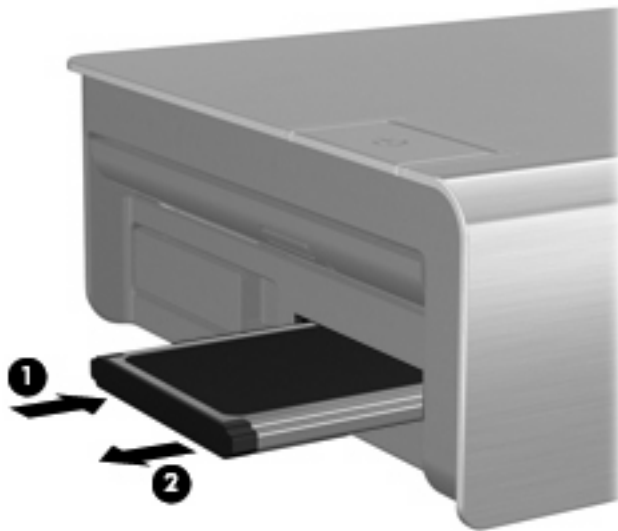

Installing the HP/Kensington Cable Lock

 **NOTE:** A security cable is designed to act as a deterrent, but it may not prevent the computer or the docking station from being mishandled or stolen.

The HP/Kensington Cable Lock (purchased separately) allows you to secure the docking station, a docked computer, and a SATA swappable bay drive installed in the docking station. Install the cable lock into the integrated cable lock slot on the right side of the docking station, as shown in the following procedure.



To install the cable lock:

1. Loop the cable around a stationary object.
2. Turn the docking station upside down, and then remove the screws from the cable lock bezel (1).
3. Remove the cable lock bezel from the docking station (2), and then remove the bezel blank from the cable lock bezel (3).

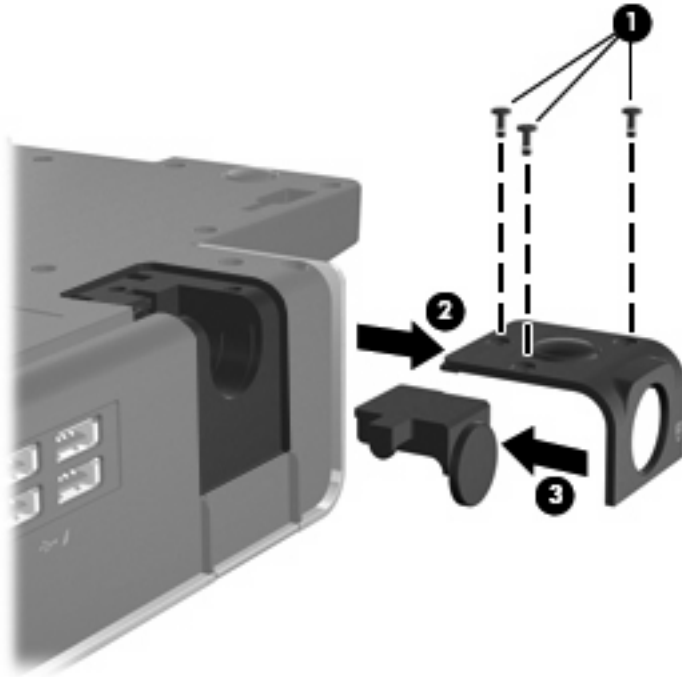

4. With the lock and key in the unlocked position and with the T-bar on the back of the lock in the vertical position, insert the lock into the center groove in the cable lock slot in the docking station (1).

5. Insert the cable into the recessed cable channel in the base of the docking station (2).

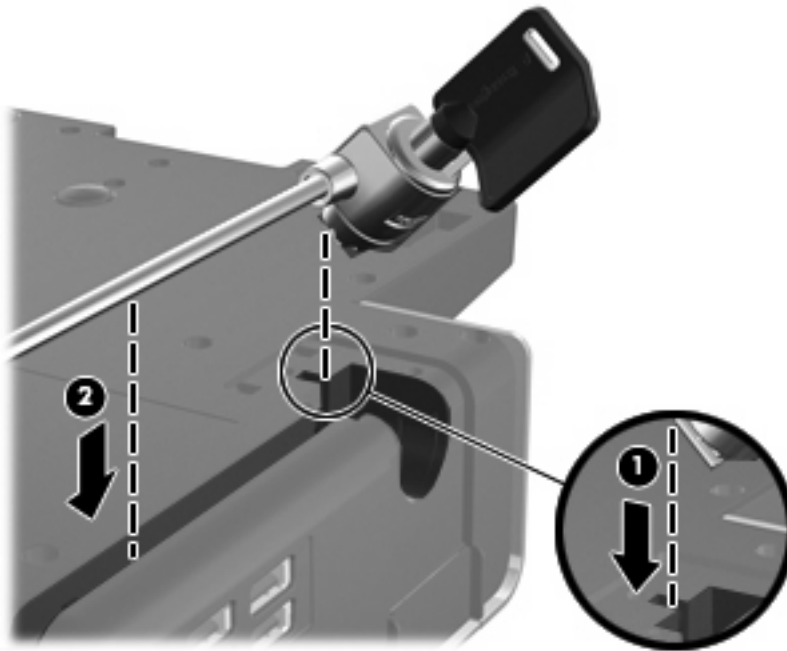

6. Turn the key counterclockwise to lock (1).
7. Remove the key from the lock (2).
8. Reinsert the cable lock bezel onto the docking station (3).
9. Replace the screws to secure the bezel (4).

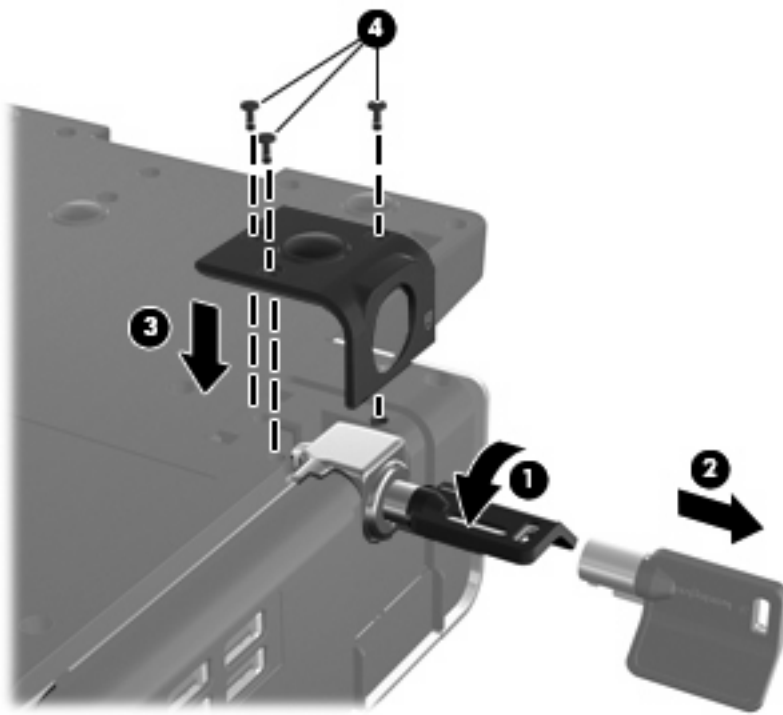

The following illustration shows a docking station with the HP/Kensington Cable Lock installed.

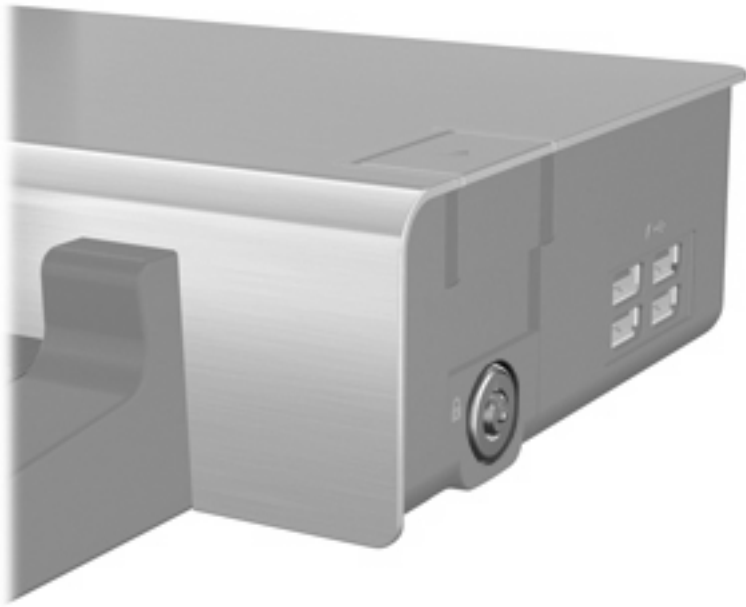

A Troubleshooting

This section provides three resources for resolving issues you may encounter when using your docking station. Try these resources in the following order:

- Many problems may be easy to resolve as indicated in the next section, “Solving common problems.”
- To access Help and Support, select **Start > Help and Support**. In addition to providing information about your operating system, Help and Support provides a searchable database of help topics, updated regularly by HP and Microsoft. Type in the name of your accessory—for example, `docking station`—to search for relevant topics in the HP Knowledge Base and Microsoft® Knowledge Base.
- If you need additional assistance, see the HP Web site at <http://www.hp.com>. Then select your country or region.

Solving common problems

Docking and undocking problems and solutions

Problem	Possible cause	Solution
The computer is not properly connected to the docking station.	The computer may be properly aligned, but is not fully seated or docked in the docking station.	Lift the computer away from the docking station. Then realign the computer visual alignment indicator with the indicator on the docking station, and reconnect the computer. Be sure that the computer is properly aligned and seated, and fully docked by gently pressing down on the computer until you hear a click. If accessories are attached, they should now work properly.
The computer is turned on and properly docked, but the power light and docking light are not on.	The power cord is not plugged into either the docking station or the AC outlet.	Properly plug in power cord.
Some of the ports or connectors do not work, even though the docking light is on.	The computer may be properly aligned, but is not fully seated or docked in the docking station.	Lift the computer away from the docking station. Then realign the computer visual alignment indicator with the indicator on the docking station, and then reconnect the computer. Be sure that the computer is properly aligned and seated, and fully docked by gently pressing down on the computer until you hear a click. If accessories are attached, they should now work properly.

The computer will not disconnect from the docking station.	The connectors may be jammed.	Press the eject button all the way in. If the computer does not disconnect, repeat this procedure to disconnect the computer. CAUTION: Applying excessive force may damage connector pins.
	The HP/Kensington Cable Lock is in the locked position.	Unlock the lock and then disconnect the computer.

External device problems and solutions

Problem	Possible cause	Solution
A new device is not recognized as part of the system	The computer may be properly aligned, but is not fully seated or docked in the docking station.	Lift the computer away from the docking station. Then realign the computer visual alignment indicator with the indicator on the docking station, and reconnect the computer. Be sure that the computer is properly aligned and seated, and fully docked by gently pressing down on the computer until you hear a click. If accessories are attached, they should now be recognized by the system.
	The device cable or power cord is loose.	<ul style="list-style-type: none"> Be sure that all cables are securely connected to the device and the docking station. Be sure that all power cords are securely connected to the device or docking station and to an AC outlet.
	The device was connected while the system was on.	Turn off the computer, turn on the device (if applicable), and then restart the computer.
	Cabling is incorrect.	Be sure that the device cable is in the correct connector on the docking station.
	You may need to install device drivers on the computer.	Install drivers according to the device manufacturer's instructions.

Optical drive problems and solutions

Problem	Possible cause	Solution
The system cannot read the optical disc.	The disc is not properly seated in the disc tray.	Remove the disc, reseal it in the disc tray, and then close the disc tray.
	The disc is upside down.	Remove the disc, turn it over, and then close the disc tray.
	The disc may be dirty or scratched.	Replace the disc.
The system cannot eject the disc tray.	The disc is not properly seated in the disc tray.	Turn off the computer, and then manually eject the disc tray as shown in the section "Inserting and removing optical discs" in

Chapter 3, "Using the advanced docking station."

There is no power to the docking station.

- Turn on power to the system, and then eject the disc.
 - Manually eject the disc as shown in the section "Manually releasing the disc tray" in Chapter 3, "Using the advanced docking station."
-

SATA swappable bay problems and solutions

Problem	Possible cause	Solution
The SATA swappable bay drive is not recognized.	The drive is not properly inserted in the bay.	Remove the drive, and then reinsert it as shown in the section "Removing and inserting drives" in Chapter 3, "Using the advanced docking station."
	The drive was inserted while the power was on.	Restart the computer while the drive is in the bay.

Index

- A**
 - AC adapter, connecting 5
 - audio-in (microphone) jack, identifying 4
 - audio-out (headphone) jack, identifying 3
- B**
 - buttons
 - computer eject 1, 3
 - power 1, 2
- C**
 - cable lock slot, identifying 3
 - computer
 - docking 6
 - turning on and off 9
 - undocking 8
 - computer eject button, identifying 1, 3
 - computer eject mechanisms, identifying 1
 - connecting the AC adapter 5
 - connectors
 - docking 1
 - keyboard 4
 - mouse 3
 - power 4
- D**
 - digital video (DVI) port, identifying 4
 - docking connector, identifying 1
 - docking light, identifying 1, 3
 - docking posts, identifying 1
 - docking the computer 6
 - docking, troubleshooting 19
 - drives
 - inserting 10
 - removing 11
- E**
 - ExpressCard
 - inserting 13
 - removing 14
 - ExpressCard slot, identifying 2
 - external device, troubleshooting 20
 - external monitor port, identifying 4
- H**
 - headphone jack, identifying 3
 - HP/Kensington cable lock, installing 15
- I**
 - integrated cable lock slot, identifying 3
 - Intel Rapid Recovery Technology 11
- J**
 - jacks
 - audio-in 4
 - audio-out (headphone) 3
 - RJ-11 (modem) 3
 - RJ-45 (network) 3
- K**
 - keyboard connector, identifying 4
- L**
 - lights
 - docking 1, 3
 - power 1, 2, 3
- M**
 - microphone jack, identifying 4
 - modem jack, identifying 3
 - monitor stand port, identifying 3
- N**
 - mouse connector, identifying 3
 - network jack, identifying 3
- O**
 - optical disc
 - inserting 12
 - removing 12
 - removing manually 12
 - optical drive, troubleshooting 20
- P**
 - parallel port, identifying 3
 - ports
 - digital video (DVI) 4
 - external monitor 4
 - monitor stand 3
 - parallel 3
 - serial 4
 - USB 3, 4
 - power button, identifying 1, 2
 - power connector, identifying 4
 - power light, identifying 1, 2, 3
- R**
 - RJ-11 (modem) jack, identifying 3
 - RJ-45 (network) jack, identifying 3
- S**
 - Safety & Comfort Guide 4
 - SATA swappable bay
 - identifying 2
 - release lever 2
 - troubleshooting 21
 - using 9
 - security cable slot, identifying 3
 - serial port, identifying 4

slots

- cable lock 3
- ExpressCard 2
- security cable 3

T

troubleshooting

- docking problems 19
 - external device problems 20
 - optical drive problems 20
 - SATA swappable bay 21
 - undocking 19
- turning off the computer 9
- turning on the computer 9

U

- undocking the computer 8
- undocking, troubleshooting 19
- USB ports, identifying 3, 4

V

- visual alignment indicator,
identifying 1

