



HP 15 Laptop PC

Maintenance and Service Guide

© Copyright 2018 HP Development Company, L.P.

AMD and AMD Radeon are trademarks of Advanced Micro Devices, Inc. Bluetooth is a trademark owned by its proprietor and used by HP Inc. under license. Intel and Core are trademarks of Intel Corporation in the U.S. and other countries. Microsoft and Windows are trademarks of the Microsoft group of companies.

The information contained herein is subject to change without notice. The only warranties for HP products and services are set forth in the express warranty statements accompanying such products and services. Nothing herein should be construed as constituting an additional warranty. HP shall not be liable for technical or editorial errors or omissions contained herein.

Second Edition: September 2018

First Edition: April 2018

Document Part Number: L19674-002

Product notice

This user guide describes features that are common to most models. Some features may not be available on your computer.

Not all features are available in all editions or versions of Windows. Systems may require upgraded and/or separately purchased hardware, drivers, software or BIOS update to take full advantage of Windows functionality. Windows 10 is automatically updated, which is always enabled. ISP fees may apply and additional requirements may apply over time for updates. See <http://www.microsoft.com>.

To access the latest user guides, go to <http://www.hp.com/support>, and follow the instructions to find your product. Then select **User Guides**.

Software terms

By installing, copying, downloading, or otherwise using any software product preinstalled on this computer, you agree to be bound by the terms of the HP End User License Agreement (EULA). If you do not accept these license terms, your sole remedy is to return the entire unused product (hardware and software) within 14 days for a full refund subject to the refund policy of your seller.

For any further information or to request a full refund of the price of the computer, please contact your seller.

Important Notice about Customer Self-Repair Parts

 **CAUTION:** Your computer includes Customer Self-Repair parts and parts that should only be accessed by an authorized service provider. See Chapter 5, "Removal and replacement procedures for Customer Self-Repair parts," for details. Accessing parts described in Chapter 6, "Removal and replacement procedures for Authorized Service Provider only parts," can damage the computer or void your warranty.

Safety warning notice

 **WARNING!** To reduce the possibility of heat-related injuries or of overheating the device, do not place the device directly on your lap or obstruct the device air vents. Use the device only on a hard, flat surface. Do not allow another hard surface, such as an adjoining optional printer, or a soft surface, such as pillows or rugs or clothing, to block airflow. Also, do not allow the AC adapter to contact the skin or a soft surface, such as pillows or rugs or clothing, during operation. The device and the AC adapter comply with the user-accessible surface temperature limits defined by the International Standard for Safety of Information Technology Equipment (IEC 60950-1).

Table of contents

1 Product description	1
2 Getting to know your computer	6
Right side	6
Left side	7
Display	8
Keyboard area	9
TouchPad	9
Lights	10
Button and speakers	11
Special keys	12
Action keys	13
Bottom	14
Labels	15
3 Illustrated parts catalog	16
Computer major components	16
Cables	21
Display assembly subcomponents	22
Miscellaneous parts	25
Mass storage devices	26
4 Removal and replacement procedures preliminary requirements	28
Tools required	28
Service considerations	28
Plastic parts	28
Cables and connectors	29
Drive handling	29
Grounding guidelines	30
Electrostatic discharge damage	30
Packaging and transporting guidelines	31
Workstation guidelines	31
Equipment guidelines	32
5 Removal and replacement procedures for Customer Self-Repair parts	33
Component replacement procedures	33

Preparation for disassembly	33
Optical drive	34

6 Removal and replacement procedures for Authorized Service Provider parts 37

Component replacement procedures	37
Bottom cover	38
Battery	41
Memory	43
Hard drive	45
Solid-state drive	47
Solid-state drive bracket and connector board	48
Optane memory module	50
WLAN module	51
Hard drive connector board	52
USB/card reader board	53
TouchPad button board	54
TouchPad module	55
Fan	57
Heat sink assembly	58
Display assembly	62
System board	72
Speakers	75
Power connector cable (DC-in)	76
Top cover with keyboard	77

7 Using Setup Utility (BIOS) 78

Starting Setup Utility (BIOS)	78
Updating Setup Utility (BIOS)	78
Determining the BIOS version	78
Downloading a BIOS update	79

8 Using HP PC Hardware Diagnostics 80

Using HP PC Hardware Diagnostics Windows (select products only)	80
Downloading HP PC Hardware Diagnostics Windows	80
Downloading the latest HP PC Hardware Diagnostics Windows version	81
Downloading HP Hardware Diagnostics Windows by product name or number (select products only)	81
Installing HP PC Hardware Diagnostics Windows	81
Using HP PC Hardware Diagnostics UEFI	81
Starting HP PC Hardware Diagnostics UEFI	82

Downloading HP PC Hardware Diagnostics UEFI to a USB flash drive	82
Downloading the latest HP PC Hardware Diagnostics UEFI version	82
Downloading HP PC Hardware Diagnostics UEFI by product name or number (select products only)	82
Using Remote HP PC Hardware Diagnostics UEFI settings (select products only)	83
Downloading Remote HP PC Hardware Diagnostics UEFI	83
Downloading the latest Remote HP PC Hardware Diagnostics UEFI version	83
Downloading Remote HP PC Hardware Diagnostics UEFI by product name or number	83
Customizing Remote HP PC Hardware Diagnostics UEFI settings	83
9 Backing up, restoring, and recovering	85
Backing up information and creating recovery media	85
Using Windows tools	85
Using the HP Cloud Recovery Download Tool to create recovery media (select products only)	85
Restoring and recovery	86
Restoring, resetting, and refreshing using Windows tools	86
Recovering using HP Recovery media	86
Changing the computer boot order	86
10 Specifications	87
Computer specifications	87
39.6-cm (15.6-in) display specifications	88
M.2 SATA solid-state drive specifications	88
M.2 PCIe solid-state drive specifications	89
Hard drive specifications	90
11 Power cord set requirements	91
Requirements for all countries	91
Requirements for specific countries and regions	91
12 Recycling	93
Index	94

1 Product description

Category	Description
Product Name	HP 15 Laptop PC Model numbers: 15-da1000 ~ 15-da1999 15-da0000 ~ 15-da0999 15g-dr1000 ~ 15g-dr1999 15g-dr0000 ~ 15g-dr0999 15q-ds1000 ~ 15q-ds1999 15q-ds0000 ~ 15q-ds0999 15t-da000, 15t-da100
Processor	8th-generation Intel® Core™ processors: i7-8565U 1.80-GHz (SC turbo up to 4.60-GHz) quad-core processor (8.0-MB L3 cache, 2400-MHz FSB, 15 W) i7-8550U 1.80-GHz (SC turbo up to 4.00-GHz) quad core processor (8.0-MB L3 cache, 2400-MHz FSB, 15 W) i5-8265U 1.60-GHz (SC turbo up to 4.10-GHz) quad-core processor (6.0-MB L3 cache, 2400-MHz FSB, 15 W) i5-8250U 1.60-GHz (SC turbo up to 3.40-GHz) quad core processor (6.0-MB L3 cache, 2400-MHz FSB, 15 W) i3-8145U 2.10-GHz (SC turbo up to 3.90-GHz) quad-core processor (4.0-MB L3 cache, 2400-MHz FSB, 15 W) i3-8130U 2.20-GHz (SC turbo up to 3.40-GHz) dual core processor (4.0-MB L3 cache, 2400-MHz FSB, 15 W) 7th-generation Intel Core processors: i7-7500U 2.70-GHz (SC turbo up to 3.50-GHz) dual core processor (4.0-MB L3 cache, 2133-MHz FSB, 15 W) i3-7020U 2.30-GHz dual core processor (3.0-MB L3 cache, 2133-MHz FSB, 15 W) Intel Pentium® and Celeron® processors: Intel Pentium Silver N5000 1.10-GHz (SC turbo up to 2.70-GHz) quad core processor (4.0-MB L3 cache, 2400-MHz FSB, 6 W) Intel Celeron N4000 1.10-GHz (SC turbo up to 2.60-GHz) dual core processor (4.0-MB L3 cache, 2400-MHz FSB, 6 W)
Graphics	Supports HD decode, DX12, HDMI Internal graphics: Intel UHD Graphics 620 (8th generation Intel processors) Intel UHD Graphics 605 (Intel Pentium processors) Intel UHD Graphics 600 (Intel Celeron processors) Intel HD Graphics 620 (7th generation Intel processors) External graphics: (Intel Core processors) GeForce MX130 with up to 4 GB of dedicated video memory

Category	Description
	GeForce MX130 with up to 2 GB of dedicated video memory
	GeForce MX110 with up to 2 GB of dedicated video memory
Panel	39.6-cm (15.6-in), WLED, eDP, slim-flat (3.2 mm), 16:10 ultra wide aspect ratio:
	High definition (HD)(1366×768), BrightView, SVA, 220 nits
	HD (1366×768), anti glare, SVA, 220 nits
	HD (1366×768), BrightView, SVA, 200 nits, Touch on Panel (TOP)
	Full high-definition (FHD) (1920×1080), anti glare, SVA, 220 nits
	FHD (1920×1080), BrightView, UWVA, 220 nits, narrow bezel
	Touch solution with bezel, multi-touch enabled
Memory	Two memory module slots (Intel Core processors):
	Memory is non-customer accessible/non-upgradeable
	DDR4-2666 bridge to DDR4-2400 dual channel support (i7-8565U, i5-8265U, i3-8145U processors)
	DDR4-2400 dual channel support (i7-8500U, i5-8250U i3-8130U processors)
	DDR4-2133 dual channel support (i7-7500U, i3-7020U processors)
	Supports up to 16 GB of system RAM in the following configurations:
	<ul style="list-style-type: none"> • 16384 MB (8192 MB×2) • 12288 MB (8192 MB×1 + 4096 MB×1) • 8192 MB (8192 MB×1 + 4096×2) • 4096 MB (4096 MB×1 or 2048×2)
	One memory module slot (Intel Pentium and Celeron processors):
	Memory is non-customer accessible/non-upgradeable
	DDR4-2400 single channel support
	Supports up to 8 GB of system RAM in the following configurations:
	<ul style="list-style-type: none"> • 8192 MB (8192 MB×1) • 4096 MB (4096 MB×1)
Primary storage	Single hard drive configurations, 6.35 cm (2.5-in), SATA hard drives:
	2 TB, 5400 rpm, 9.5 mm
	2 TB, 5400 rpm, 7.2 mm
	1 TB, 5400 rpm, 9.5 mm
	1 TB, 5400 rpm, 7.2 mm
	500 GB, 5400 rpm, 7.0 mm
	M.2, SATA-3, solid-state drives:
	256 GB, TLC
	128 GB, TLC

Category	Description
	<p>PCIe, NVMe, M.2 solid-state drives (Intel Core processors):</p> <p>512 GB</p> <p>256 GB</p> <p>Dual storage configurations (Intel Core processors):</p> <p>256 GB, PCIe, solid-state drive + 1 TB, 5400 rpm hard drive</p> <p>256 GB, SATA-3, TLC, solid-state drive + 1 TB, 5400 rpm hard drive</p> <p>128 GB, SATA-3, TLC, solid-state drive + 1 TB, 5400 rpm hard drive</p> <p>Optane configuration (Intel Core processors):</p> <p>16 GB, PCIe, Optane solid-state drive + 1 TB, 5400 rpm, 7.2 mm/9.5 mm hard drive</p>
Optical drive	<p>9.0 mm tray load</p> <p>DVD+/-RW Double-Layer Writer</p>
Camera	<p>HP TrueVision HD Camera - indicator LED, USB2.0, HD BSI sensor, f2.0</p> <p>720p by 30 frames per second</p> <p>Single digital microphone</p> <p>HP Webcam - VGA camera, indicator LED, USB 2.0, f2.4</p> <p>640×480 by 30 frames per second</p> <p>Single digital microphone</p>
Audio	<p>Audio Application Name: HP Audio Control</p> <p>Dual speakers</p>
Ethernet	Ethernet Integrated 10/100/1000 NIC
Wireless networking	<p>Compatible with Miracast-certified devices</p> <p>Integrated Wireless options with dual antennas (M.2/PCIe):</p> <p>Intel Dual band wireless-AC 3168 802.11AC 1×1 WiFi + Bluetooth 4.2 Combo Adaptor (non-vPro)</p> <p>Realtek RTL8822BE 802.11 ac 2×2 WiFi + Bluetooth 4.2 Combo Adapter (MU-MIMO supported)</p> <p>Integrated Wireless options with single antenna (M.2/PCIe):</p> <p>Intel Dual Band Wireless-AC 9461 802.11 AC 1×1 WiFi + BT5 Combo Adapter (non-vPro) (MU-MIMO supported)</p> <p>Realtek RTL8821CE 802.11 ac 1×1 WiFi + Bluetooth 4.2 Combo Adapter (MU-MIMO supported)</p> <p>Realtek RTL8723DE 802.11 bgn 1×1 WiFi + Bluetooth 4.2 Combo Adapter</p>
External media cards	<p>HP Multi-Format Digital Media Card Reader</p> <p>Supports SD/SDHC/SDXC</p> <p>Push-pull insertion/removal</p>
Internal card expansion	<p>One M.2 slot for solid-state drive (Intel Core processors)</p> <p>One M.2 slot for WLAN</p>
Ports	Hot plug/unplug and auto detect for correct output to wide-aspect vs. standard aspect video (auto adjust panel resolution to fit embedded panel and external monitor connected)

Category	Description
	HDMI v1.4 supporting: up to 1920×1080 @ 60Hz
	USB 2.0 port (right side)
	(2) USB 3.1 Gen 1 Type-A ports (left side)
	RJ-45/Ethernet
	Audio-out (headphone)/audio-in (microphone) combo jack
	AC Smart Pin adapter plug
Keyboard/pointing devices	Keyboard:
	Full-size, textured, island-style keyboard with numeric keypad
	Full-size, two coat paint, backlit, island-style keyboard with numeric keypad
	Full-size, three coat paint, backlit, island-style keyboard with numeric keypad
	Full-size, four coat paint, backlit, island-style keyboard with numeric keypad
	TouchPad:
	Multitouch gestures enabled
	Support Modern Trackpad Gestures
	Taps enabled by default
Power requirements	Battery:
	3-cell battery, 41 Whr
	Supports battery fast charge
	AC adapter, barrel type:
	65 W Smart, nPFC, right angle, 4.5 mm (models with discrete graphics)
	65 W Smart, nPFC, right angle, 4.5 mm for use in Argentina (models with discrete graphics)
	65 W Smart, nPFC, 4.5 mm, EM
	45 W Smart, nPFC, right angle, 4.5 mm (models with UMA graphics)
	45 W Smart, nPFC, right angle, 4.5 mm, for use in Argentina (models with UMA graphics)
	Power cord (C5):
	1 m, conventional
Security	Kensington Security Lock
	Supports firmware-based Trusted Platform Module (fTPM) 2.0
Operating system	FreeDOS 2.0
	Windows 10 Home 64
	Windows 10 Home 64 Chinese Market CPPP
	Windows 10 Home 64 High-End Chinese Market CPPP
	Windows 10 Home 64 Plus
	Windows 10 Home 64 Plus QVC







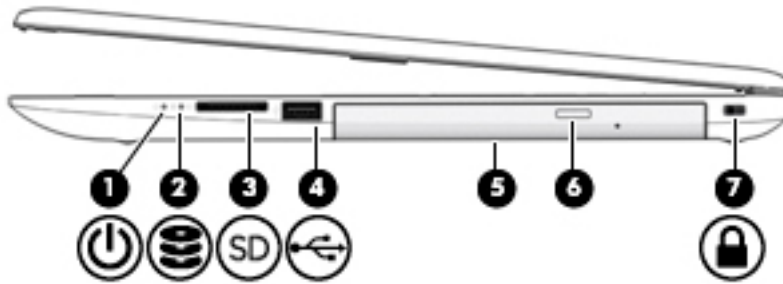

Category	Description
	Windows 10 Home 64 Plus Single Language
	Windows 10 Home 64 Plus Single Language APAC EM PPP
	Windows 10 Home 64 Plus Single Language India Market PPP
	Windows 10 Home 64 Plus Single Language Indonesia Market PPP
	Windows 10 Home 64 Plus Web/Kiosk
	Windows 10 Home 64 QVC
	Windows 10 Home 64 Single Language
	Windows 10 Home 64 Single Language APAC EM PPP
	Windows 10 Home 64 Single Language India Market PPP
	Windows 10 Home 64 Single Language Indonesia Market PPP
	Windows 10 Home 64 Single Language Value APAC EM PPP
	Windows 10 Home 64 Single Language Value India Market PPP (Intel Pentium and Celeron processors only)
	Windows 10 Home 64 Single Language Value Indonesia Market PPP
	Windows 10 Home 64 Value Notebook Single Language (Intel Pentium and Celeron processors only)
	Windows 10 Home 64 Value Notebook Single Language SEAP (Intel Pentium and Celeron processors only)
	Windows 10 Home 64 Value Notebook Single Language select GEO (Intel Pentium and Celeron processors only)
	Windows 10 Home 64 Web/Kiosk
	Windows 10 Pro 64
	Windows 10 Pro 64 Web/Kiosk
Serviceability	End user replaceable parts:
	AC adapter
	Optical drive

2 Getting to know your computer

Your computer features top-rated components. This chapter provides details about your components, where they are located, and how they work.





Right side

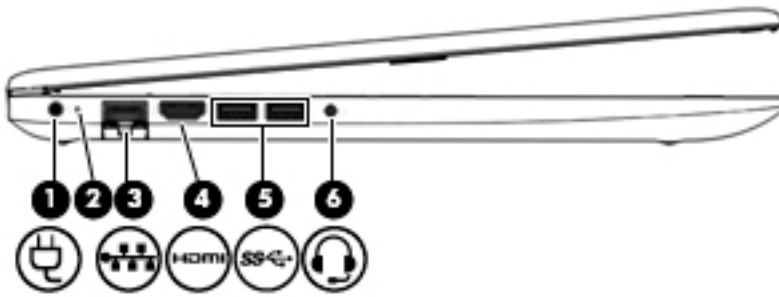

Component	Description
(1)  Power light	<ul style="list-style-type: none">On: The computer is on.Blinking: The computer is in the Sleep state, a power-saving state. The computer shuts off power to the display and other unneeded components.Off: The computer is off or in Hibernation. Hibernation is a power-saving state that uses the least amount of power.
(2)  Drive light	<ul style="list-style-type: none">Blinking white: The hard drive is being accessed.
(3)  Memory card reader	<p>Reads optional memory cards that enable you to store, manage, share, or access information.</p> <p>To insert a card:</p> <ol style="list-style-type: none">Hold the card label-side up, with connectors facing the computer.Insert the card into the memory card reader, and then press in on the card until it is firmly seated. <p>To remove a card:</p> <ul style="list-style-type: none"> Pull to remove the card from the memory card reader.
(4)  USB port	Connects a USB device, such as a cell phone, camera, activity tracker, or smartwatch, and provides data transfer.
(5)  Optical drive	Depending on your computer model, reads an optical disc or reads and writes to an optical disc.
(6)  Optical drive eject button	Releases the optical drive disc tray.
(7)  Security cable slot	Attaches an optional security cable to the computer. NOTE: The security cable is designed to act as a deterrent, but it may not prevent the computer from being mishandled or stolen.

Left side



Component	Description
(1) 	Connects an AC adapter.
(2)	<p>AC adapter and battery light</p> <ul style="list-style-type: none"> White: The AC adapter is connected and the battery is fully charged. Blinking white: The AC adapter is disconnected and the battery has reached a low battery level. Amber: The AC adapter is connected and the battery is charging. Off: The battery is not charging.
(3) 	<p>RJ-45 (network) jack/status lights</p> <p>Connects a network cable.</p> <ul style="list-style-type: none"> White: The network is connected. Amber: Activity is occurring on the network.
(4) 	<p>HDMI port</p> <p>Connects an optional video or audio device, such as a high-definition television, any compatible digital or audio component, or a high-speed High-Definition Multimedia Interface (HDMI) device.</p>
(5) 	<p>USB SuperSpeed ports (2)</p> <p>Connect a USB device, such as a cell phone, camera, activity tracker, or smartwatch, and provide high-speed data transfer.</p>
(6) 	<p>Audio-out (headphone)/Audio-in (microphone) combo jack</p> <p>Connects optional powered stereo speakers, headphones, earbuds, a headset, or a television audio cable. Also connects an optional headset microphone. This jack does not support optional standalone microphones.</p> <p>WARNING! To reduce the risk of personal injury, adjust the volume before putting on headphones, earbuds, or a headset. For additional safety information, see the <i>Regulatory, Safety, and Environmental Notices</i>.</p> <p>To access this guide:</p> <ul style="list-style-type: none"> ▲ Select the Start button, select HP Help and Support, and then select HP Documentation. <p>NOTE: When a device is connected to the jack, the computer speakers are disabled.</p>

Display

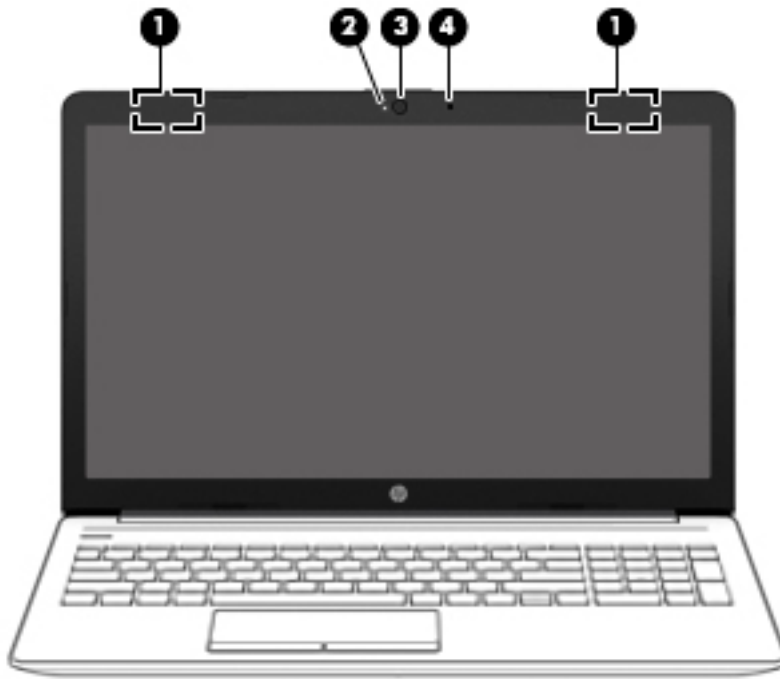

Component	Description
(1) WLAN antennas* (1 or 2 depending on model)	Send and receive wireless signals to communicate with wireless local area networks (WLANs).
(2) Camera light	On: The camera is in use.
(3) Camera	Allows you to video chat, record video, and record still images. Some cameras also allow a facial recognition logon to Windows, instead of a password logon.. NOTE: Camera functions vary depending on the camera hardware and software installed on your product.
(4) Internal microphone	Records sound.

*The antennas are not visible from the outside of the computer. For optimal transmission, keep the areas immediately around the antennas free from obstructions.

For wireless regulatory notices, see the section of the *Regulatory, Safety, and Environmental Notices* that applies to your country or region.

To access this guide:

1. Type `support` in the taskbar search box, and then select the **HP Support Assistant** app.

– or –

Click the question mark icon in the taskbar.

2. Select **My PC**, select the **Specifications** tab, and then select **User Guides**.

Keyboard area

TouchPad



Component		Description
(1)	TouchPad zone	Reads your finger gestures to move the pointer or activate items on the screen.
(2)	Left TouchPad button	Functions like the left button on an external mouse.
(3)	Right TouchPad button	Functions like the right button on an external mouse.

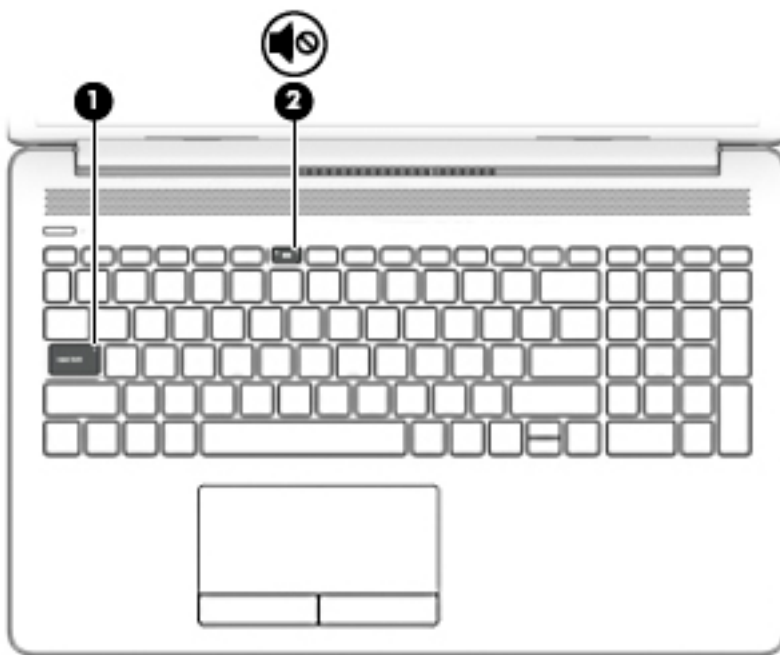

Lights

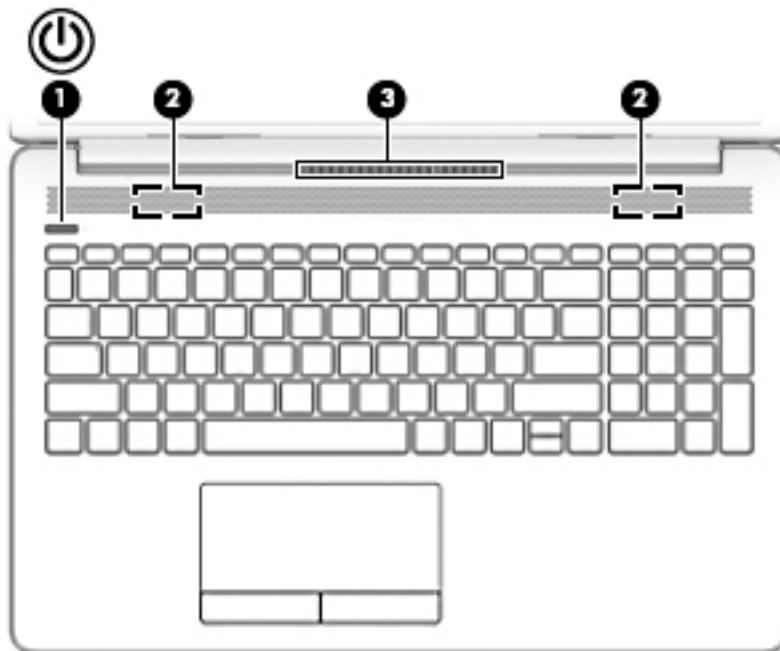

Component	Description
(1) Caps lock light	On: Caps lock is on, which switches the key input to all capital letters.
(2)  Mute light	<ul style="list-style-type: none">• On: Computer sound is off.• Off: Computer sound is on.

Button and speakers



Component	Description
(1)  Power button	<ul style="list-style-type: none"> • When the computer is off, press the button to turn on the computer. • When the computer is on, press the button briefly to initiate Sleep. • When the computer is in the Sleep state, press the button briefly to exit Sleep. • When the computer is in Hibernation, press the button briefly to exit Hibernation. <p>CAUTION: Pressing and holding down the power button results in the loss of unsaved information.</p> <p>If the computer has stopped responding and shutdown procedures are ineffective, press and hold the power button down for at least 5 seconds to turn off the computer.</p> <p>To learn more about your power settings, see your power options:</p> <ul style="list-style-type: none"> ▲ Right-click the Power icon , and then select Power Options.
(2) Speakers (2)	Produce sound.
(3) Vent	Enables airflow to cool internal components.

NOTE: The computer fan starts up automatically to cool internal components and prevent overheating. It is normal for the internal fan to cycle on and off during routine operation.

Special keys

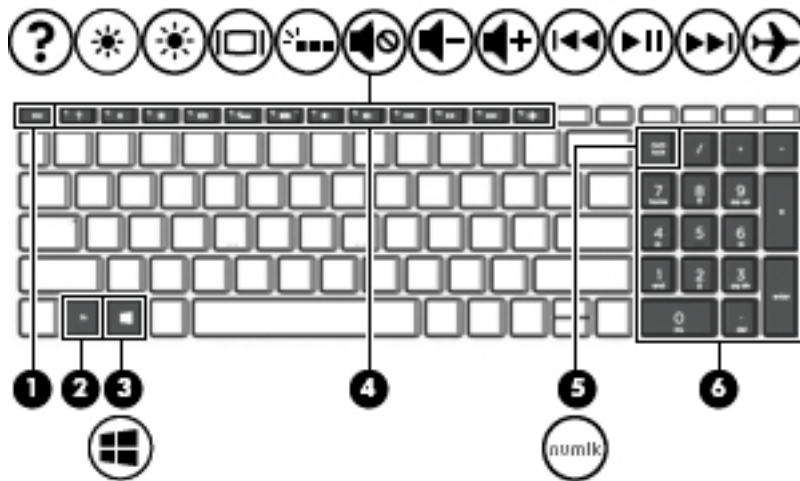













Component	Description
(1) esc key	Displays system information when pressed in combination with the fn key.
(2) fn key	Executes specific functions when pressed in combination with another key.
(3)  Windows key	Opens the Start menu. NOTE: Pressing the Windows key again will close the Start menu.
(4) Action keys	Execute frequently used system functions. NOTE: On select products, the f5 action key turns the keyboard backlight feature off or on.
(5) num lock key	Alternates between the navigational and numeric functions on the integrated numeric keypad.
(6) Integrated numeric keypad	A separate keypad to the right of the alphabet keyboard. When num lock is pressed, the keypad can be used like an external numeric keypad. NOTE: If the keypad function is active when the computer is turned off, that function is reinstated when the computer is turned back on.

Action keys

An action key performs the function indicated by the icon on the key. To determine which keys are on your product, see [Special keys on page 12](#).

- ▲ To use an action key, press and hold the key.

Icon	Description
	Opens the “How to get help in Windows 10” webpage.
	Decreases the screen brightness incrementally as long as you hold down the key.
	Increases the screen brightness incrementally as long as you hold down the key.
	Switches the screen image between display devices connected to the system. For example, if a monitor is connected to the computer, repeatedly pressing this key alternates the screen image from the computer display to the monitor display to a simultaneous display on both the computer and the monitor.
	Turns the keyboard backlight off or on. NOTE: To conserve battery power, turn off this feature.
	Mutes or restores speaker sound.
	Decreases speaker volume incrementally while you hold down the key.
	Increases speaker volume incrementally while you hold down the key.
	Plays the previous track of an audio CD or the previous section of a DVD or a Blu-ray Disc (BD).
	Starts, pauses, or resumes playback of an audio CD, a DVD, or a BD.
	Plays the next track of an audio CD or the next section of a DVD or a BD.
	Turns the airplane mode and wireless feature on or off. NOTE: The airplane mode key is also referred to as the wireless button. NOTE: A wireless network must be set up before a wireless connection is possible.

Bottom



Component

Vent

Description

Enables airflow to cool internal components.

NOTE: The computer fan starts up automatically to cool internal components and prevent overheating. It is normal for the internal fan to cycle on and off during routine operation.

Labels

The labels affixed to the computer provide information you may need when you troubleshoot system problems or travel internationally with the computer. Labels may be in paper form or imprinted on the product.

 **IMPORTANT:** Check the following locations for the labels described in this section: the bottom of the computer, inside the battery bay, under the service door, on the back of the display, or on the bottom of a tablet kickstand.

- Service label—Provides important information to identify your computer. When contacting support, you may be asked for the serial number, the product number, or the model number. Locate this information before you contact support.

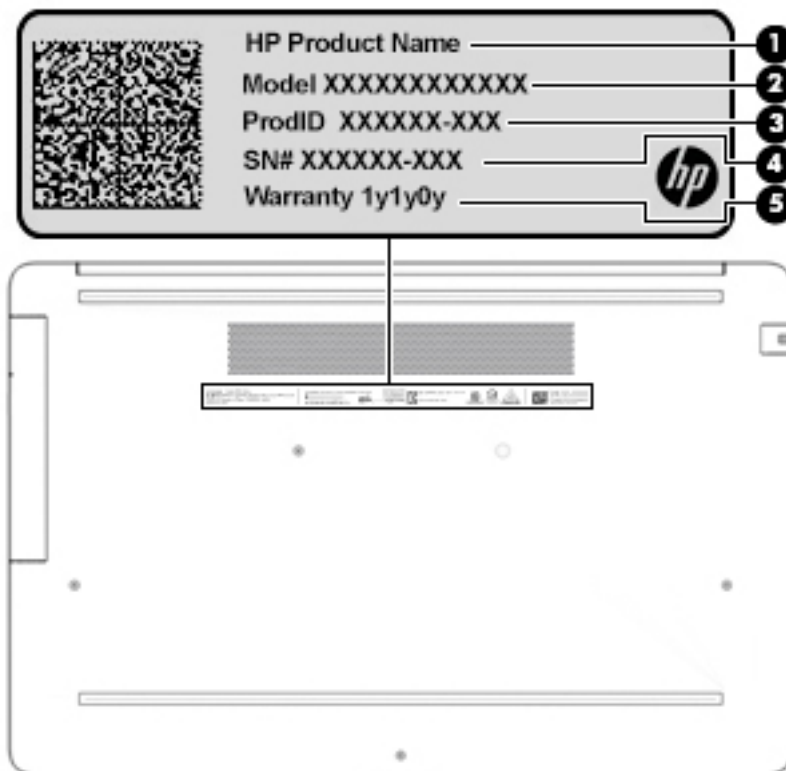

Component

- | | |
|-----|-----------------|
| (1) | HP product name |
| (2) | Model number |
| (3) | Product ID |
| (4) | Serial number |
| (5) | Warranty period |

- Regulatory label(s)—Provide(s) regulatory information about the computer.
- Wireless certification label(s)—Provide(s) information about optional wireless devices and the approval markings for the countries or regions in which the devices have been approved for use.

3 Illustrated parts catalog

Computer major components

 **NOTE:** HP continually improves and changes product parts. For complete and current information on supported parts for your computer, go to <http://partsurfer.hp.com>, select your country or region, and then follow the on-screen instructions.

 **NOTE:** Details about your computer, including model, serial number, product key, and length of warranty, are on the service tag at the bottom of your computer. See [Labels on page 15](#) for details.

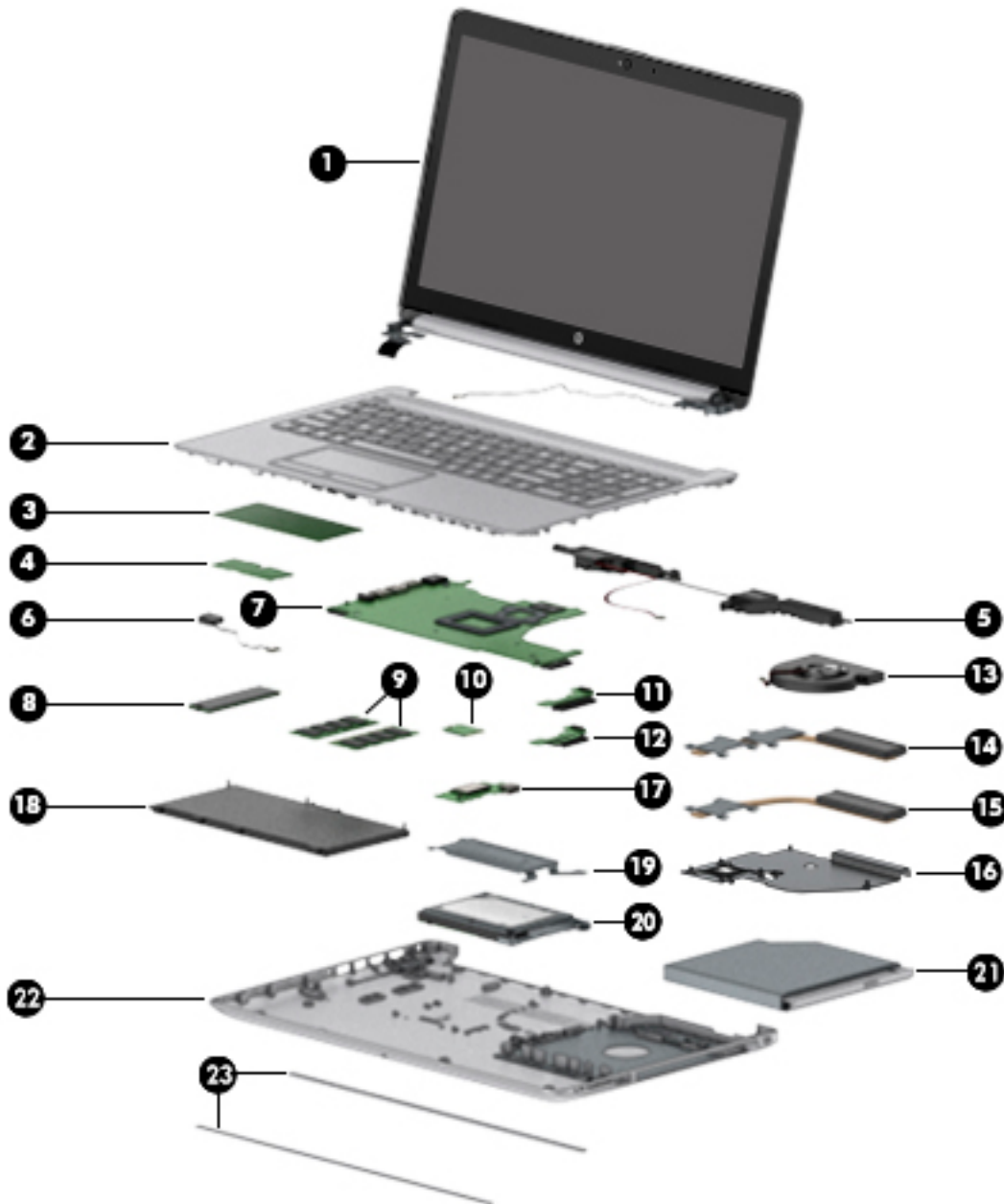

Item	Component	Spare part number
(1)	Display NOTE: Displays are not spared as whole units. Display subcomponent spare parts are available. For spare part information, see Display assembly subcomponents on page 22 .	Not spared
(2)	Top cover/keyboard NOTE: For a detailed list of country codes, see Top cover with keyboard on page 77 .	
	Keyboard, no backlight, jet black	L20387-xx1
	Keyboard, no backlight, full-featured models, snow white	L20388-xx1
	Keyboard, no backlight, defeatured models, snow white	L23066-xx1
	Keyboard, no backlight, ash silver	L20386-xx1
	Keyboard, backlit, ash silver (available only with -001 United States, -002 India, and -DB1 Canadian French keyboards)	L23074-xx1
	Keyboard, no backlight, iridescent pale rose gold (available only with -001 United States keyboards)	L28504-001
	Keyboard, backlit, iridescent pale rose gold (available only with -001 United States keyboards)	L28505-001
	Keyboard, no backlight, iridescent ceramic white (available only with -001 United States keyboards)	L28506-001
	Keyboard, backlit, iridescent ceramic white (available only with -001 United States keyboards)	L28507-001
	Keyboard, no backlight, ocean teal (available only with -001 United States keyboards)	L31735-001
	Keyboard, backlit, ocean teal (available only with -001 United States keyboards)	L32863-001
	Keyboard, no backlight, real tree (available only with -001 United States keyboards)	L31736-001
	Keyboard, no backlight, natural silver (available only with -002 India keyboards)	L32368-002
	Keyboard, backlit, natural silver (available only with -002 India keyboards)	L32864-002
(3)	TouchPad module	L20449-001
(4)	TouchPad button board	not spared
(5)	Speakers (includes cable)	L20453-001
(6)	Power connector cable (DC-in)	L20475-001
(7)	System board NOTE: All system board spare part kits include replacement thermal material. All system boards use the following part numbers: xxxxxx-001: Non-Windows operating systems xxxxxx-601: Windows operating system For use in models with discrete graphics memory:	
	• Intel Core i7-8565U processor with 4 GB of discrete graphics memory	L35243-xx1
	• Intel Core i7-8565U processor with 2 GB of discrete graphics memory	L35241-xx1
	• Intel Core i7-8550U processor with 4 GB of discrete graphics memory	L20368-xx1
	• Intel Core i7-8550U processor with 2 GB of discrete graphics memory	L20364-xx1

Item	Component	Spare part number
	• Intel Core i5-8265U processor with 4 GB of discrete graphics memory	L35242-xx1
	• Intel Core i5-8265U processor with 2 GB of discrete graphics memory	L35240-xx1
	• Intel Core i5-8250U processor with 4 GB of discrete graphics memory	L20367-xx1
	• Intel Core i5-8250U processor with 2 GB of discrete graphics memory	L20362-xx1
	• Intel Core i7-7500U processor with 2 GB of discrete graphics memory	L20363-xx1
	• Intel Core i5-7200U processor with 2 GB of discrete graphics memory	L36493-xx1
	• Intel Core i3-7100U processor with 2 GB of discrete graphics memory	L36492-xx1
	• Intel Core i3-7020U processor with 2 GB of discrete graphics memory	L20365-xx1
	• Intel Pentium N5000 processor with 2 GB of discrete graphics memory	L20366-xx1
	For use in models with UMA graphics memory:	
	• Intel Core i7-8550U processor	L20371-xx1
	• Intel Core i5-8265U processor	L35245-xx1
	• Intel Core i5-8250U processor	L20369-xx1
	• Intel Core i3-8145U processor	L35244-xx1
	• Intel Core i3-8130U processor	L20374-xx1
	• Intel Core i7-7500U processor	L20370-xx1
	• Intel Core i5-7200U processor	L36494-xx1
	• Intel Core i3-7100U processor	L35239-xx1
	• Intel Core i3-7020U processor	L20373-xx1
	• Intel Pentium N5000 processor	L20375-xx1
	• Intel Celeron N4000 processor	L20372-xx1
(8)	Solid-state drive	
	NOTE: For spare part information, see Mass storage devices on page 26 .	
(9)	Memory modules (2400 MHz DDR4)	
	8 GB	862398-855
	4 GB	862397-855
(10)	WLAN module	
	Intel Dual band wireless-AC 3168 802.11AC 1×1 WiFi + Bluetooth 4.2 Combo Adapter (non-vPro)	863934-855
	Realtek RTL8822BE 802.11 ac 2×2 WiFi + Bluetooth 4.2 Combo Adapter (MU-MIMO supported)	924813-855
	Realtek RTL8821CE 802.11 ac 1×1 WiFi + Bluetooth 4.2 Combo Adapter (MU-MIMO supported)	L17365-005
	Realtek RTL8723DE 802.11 bgn 1×1 WiFi + Bluetooth 4.2 Combo Adapter	L21480-005
(11)	Hard drive connector board	L20454-001
(12)	Solid-state drive connector board	L20457-001
(13)	Fan	

Item	Component	Spare part number
	Fan for use in models with discrete graphics	L20473-001
	Fan for use in models with UMA graphics	L20474-001
	Heat sink	
(14)	Heat sink for use in models with i7-8550, i5-8250, i3-8130U, i7-7500U, i3-7020U processors and integrated discrete graphics memory	L20469-001
	Heat sink for use in models with i7-8565U, i5-8265U, i3-8145U processors and discrete graphics memory	L36498-001
	Heat sink for use in models with an Intel Pentium or Celeron processor and discrete graphics	L20471-001
(15)	Heat sink for use in models with i7-8550, i5-8250, i3-8130U, i7-7500U, i3-7020U processors and UMA graphics memory	L20470-001
(16)	Heat sink for use in fanless models with an Intel Pentium or Celeron processor and UMA graphics (not illustrated)	L20472-001
(17)	USB/card reader board The USB/card reader board cable is available using spare part number L20452-001.	L20448-001
(18)	Battery (3-cell, 48 WHr)	L11119-855
(19)	Solid-state drive bracket	L20458-001
(20)	Hard drive NOTE: For spare part information, see Mass storage devices on page 26 .	
(21)	DVD+/-RW Double-Layer Writer	L20485-001
(22)	Bottom cover For use in models with an optical drive	
	• Snow white	L20389-001
	• Jet black	L20390-001
	• Natural silver	L20391-001
	• Pale gold	L20392-001
	• Twilight blue	L20393-001
	• Scarlet red	L20397-001
	• Smoke gray	L20395-001
	• Maroon burgundy	L20398-001
	• Iridescent pale rose gold	L28510-001
	• Iridescent ceramic white	L28512-001
	• Ocean teal	L31725-001
	• Real tree	L31726-001
	For use in models without an optical drive	
	• Snow white	L20399-001
	• Jet black	L20400-001

Item	Component	Spare part number
	• Natural silver	L20401-001
	• Pale gold	L20402-001
	• Twilight blue	L20403-001
	• Scarlet red	L20405-001
	• Smoke gray	L20404-001
	• Iridescent pale rose gold	L28511-001
	• Iridescent ceramic white	L28513-001
	• Maroon burgundy	L31719-001
(23)	Rubber feet	
	Front feet:	
	• Pale gold	L20408-001
	• Scarlet red	L20411-001
	• Twilight blue	L20409-001
	• Maroon burgundy	L20412-001
	• Dark ash silver	L20406-001
	• Asteroid silver	L20407-001
	• Iridescent pale rose gold	L28518-001
	• Iridescent ceramic white	L28520-001
	• Ocean teal	L31731-001
	• Real tree	L31732-001
	Rear feet:	
	• Pale gold	L20415-001
	• Scarlet red	L20418-001
	• Twilight blue	L20416-001
	• Maroon burgundy	L20419-001
	• Dark ash silver	L20413-001
	• Asteroid silver	L20414-001
	• Iridescent pale rose gold	L28519-001
	• Iridescent ceramic white	L28521-001
	• Ocean teal	L31733-001
	• Real tree	L31734-001

Cables

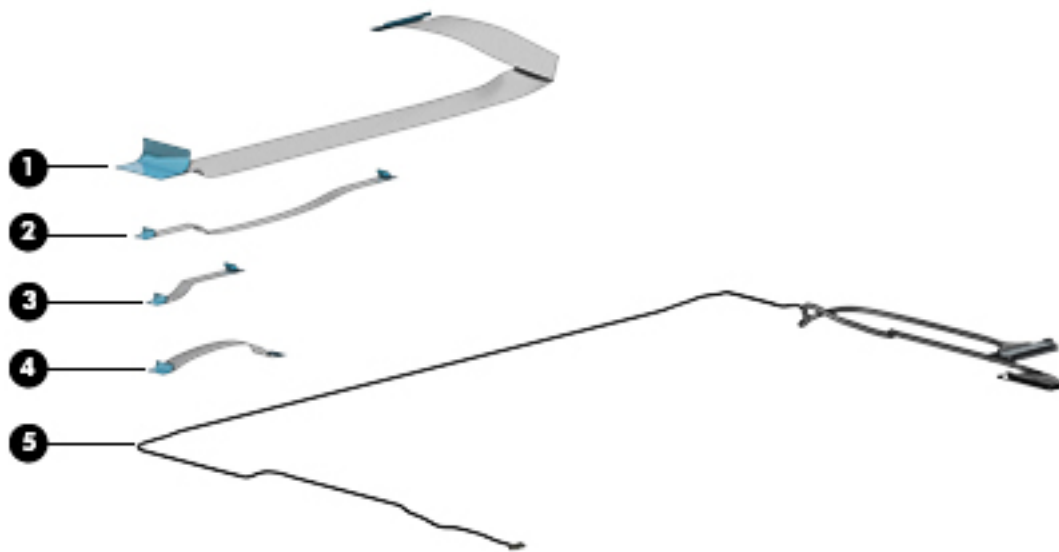

Item	Component	Spare part number
(1)	USB/card reader board cable	L20452-001
(2)	TouchPad button board cable	L20451-001
(3)	TouchPad cable	L20450-001
(4)	Hard drive/solid-state drive cable	L20456-001
(5)	Display cable	
	Display cable, non-touch, HD	L20443-001
	Display cable, non-touch, FHD	L23064-001
	Display cable, touch, HD	L20442-001

Display assembly subcomponents

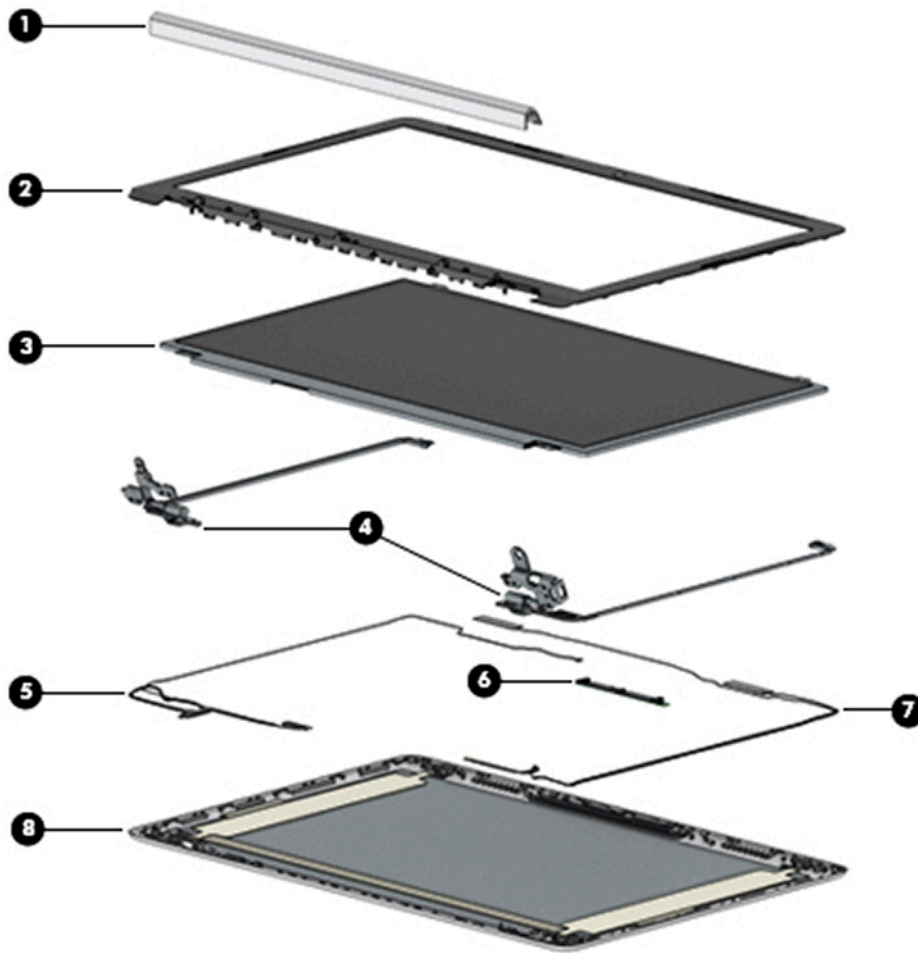

Item	Component	Spare part number
(1)	Hinge cover	
	Jet black	L20423-001
	Sparkling black	L20427-001
	Natural silver	L20424-001
	Pale gold	L20425-001
	Scarlet red	L20430-001
	Twilight blue	L20426-001
	Smoke gray	L20428-001
	Snow white (full-featured models)	L20422-001
	Snow white (defeatured) models	L21306-001
	Maroon burgundy	L20431-001
	Iridescent pale rose gold	L28516-001
	Iridescent ceramic white	L28517-001

Item	Component	Spare part number
	Ocean teal	L31729-001
	Real tree	L31730-001
(2)	Display bezel	L20421-001
	NOTE: The display bezel for real tree models is available using spare part number L32367-001.	
(3)	Display panel	
	HD, BrightView, non-touch	L20379-001
	HD, anti glare, non-touch	L20378-001
	HD, BrightView, touch-on panel (TOP)	L20380-001
	FHD, anti glare, non-touch	L20376-001
	FHD, anti glare, narrow bezel	L20377-001
	Miscellaneous Display Kit (includes gaskets [4] and rubber corner positioning tools [4]; not illustrated)	L23065-001
	Display panel stretchable adhesive tape (not illustrated)	L29080-001
(4)	Hinge Kit (includes left and right hinges)	L20420-001
(5)	Display cable	
	Non-touch, HD	L20443-001
	Non-touch, FHD	L23064-001
	Touch, HD	L20442-001
(6)	Camera module	
	HD camera	L20447-001
	VGA camera	L20446-001
(7)	WLAN antenna cable	
	Single antenna	L20445-001
	Single antennas, narrow bezel	L23060-001
	Dual antennas	L20444-001
	Dual antennas, narrow bezel	L23059-001
(8)	Back cover	
	Jet black	L20433-001
	Jet black (narrow bezel models)	L23061-001
	Sparkling black	L20437-001
	Natural silver	L20434-001
	Natural silver (narrow bezel models)	L23062-001
	Pale gold	L20435-001
	Scarlet red	L20440-001

Item	Component	Spare part number
	Twilight blue	L20436-001
	Smoke gray	L20438-001
	Smoke gray (narrow bezel models)	L23063-001
	Snow white (full-featured models)	L20432-001
	Snow white (defeatured models)	L21307-001
	Maroon burgundy	L20441-001
	Iridescent pale rose gold	L28508-001
	Iridescent ceramic white	L28509-001
	Ocean teal	L31723-001
	Real tree	L31724-001

Miscellaneous parts

Component	Spare part number
AC adapter	
65 W AC adapter, nPFC, 4.5 mm	710412-001
65 W AC adapter, nPFC, SMART, RC, 4.5 mm, EM	913691-850
65 W AC adapter, nPFC, 4.5 mm for use in Argentina	710340-850
45 W AC adapter, nPFC, SMART, RC, 4.5 mm, non-slim	741727-001
45 W AC adapter, nPFC, SMART, RC, 4.5 mm for use in Argentina	741553-852
Power cord, C5, conventional, 1.0 m	
For use in Argentina	L19357-001
For use in Australia	L19358-001
For use in Denmark	L19360-001
For use in Europe	L19361-001
For use in India	L19363-001
For use in Israel	L19362-001
For use in Italy	L19364-001
For use in Japan	L19365-001
For use in North America	L19367-001
For use in the People's Republic of China	L19368-001
For use in South Africa	L19369-001
For use in South Korea	L19366-001
For use in Switzerland	L19370-001
For use in Taiwan	L19372-001
For use in Thailand	L19371-001
For use in the United Kingdom	L19373-001
Screw Kit	L20476-001
HP HDMI to VGA Adapter	701943-001

Mass storage devices

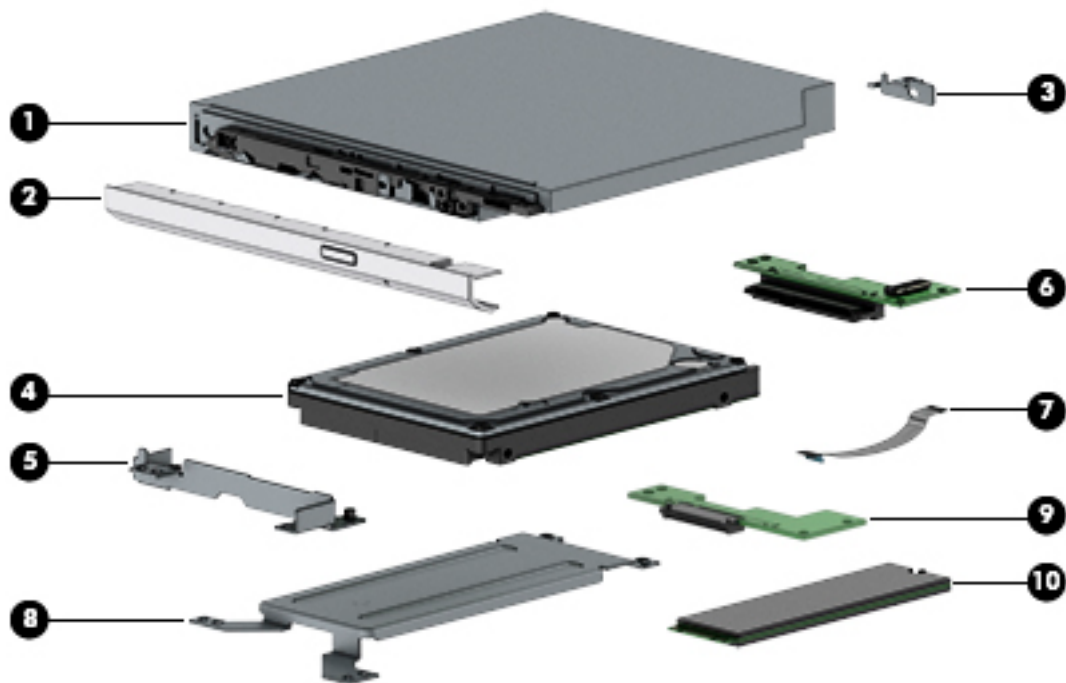

Item	Component	Spare part number
(1)	DVD+/-RW Double-Layer Writer	L20485-001
(2)	Optical drive bezel	
	Natural silver	L20462-001
	Pale gold	L20463-001
	Scarlet red	L20467-001
	Smoke gray	L20465-001
	Twilight blue	L20464-001
	Maroon burgundy	L20468-001
	Jet black	L20461-001
	Snow white	L20460-001
	Iridescent pale rose gold	L28514-001
	Iridescent ceramic white	L28515-001
	Ocean teal	L31727-001
	Real tree	L31728-001
(3)	Optical drive bracket	L20459-001
(4)	Hard drive, 7 mm	
	2 TB, 5400 rpm	912487-855
	1 TB, 5400 rpm	762990-005

Item	Component	Spare part number
	500 GB, 5400 rpm	778186-005
(5)	Hard drive bracket	L20455-001
(6)	Hard drive connector board	L20454-001
(7)	Hard drive/solid-state drive cable	L20456-001
(8)	Solid-state drive bracket	L20458-001
(9)	Solid-state drive connector board	L20457-001
(10)	Solid-state drive (M.2)	
	512 GB, PCIe, NVMe	L20385-001
	256 GB, PCIe, NVMe	L20384-001
	256 GB, SATA-3, TLC	L20382-001
	128 GB, SATA-3, TLC	L20381-001
	Optane memory module, 16 GB	L20383-001

4 Removal and replacement procedures preliminary requirements

Tools required

You will need the following tools to complete the removal and replacement procedures:

- Phillips P1 magnetic screwdriver
- Plastic, non-marking pry tool

Service considerations

The following sections include some of the considerations that you must keep in mind during disassembly and assembly procedures.



NOTE: As you remove each subassembly from the computer, place the subassembly (and all accompanying screws) away from the work area to prevent damage.

Plastic parts



CAUTION: Using excessive force during disassembly and reassembly can damage plastic parts. Use care when handling the plastic

Cables and connectors

⚠ CAUTION: When servicing the computer, be sure that cables are placed in their proper locations during the reassembly process. Improper cable placement can damage the computer.

Cables must be handled with extreme care to avoid damage. Apply only the tension required to unseat or seat the cables during removal and insertion. Handle cables by the connector whenever possible. In all cases, avoid bending, twisting, or tearing cables. Be sure that cables are routed in such a way that they cannot be caught or snagged by parts being removed or replaced. Handle flex cables with extreme care; these cables tear easily.

Drive handling

⚠ CAUTION: Drives are fragile components that must be handled with care. To prevent damage to the computer, damage to a drive, or loss of information, observe these precautions:

Before removing or inserting a hard drive, shut down the computer. If you are unsure whether the computer is off or in Hibernation, turn the computer on, and then shut it down through the operating system.

Before handling a drive, be sure that you are discharged of static electricity. While handling a drive, avoid touching the connector.

Before removing an optical drive, be sure that a disc is not in the drive and be sure that the optical drive tray is closed.

Handle drives on surfaces covered with at least one inch of shock-proof foam.

Avoid dropping drives from any height onto any surface.

After removing a hard drive or an optical drive, place it in a static-proof bag.

Avoid exposing an internal hard drive to products that have magnetic fields, such as monitors or speakers.

Avoid exposing a drive to temperature extremes or liquids.

If a drive must be mailed, place the drive in a bubble pack mailer or other suitable form of protective packaging and label the package "FRAGILE."

Grounding guidelines

Electrostatic discharge damage

Electronic components are sensitive to electrostatic discharge (ESD). Circuitry design and structure determine the degree of sensitivity. Networks built into many integrated circuits provide some protection, but in many cases, ESD contains enough power to alter device parameters or melt silicon junctions.

A discharge of static electricity from a finger or other conductor can destroy static-sensitive devices or microcircuitry. Even if the spark is neither felt nor heard, damage may have occurred.

An electronic device exposed to ESD may not be affected at all and can work perfectly throughout a normal cycle. Or the device may function normally for a while, then degrade in the internal layers, reducing its life expectancy.

⚠ CAUTION: To prevent damage to the computer when you are removing or installing internal components, observe these precautions:

Keep components in their electrostatic-safe containers until you are ready to install them.

Before touching an electronic component, discharge static electricity by using the guidelines described in this section.

Avoid touching pins, leads, and circuitry. Handle electronic components as little as possible.

If you remove a component, place it in an electrostatic-safe container.

The following table shows how humidity affects the electrostatic voltage levels generated by different activities.

⚠ CAUTION: A product can be degraded by as little as 700 V.

Typical electrostatic voltage levels			
Event	Relative humidity		
	10%	40%	55%
Walking across carpet	35,000 V	15,000 V	7,500 V
Walking across vinyl floor	12,000 V	5,000 V	3,000 V
Motions of bench worker	6,000 V	800 V	400 V
Removing DIPS from plastic tube	2,000 V	700 V	400 V
Removing DIPS from vinyl tray	11,500 V	4,000 V	2,000 V
Removing DIPS from plastic foam	14,500 V	5,000 V	3,500 V
Removing bubble pack from PCB	26,500 V	20,000 V	7,000 V
Packing PCBs in foam-lined box	21,000 V	11,000 V	5,000 V

Packaging and transporting guidelines

Follow these grounding guidelines when packaging and transporting equipment:

- To avoid hand contact, transport products in static-safe tubes, bags, or boxes.
- Protect ESD-sensitive parts and assemblies with conductive or approved containers or packaging.
- Keep ESD-sensitive parts in their containers until the parts arrive at static-free workstations.
- Place items on a grounded surface before removing items from their containers.
- Always be properly grounded when touching a component or assembly.
- Store reusable ESD-sensitive parts from assemblies in protective packaging or nonconductive foam.
- Use transporters and conveyors made of antistatic belts and roller bushings. Be sure that mechanized equipment used for moving materials is wired to ground and that proper materials are selected to avoid static charging. When grounding is not possible, use an ionizer to dissipate electric charges.

Workstation guidelines

Follow these grounding workstation guidelines:

- Cover the workstation with approved static-shielding material.
- Use a wrist strap connected to a properly grounded work surface and use properly grounded tools and equipment.
- Use conductive field service tools, such as cutters, screwdrivers, and vacuums.
- When fixtures must directly contact dissipative surfaces, use fixtures made only of static safe materials.
- Keep the work area free of nonconductive materials, such as ordinary plastic assembly aids and plastic foam.
- Handle ESD-sensitive components, parts, and assemblies by the case or PCM laminate. Handle these items only at static-free workstations.
- Avoid contact with pins, leads, or circuitry.
- Turn off power and input signals before inserting or removing connectors or test equipment.

Equipment guidelines

Grounding equipment must include either a wrist strap or a foot strap at a grounded workstation.

- When seated, wear a wrist strap connected to a grounded system. Wrist straps are flexible straps with a minimum of one megohm $\pm 10\%$ resistance in the ground cords. To provide proper ground, wear a strap snugly against the skin at all times. On grounded mats with banana-plug connectors, use alligator clips to connect a wrist strap.
- When standing, use foot straps and a grounded floor mat. Foot straps (heel, toe, or boot straps) can be used at standing workstations and are compatible with most types of shoes or boots. On conductive floors or dissipative floor mats, use foot straps on both feet with a minimum of one megohm resistance between the operator and ground. To be effective, the conductive equipment must be worn in contact with the skin.

The following grounding equipment is recommended to prevent electrostatic damage:

- Antistatic tape
- Antistatic smocks, aprons, and sleeve protectors
- Conductive bins and other assembly or soldering aids
- Nonconductive foam
- Conductive tabletop workstations with ground cords of one megohm resistance
- Static-dissipative tables or floor mats with hard ties to the ground
- Field service kits
- Static awareness labels
- Material-handling packages
- Nonconductive plastic bags, tubes, or boxes
- Metal tote boxes
- Electrostatic voltage levels and protective materials

The following table lists the shielding protection provided by antistatic bags and floor mats.

Material	Use	Voltage protection level
Antistatic plastics	Bags	1,500 V
Carbon-loaded plastic	Floor mats	7,500 V
Metallized laminate	Floor mats	5,000 V

5 Removal and replacement procedures for Customer Self-Repair parts

This chapter provides removal and replacement procedures for Customer Self-Repair parts.

 **NOTE:** The Customer Self-Repair program is not available in all locations. Installing a part not supported by the Customer Self-Repair program may void your warranty. Check your warranty to determine if Customer Self-Repair is supported in your location.

Component replacement procedures

 **NOTE:** Details about your computer, including model, serial number, product key, and length of warranty, are on the service tag at the bottom of your computer. See [Labels on page 15](#) for details.

 **NOTE:** HP continually improves and changes product parts. For complete and current information on supported parts for your computer, go to <http://partsurfer.hp.com>, select your country or region, and then follow the on-screen instructions.

Preparation for disassembly

See [Removal and replacement procedures preliminary requirements on page 28](#) for initial safety procedures.

1. Turn off the computer. If you are unsure whether the computer is off or in Hibernation, turn the computer on, and then shut it down through the operating system.
2. Disconnect the power from the computer by unplugging the power cord from the computer.
3. Disconnect all external devices from the computer

Optical drive

Description	Spare part number
DVD+/-RW Double-Layer Writer	L20485-001
Optical drive bracket	L20459-001
Optical drive bezel	
• Natural silver	L20462-001
• Pale gold	L20463-001
• Scarlet red	L20467-001
• Smoke gray	L20465-001
• Twilight blue	L20464-001
• Maroon burgundy	L20468-001
• Jet black	L20461-001
• Snow white	L20460-001
• Iridescent pale rose gold	L28514-001
• Iridescent ceramic white	L28515-001
• Ocean teal	L31727-001
• Real tree	L31728-001

Remove the optical drive:

1. Prepare the computer for disassembly ([Preparation for disassembly on page 33](#)).
2. Remove the Phillips M2.5×9.0 screw **(1)** that secures the drive to the computer.

3. Slide the optical drive out of the computer (2).

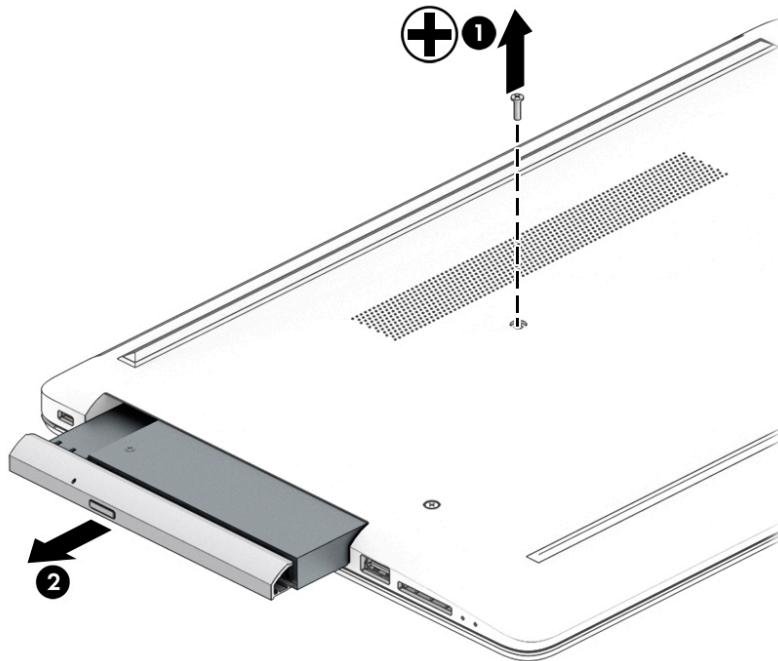

4. If it is necessary to remove the bracket from the rear of the optical drive, remove the Phillips M2.0×3.0 screw (1), and then remove the bracket from the drive (2).

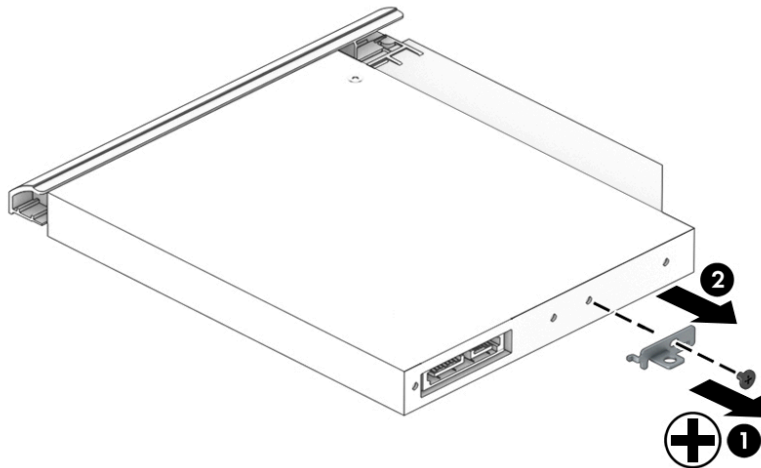

5. If it is necessary to remove the bezel from the front of the optical drive:
 - a. Insert a paper clip into the release hole on the front of the bezel (1). The left side of the bezel rotates outward (2).
 - b. Press the tab to release the bezel from the drive (3).
 - c. Rotate the side of the bezel (4), and then remove it (5).

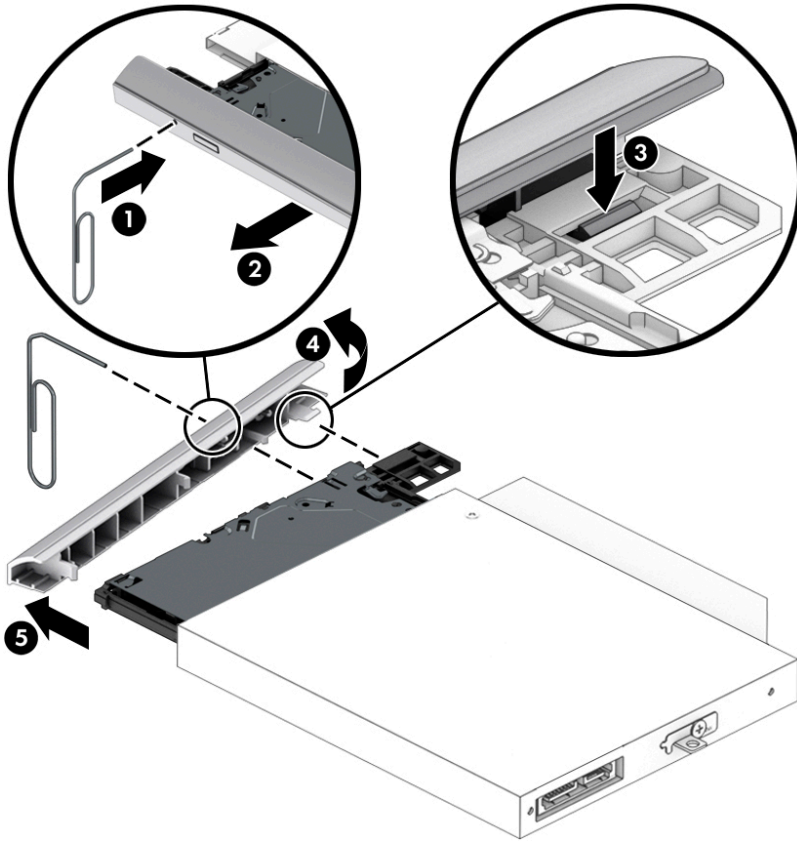

Reverse this procedure to reassemble and install the optical drive.

6 Removal and replacement procedures for Authorized Service Provider parts

This chapter provides removal and replacement procedures for Authorized Service Provider only parts.

 **CAUTION:** Components described in this chapter should only be accessed by an authorized service provider. Accessing these parts can damage the computer or void the warranty.

Component replacement procedures

 **NOTE:** Details about your computer, including model, serial number, product key, and length of warranty, are on the service tag at the bottom of your computer. See [Labels on page 15](#) for details.

 **NOTE:** HP continually improves and changes product parts. For complete and current information on supported parts for your computer, go to <http://partsurfer.hp.com>, select your country or region, and then follow the on-screen instructions.

There are as many as 46 screws that must be removed, replaced, and/or loosened when servicing Authorized Service Provider only parts. Make special note of each screw size and location during removal and replacement.

Bottom cover

Description	Spare part number
Bottom cover for use in models with an optical drive	
• Snow white	L20389-001
• Jet black	L20390-001
• Natural silver	L20391-001
• Pale gold	L20392-001
• Twilight blue	L20393-001
• Scarlet red	L20397-001
• Smoke gray	L20395-001
• Maroon burgundy	L20398-001
• Iridescent pale rose gold	L28510-001
• Iridescent ceramic white	L28512-001
• Ocean teal	L31725-001
• Real tree	L31726-001
Bottom cover for use in models without an optical drive	
• Snow white	L20399-001
• Jet black	L20400-001
• Natural silver	L20401-001
• Pale gold	L20402-001
• Twilight blue	L20403-001
• Scarlet red	L20405-001
• Smoke gray	L20404-001
• Iridescent pale rose gold	L28511-001
• Iridescent ceramic white	L28513-001
• Maroon burgundy	L31719-001
Front feet:	
• Pale gold	L20408-001
• Scarlet red	L20411-001
• Twilight blue	L20409-001
• Maroon burgundy	L20412-001
• Dark ash silver	L20406-001
• Asteroid silver	L20407-001
• Iridescent pale rose gold	L28518-001
• Iridescent ceramic white	L28520-001

Description	Spare part number
<ul style="list-style-type: none"> Ocean teal 	L31731-001
<ul style="list-style-type: none"> Real tree 	L31732-001
Rear feet:	
<ul style="list-style-type: none"> Pale gold 	L20415-001
<ul style="list-style-type: none"> Scarlet red 	L20418-001
<ul style="list-style-type: none"> Twilight blue 	L20416-001
<ul style="list-style-type: none"> Maroon burgundy 	L20419-001
<ul style="list-style-type: none"> Dark ash silver 	L20413-001
<ul style="list-style-type: none"> Asteroid silver 	L20414-001
<ul style="list-style-type: none"> Iridescent pale rose gold 	L28519-001
<ul style="list-style-type: none"> Iridescent ceramic white 	L28521-001
<ul style="list-style-type: none"> Ocean teal 	L31733-001
<ul style="list-style-type: none"> Real tree 	L31734-001

Before removing the bottom cover, follow these steps:

1. Prepare the computer for disassembly ([Preparation for disassembly on page 33](#)).
2. Remove the optical drive (see [Optical drive on page 34](#)).

Remove the bottom cover:

1. Peel the rubber feet off the bottom of the computer **(1)**.
2. Remove the 10 Phillips M2.5×9.0 screws **(2)** that secure the bottom cover to the computer.

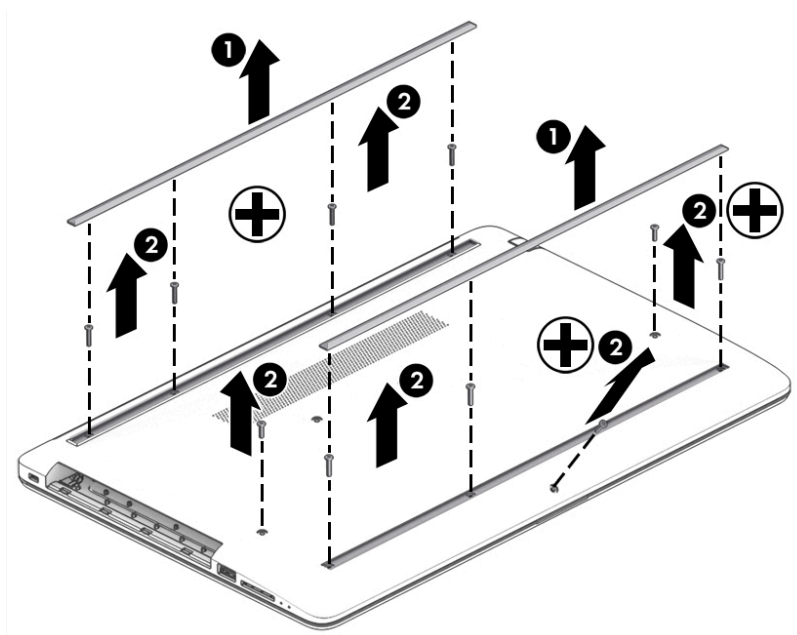

3. Starting near the middle, bottom of the bottom cover **(1)**, pry the cover up to remove it **(2)**.

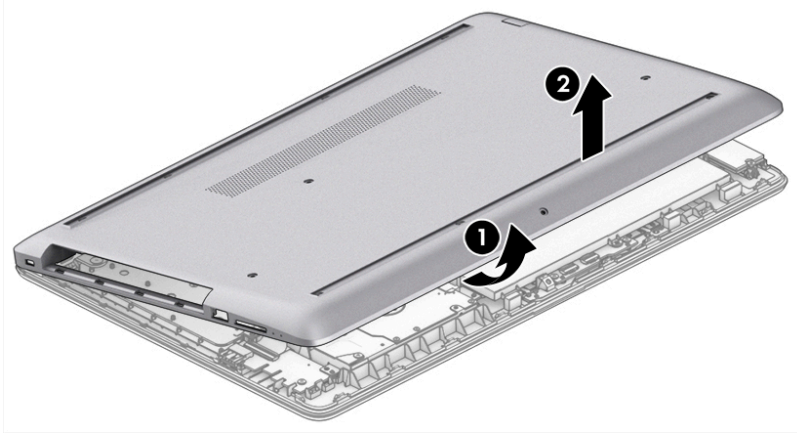

Reverse this procedure to install the bottom cover.

Battery

Description	Spare part number
Battery (3-cell, 41 Wr, 3.6 Ah)	L11119-855

Before removing the battery, follow these steps:

1. Prepare the computer for disassembly ([Preparation for disassembly on page 33](#)).
2. Remove the optical drive (see [Optical drive on page 34](#)).
3. Remove the bottom cover (see [Bottom cover on page 38](#)).

Remove the battery:

1. Remove the three Phillips M2.0×8.0 screws **(1)** that secure the battery to the computer.
2. Remove the battery from the computer **(2)**.

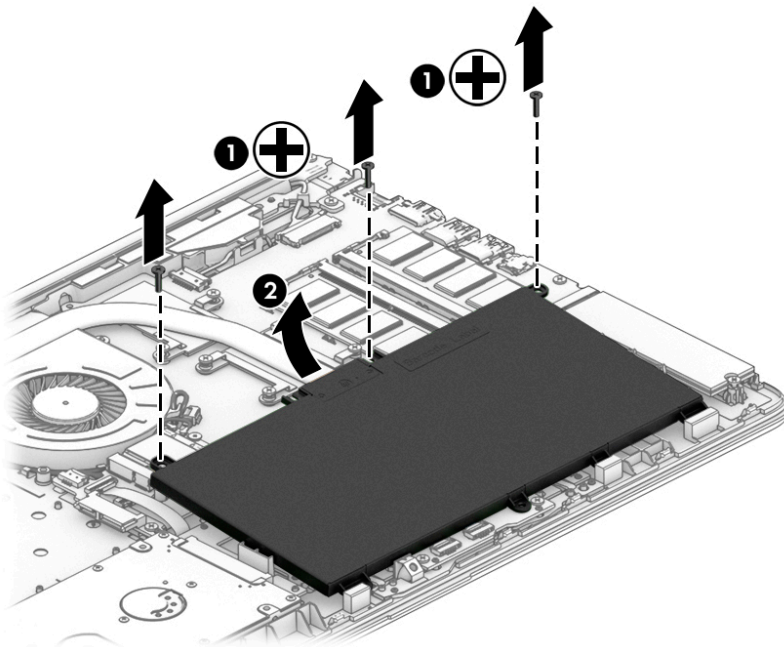

Reverse this procedure to install the battery.

When installing the battery, be sure to install screws in the proper locations. The following image shows the locations around the battery that have holes but do NOT require screws.

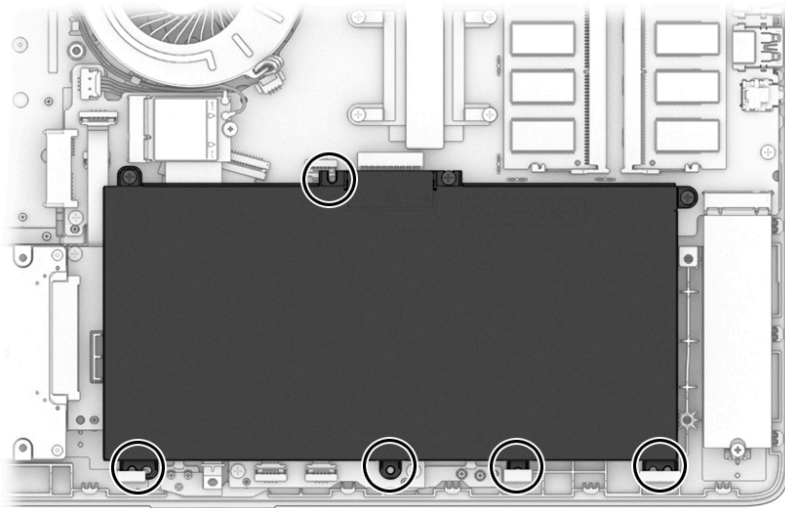

Memory

Description	Spare part number
Memory module, 8 GB	862398-855
Memory module, 4 GB	862397-855

Before removing the memory modules, follow these steps:

1. Prepare the computer for disassembly ([Preparation for disassembly on page 33](#)).
2. Remove the optical drive (see [Optical drive on page 34](#)).
3. Remove the bottom cover (see [Bottom cover on page 38](#)).
4. Remove the battery (see [Battery on page 41](#)).

Remove the memory modules:

1. Spread the two retention clips outward **(1)** until the memory module tilts up at a 45-degree angle.
2. Grasp the edge of the memory module **(2)**, and then gently pull the module out of the slot. Use the same procedure to remove both memory modules.

⚠ CAUTION: To prevent damage to the memory module, hold the memory module by the edges only. Do not touch the components on the memory module.

To protect a memory module after removal, place it in an electrostatic-safe container.

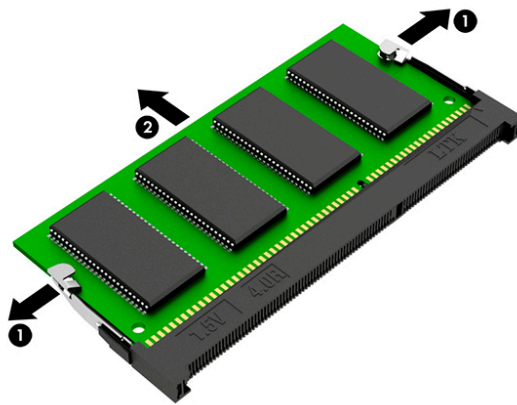

Install the memory modules:

📌 IMPORTANT: To prevent damage to the memory module, hold the memory module by the edges only. Do not touch the components on the memory module. Do not bend the memory module.

1. Align the notched edge of the memory module with the tab in the memory module slot **(1)**.
2. Press the module into the slot until seated **(2)**.

3. Gently press down on the module edges until the side retention clips snap into place **(3)**.

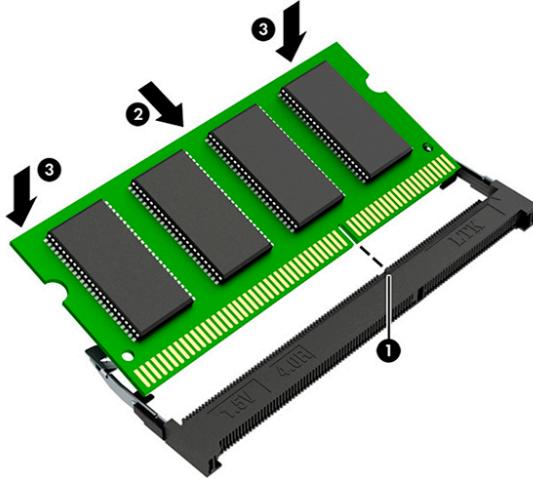

Hard drive

Description	Spare part number
Hard drive, 2 TB, 5400 rpm, 7 mm	912487-855
Hard drive, 1 TB, 5400 rpm, 7 mm	762990-005
Hard drive, 500 GB, 5400 rpm, 7 mm	778186-005
Hard drive bracket	L20455-001

Before removing the hard drive, follow these steps:

1. Prepare the computer for disassembly ([Preparation for disassembly on page 33](#)).
2. Remove the optical drive (see [Optical drive on page 34](#)).
3. Remove the bottom cover (see [Bottom cover on page 38](#)).
4. Remove the battery (see [Battery on page 41](#)).

Remove the hard drive:

1. Slide the hard drive away from the connector **(1)**, and then lift the hard drive out of the computer **(2)**.

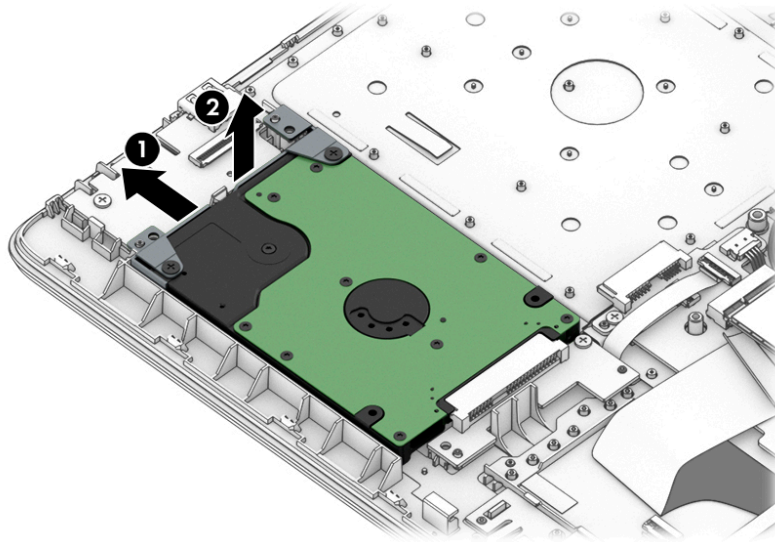

2. If it is necessary to disassemble the hard drive, remove the two Phillips M3.0×3.0 screws (1), and then lift the bracket off the drive (2).

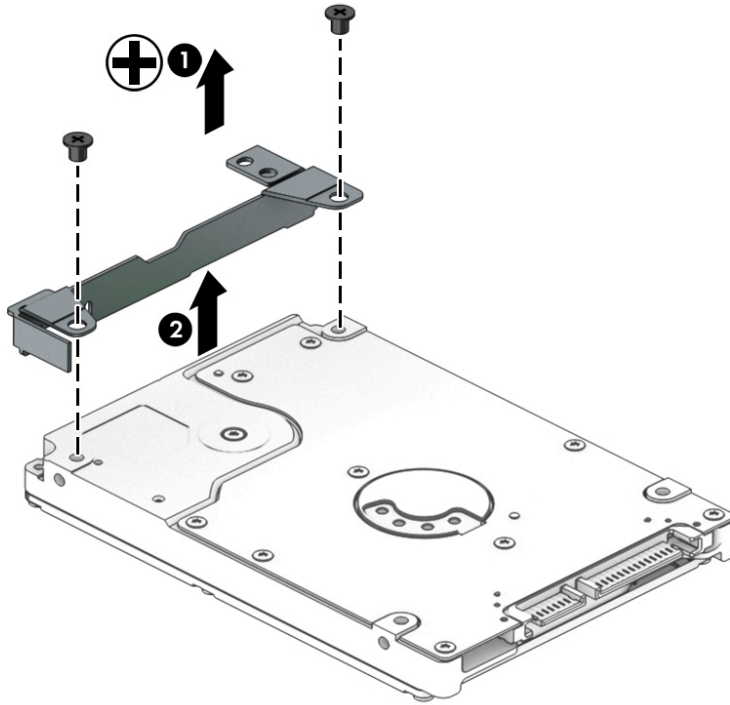

Reverse this procedure to reassemble and install the hard drive.

Solid-state drive

Description	Spare part number
512 GB, PCIe, NVMe	L20385-001
256 GB, PCIe, NVMe	L20384-001
256 GB, SATA-3, TLC	L20382-001
128 GB, SATA-3, TLC	L20381-001

Before removing the solid-state drive, follow these steps:

1. Prepare the computer for disassembly ([Preparation for disassembly on page 33](#)).
2. Remove the optical drive (see [Optical drive on page 34](#)).
3. Remove the bottom cover (see [Bottom cover on page 38](#)).
4. Remove the battery (see [Battery on page 41](#)).

Remove the solid-state drive:

- ▲ Remove the Phillips M2.0×3.0 screw **(1)**, and then pull the solid-state drive module from the socket **(2)**.

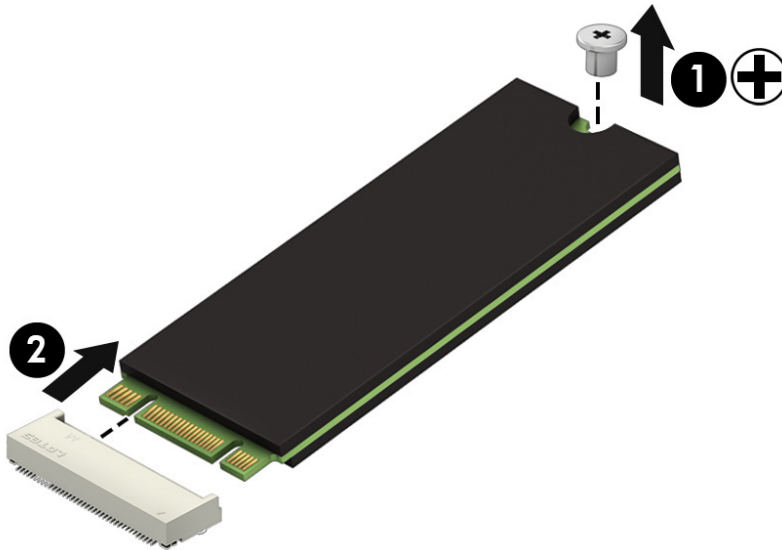

Reverse this procedure to install the solid-state drive.

Solid-state drive bracket and connector board

Description	Spare part number
Solid-state drive bracket	L20458-001
Solid-state drive connector board	L22542-001
Solid-state drive cable	L20456-001

Before removing the solid-state drive bracket and connector board, follow these steps:

1. Prepare the computer for disassembly ([Preparation for disassembly on page 33](#)).
2. Remove the optical drive (see [Optical drive on page 34](#)).
3. Remove the bottom cover (see [Bottom cover on page 38](#)).
4. Remove the battery (see [Battery on page 41](#)).
5. Remove the solid-state drive (see [Solid-state drive on page 47](#)).

Remove the solid-state drive bracket and connector board:

1. Slide the bracket toward the side of the computer **(1)**, and then lift the bracket out of the computer **(2)**.

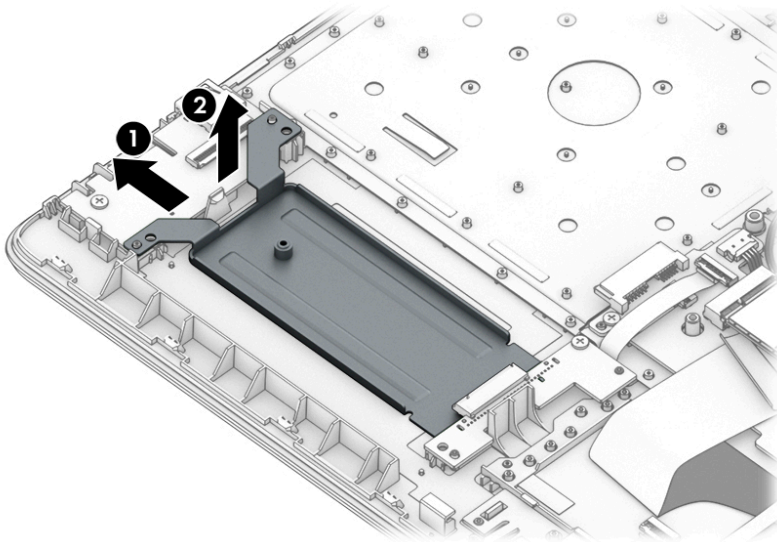

2. Disconnect the solid-state connector board cable from the system board ZIF connector **(1)**.
3. Remove the Phillips M2.0×3.0 screw **(2)** that secures the board to the computer.

4. Remove the connector board from the computer **(3)**.

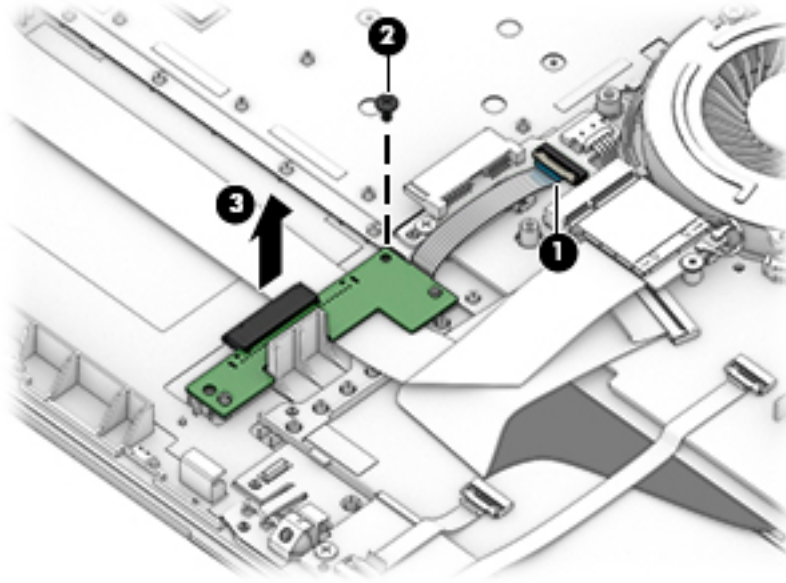

Reverse this procedure to install the solid-state drive bracket and connector board.

Optane memory module

 **IMPORTANT:** The Optane memory module is installed into the M.2 connector that is used by M.2 solid-state drives. You cannot install both an Optane memory module and a solid-state drive in the computer.

Description	Spare part number
Optane memory module, 16 GB	L20383-001

Before removing the Optane memory module, follow these steps:

1. Prepare the computer for disassembly ([Preparation for disassembly on page 33](#)).
2. Remove the optical drive (see [Optical drive on page 34](#)).
3. Remove the bottom cover (see [Bottom cover on page 38](#)).
4. Remove the battery (see [Battery on page 41](#)).

Remove the Optane memory module:

- ▲ Remove the Phillips M2.0×3.0 screw **(1)**, and then pull the solid-state drive module from the socket **(2)**.

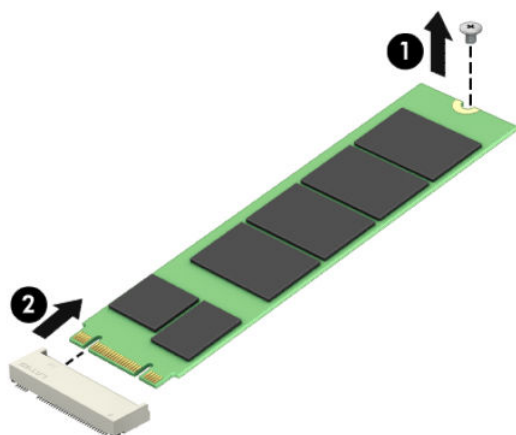

Reverse this procedure to install the Optane memory module.

WLAN module

Description	Spare part number
Intel Dual band wireless-AC 3168 802.11AC 1×1 WiFi + Bluetooth 4.2 Combo Adapter (non-vPro)	863934-855
Realtek RTL8822BE 802.11 ac 2×2 WiFi + Bluetooth 4.2 Combo Adapter (MU-MIMO supported)	924813-855
Realtek RTL8821CE 802.11 ac 1×1 WiFi + Bluetooth 4.2 Combo Adapter (MU-MIMO supported)	L17365-005
Realtek RTL8723DE 802.11 bgn 1×1 WiFi + Bluetooth 4.2 Combo Adapter	L21480-005

Before removing the WLAN module, follow these steps:

1. Prepare the computer for disassembly ([Preparation for disassembly on page 33](#)).
2. Remove the optical drive (see [Optical drive on page 34](#)).
3. Remove the bottom cover (see [Bottom cover on page 38](#)).
4. Remove the battery (see [Battery on page 41](#)).

Remove the WLAN module:

1. Disconnect the two antenna cables from the module (**1**).
2. Remove the Phillips M2.0×3.0 screw (**2**), and then pull the module out of the socket (**3**).

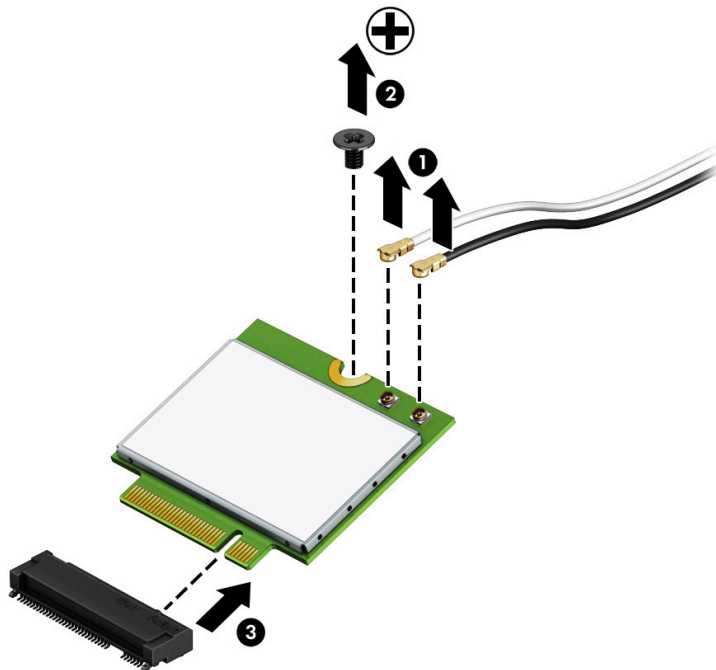

Reverse this procedure to install the WLAN module.

Hard drive connector board

Description	Spare part number
Hard drive connector board	L20454-001

Before removing the hard drive connector board, follow these steps:

1. Prepare the computer for disassembly ([Preparation for disassembly on page 33](#)).
2. Remove the optical drive (see [Optical drive on page 34](#)).
3. Remove the bottom cover (see [Bottom cover on page 38](#)).
4. Remove the battery (see [Battery on page 41](#)).
5. Remove the hard drive (see [Hard drive on page 45](#)).

Remove the hard drive connector:

1. Disconnect the cable from the system board ZIF connector **(1)**.
2. Remove the Phillips M2.0×3.0 screw **(2)** that secures the board to the computer.
3. Remove the board from the computer **(3)**.

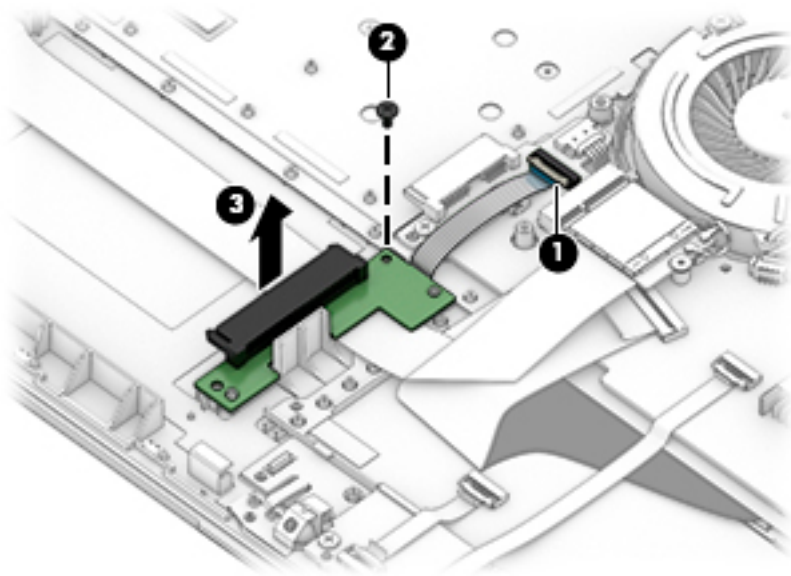

Reverse this procedure to install the hard drive connector board.

USB/card reader board

Description	Spare part number
USB/card reader board	L20448-001
USB/card reader board cable	L20452-001

Before removing the USB/card reader board, follow these steps:

1. Prepare the computer for disassembly ([Preparation for disassembly on page 33](#)).
2. Remove the optical drive (see [Optical drive on page 34](#)).
3. Remove the bottom cover (see [Bottom cover on page 38](#)).
4. Remove the battery (see [Battery on page 41](#)).

Remove the USB/card reader board:

1. Disconnect the cable from the ZIF connector on the USB board **(1)**.
2. Remove the Phillips M2.0×3.0 screw **(2)**, and then remove the board from the computer **(3)**.

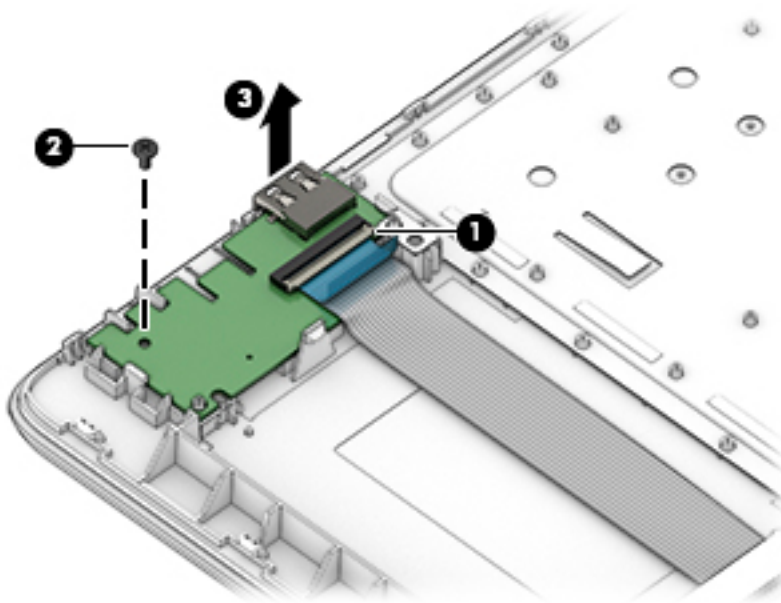

Reverse this procedure to replace the USB/card reader board.

TouchPad button board

Description	Spare part number
TouchPad button board	not spared
TouchPad button board cable	L20451-001

Before removing the TouchPad button board, follow these steps:

1. Prepare the computer for disassembly ([Preparation for disassembly on page 33](#)).
2. Remove the optical drive (see [Optical drive on page 34](#)).
3. Remove the bottom cover (see [Bottom cover on page 38](#)).
4. Remove the battery (see [Battery on page 41](#)).

Remove the TouchPad button board:

1. Disconnect the system board cable from the ZIF connector on the TouchPad button board **(1)**.
2. Disconnect the TouchPad cable from the ZIF connector on the TouchPad button board **(2)**.
3. Remove the two Phillips M2.0×3.0 screws **(3)** that secure the board to the computer.
4. Remove the TouchPad button board from the computer **(4)**.

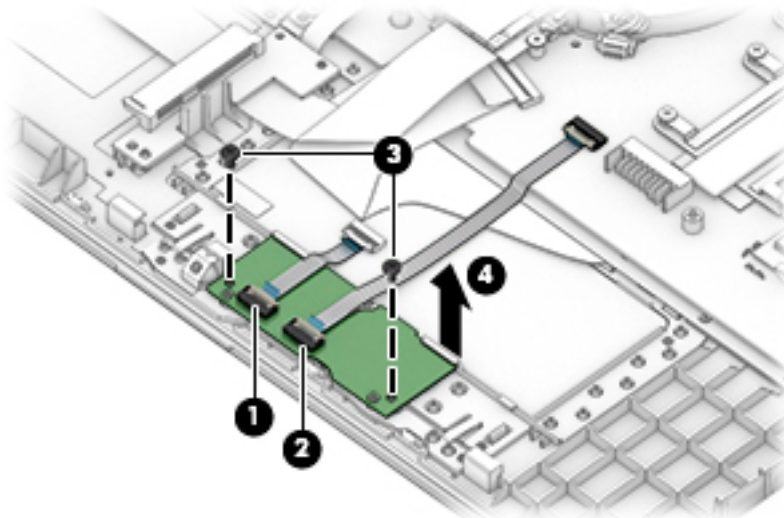

Reverse this procedure to install the TouchPad button board.

TouchPad module

Description	Spare part number
TouchPad module	L20449-001
TouchPad module cable	L20450-001

Before removing the TouchPad module, follow these steps:

1. Prepare the computer for disassembly ([Preparation for disassembly on page 33](#)).
2. Remove the optical drive (see [Optical drive on page 34](#)).
3. Remove the bottom cover (see [Bottom cover on page 38](#)).
4. Remove the battery (see [Battery on page 41](#)).

To remove the TouchPad module:

1. Disconnect the TouchPad cable from the ZIF connector on the TouchPad **(1)** and the TouchPad button board cable from the ZIF connector on the system board **(2)**.

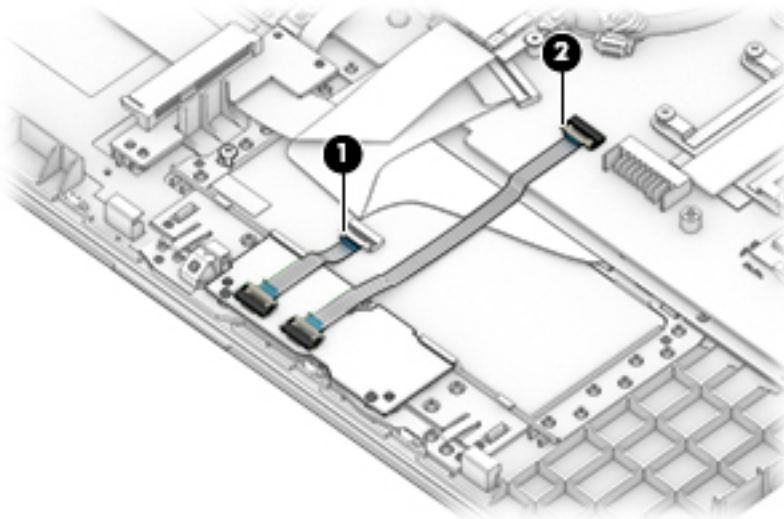

2. Peel the tape off the TouchPad **(1)**.
3. Starting in the corner, use a plastic, non-marking tool to pry up the TouchPad module to disengage the adhesive that secures it to the top cover **(2)**

4. Working around each edge, pry the TouchPad module loose, and then remove it from the computer **(3)**.

 **NOTE:** The TouchPad module may be very tight and difficult to remove.

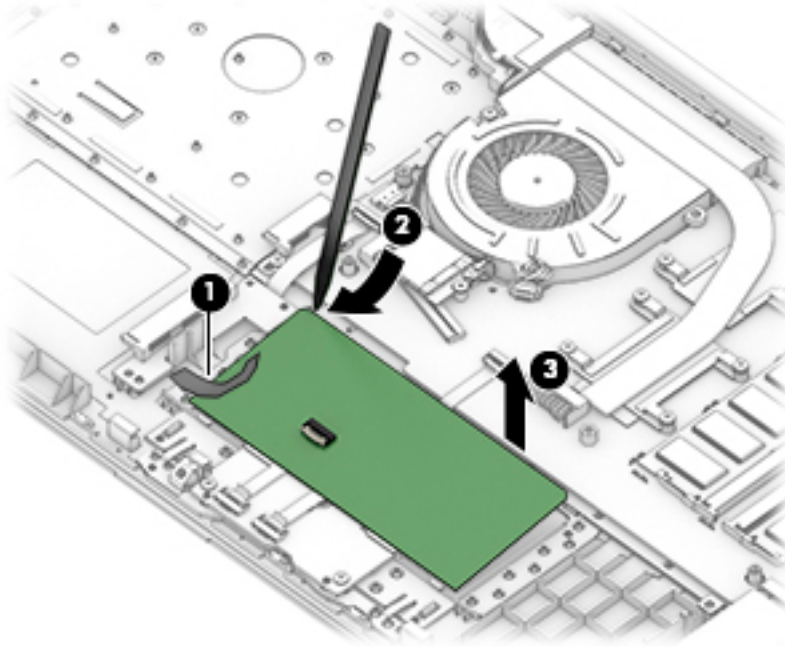

Reverse this procedure to install the TouchPad module.

Fan

Description	Spare part number
Fan for use in models with discrete graphics	L20473-001
Fan for use in models with UMA graphics	L20474-001

Before removing the fan, follow these steps:

1. Prepare the computer for disassembly ([Preparation for disassembly on page 33](#)).
2. Remove the optical drive (see [Optical drive on page 34](#)).
3. Remove the bottom cover (see [Bottom cover on page 38](#)).
4. Remove the battery (see [Battery on page 41](#)).

Remove the fan:

1. Disconnect the fan cable from the system board **(1)**.
2. Remove the Phillips M2.5×6.0 screw **(2)** that secures the fan to the computer.
3. Lift the fan from the computer **(3)**.

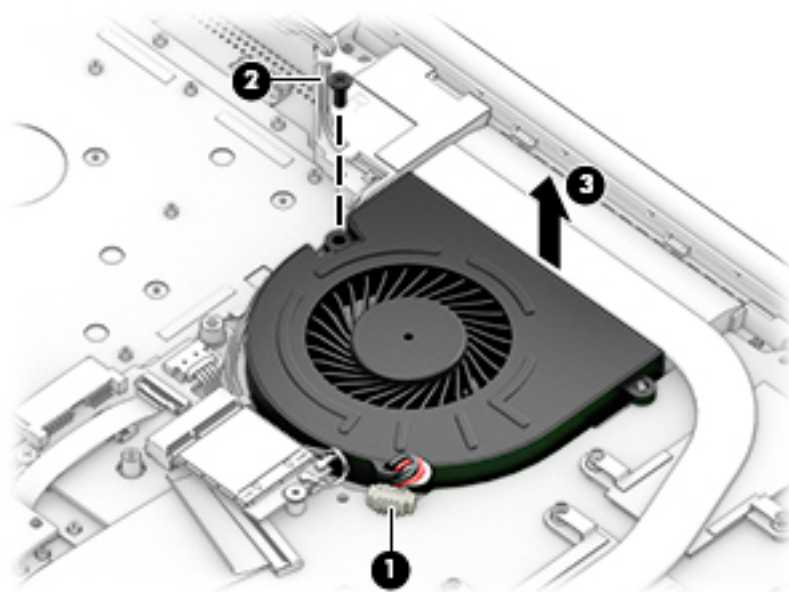

Reverse this procedure to install the fan.

Heat sink assembly

Description	Spare part number
Heat sink for use in models with i7-8550, i5-8250, i3-8130U, i7-7500U, i3-7020U processors and integrated discrete graphics memory	L20469-001
Heat sink for use in models with i7-8550, i5-8250, i3-8130U, i7-7500U, i3-7020U processors and UMA graphics memory	L20470-001
Heat plate for use in fanless models with UMA graphics memory and an Intel Pentium or Celeron processor	L20472-001
Heat sink for use in models with an Intel Pentium or Celeron processor and discrete graphics memory	L20471-001
Heat sink for use in models with i7-8565U, i5-8265U, i3-8145U processors and discrete graphics memory	L36498-001

Before removing the heat sink, follow these steps:

1. Prepare the computer for disassembly ([Preparation for disassembly on page 33](#)).
2. Remove the optical drive (see [Optical drive on page 34](#)).
3. Remove the bottom cover (see [Bottom cover on page 38](#)).
4. Remove the battery (see [Battery on page 41](#)).

To remove the heat sink assembly from products with integrated UMA graphics:

1. In the order indicated on the heat sink assembly, remove the four Phillips M2.0×3.0 screws **(1)** that secure the heat sink to the computer.
2. Lift the heat sink assembly from the computer **(2)**.

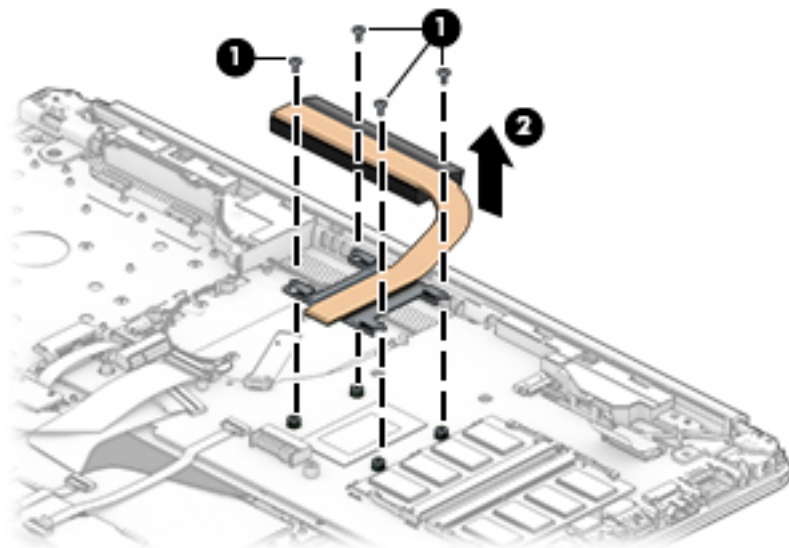

3. Thoroughly clean the thermal material from the surface of the heat sink **(1)** and its associated system board component **(2)** each time the heat sink is removed. Replacement thermal material is included with the heat sink and system board spare part kits.

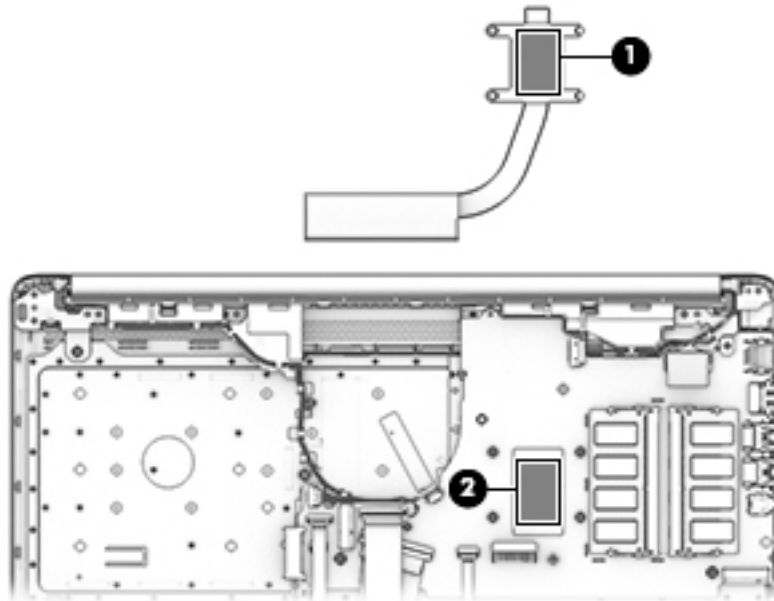

To remove the heat sink assembly from products with discrete graphics:

1. In the order indicated on the heat sink assembly, remove the six Phillips M2.0×3.0 screws **(1)** that secure the heat sink to the computer.
2. Lift the heat sink assembly from the computer **(2)**.

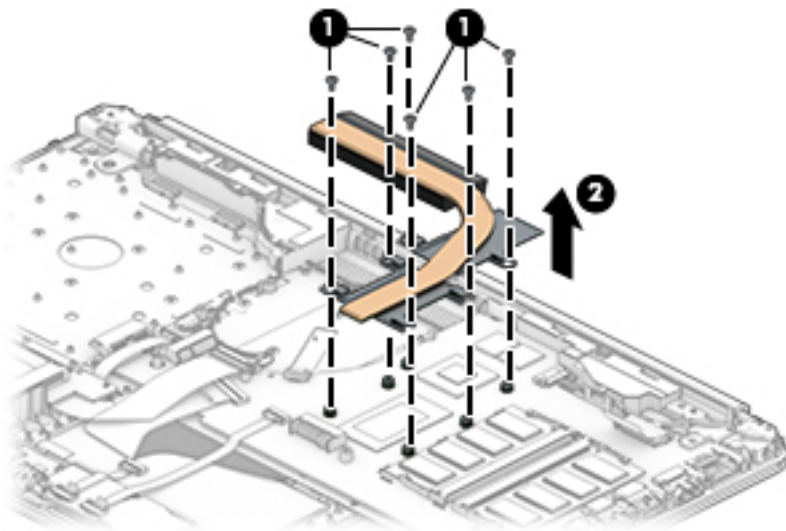

3. Thoroughly clean the thermal material from the surfaces of the heat sink **(1)(3)** and associated system board components **(2)(4)** each time the heat sink is removed. Replacement thermal material is included with the heat sink and system board spare part kits.

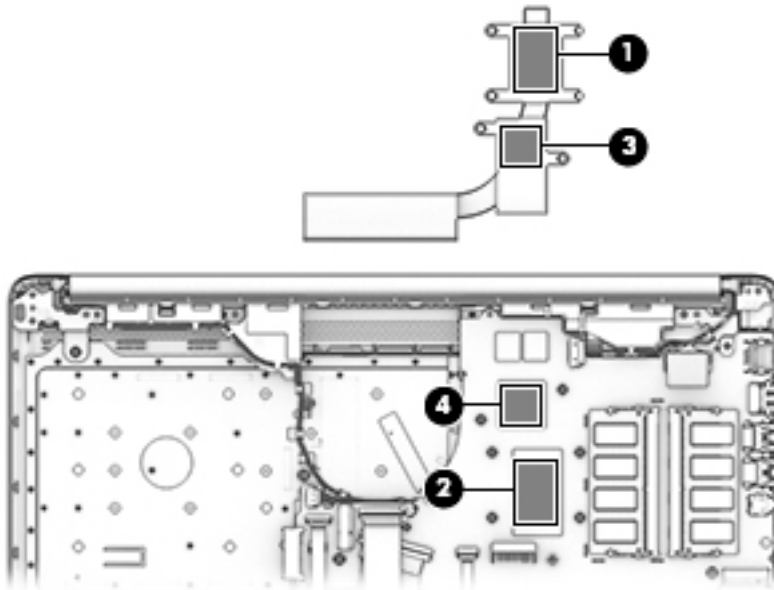

To remove the heat plate from fanless models:

1. In the order indicated on the heat plate, remove the five Phillips M2.0×3.0 screws **(1)** that secure the heat plate to the computer.
2. Lift the heat plate from the computer **(2)**.

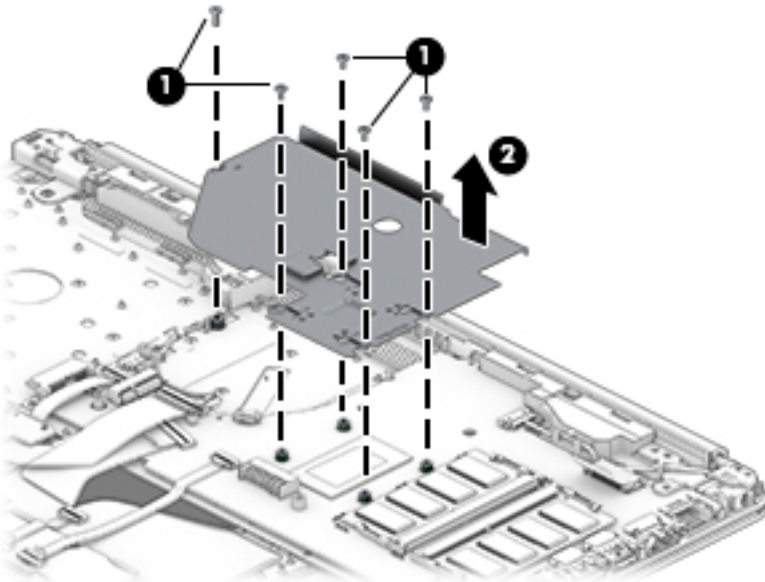

3. Thoroughly clean the thermal material from the surface of the heat plate **(1)** and associated system board component **(2)** each time the heat plate is removed. Replacement thermal material is included with the heat plate and system board spare part kits.

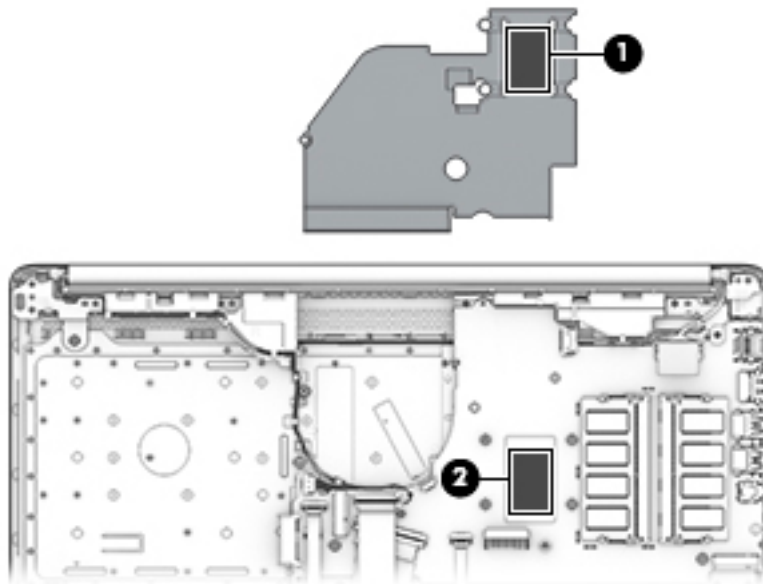

Reverse this procedure to install the heat plate or heat sink assembly.

Display assembly

Full hinge-up displays are not spared. Displays are spared only at the subcomponent level.

Before removing the display panel, follow these steps:

1. Prepare the computer for disassembly ([Preparation for disassembly on page 33](#)).
2. Remove the optical drive (see [Optical drive on page 34](#)).
3. Remove the bottom cover (see [Bottom cover on page 38](#)).
4. Remove the battery (see [Battery on page 41](#)).

Remove the display assembly:

1. Lift the tape from the display connector on the system board **(1)**.
2. Disconnect the cable from the connector **(2)**.
3. Remove the cable from the clip **(3)**.

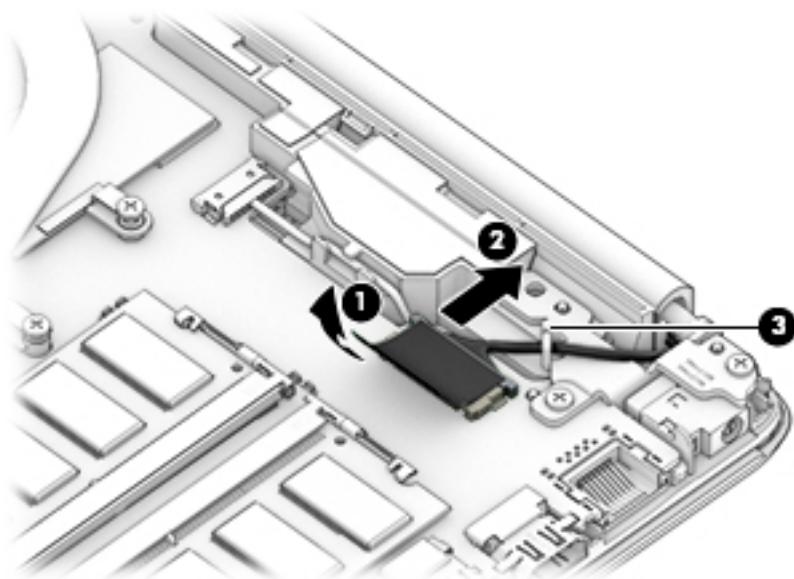

4. Remove the four Phillips M2.5×6.0 screws **(1)** from the display hinges.
5. Remove the Phillips broad head M2.0×2.0 screw **(2)** from the right display hinge.
6. Rotate the hinges upward **(3)**.

7. Separate the display from the computer **(4)**.

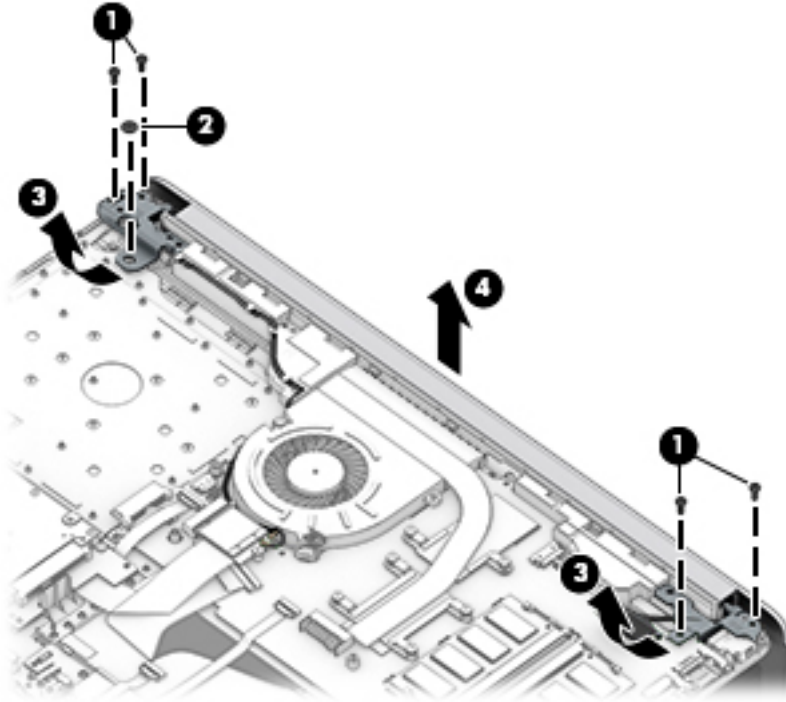

Remove the display assembly subcomponents:

1. To remove the hinge cover, pull upward near the hinge to disengage it from the display enclosure **(1)**, and then remove the hinge cover from the display enclosure **(2)**.

Hinge covers are available using the following spare part numbers:

- L20423-001: Jet black
- L20427-001: Sparkling black
- L20424-001: Natural silver
- L20425-001: Pale gold
- L20430-001: Scarlet red
- L20426-001: Twilight blue
- L20428-001: Smoke gray
- L20422-001: Snow white (full-featured models)
- L21306-001: Snow white (defeatured models)
- L20431-001: Maroon burgundy
- L28516-001: Iridescent pale rose gold
- L28517-001: Iridescent ceramic white
- L31729-001: Ocean teal
- L31730-001: Real tree

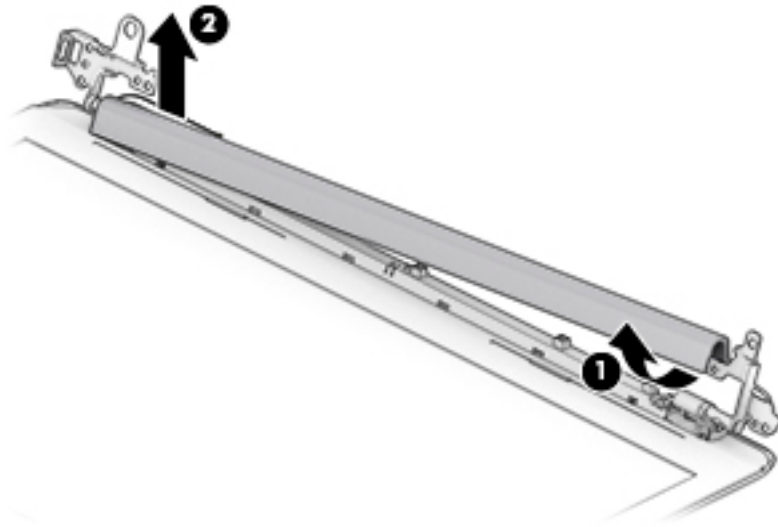

When replacing the hinge cover, make sure the hinges rotate downward as far as they can go. Align the cover, and then start from above and rotate the cover downward onto the hinges. Make sure the clips snap into place along the bottom of the display cover.

2. If it is necessary to replace the display bezel:
 - a. Remove the two Phillips M2.0×3.0 screws (1), flex the top (2) of the bezel, the inside edges of the left and right sides (3), and then the bottom (4) of the bezel until it disengages from the display enclosure.
 - b. Remove the bezel (5).

The display bezel is available using spare part number L20421-001 or L32367-001 for real tree models.

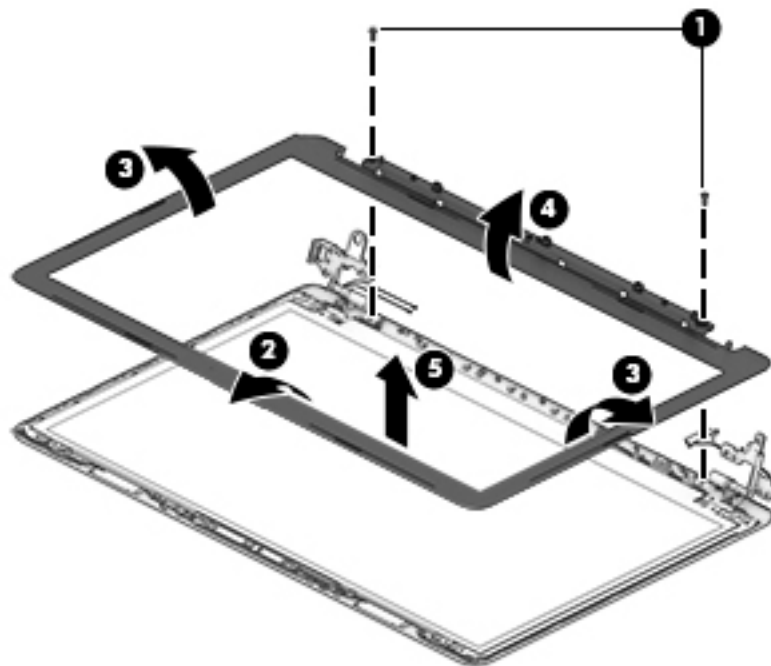

3. If it is necessary to replace the camera/microphone module:

- a. Detach the module **(1)** from the display back cover. (The module is attached with double-sided adhesive.)
- b. Disconnect the cable **(2)** from the camera/microphone module.

The HD camera module is available using spare part number L20447-001. The VGA camera module is available using spare part number L20446-001.

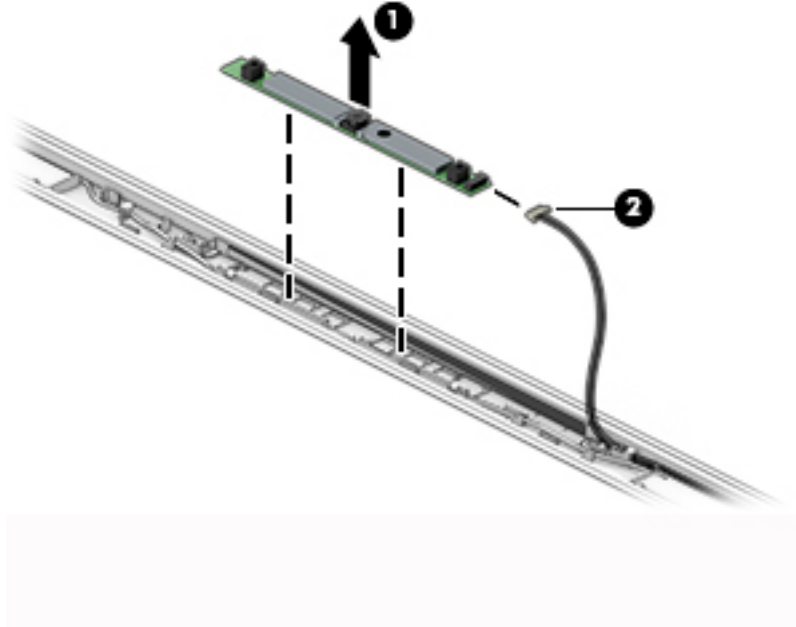

4. If it is necessary to replace the display panel:

 **IMPORTANT:** HD panels are secured to the display enclosure with screws. FHD panels are secured with tape.

- a. **HD panels:**

Remove the four Phillips M2.0×3.0 screws that secure the panel to the display enclosure.

Remove the four Phillips M2.0×3.0 screws that secure the panel to the display enclosure.

Remove the four Phillips M2.0×3.0 screws that secure the panel to the display enclosure **(2)**.

Remove the four Phillips M2.0×3.0 screws that secure the panel to the display enclosure.

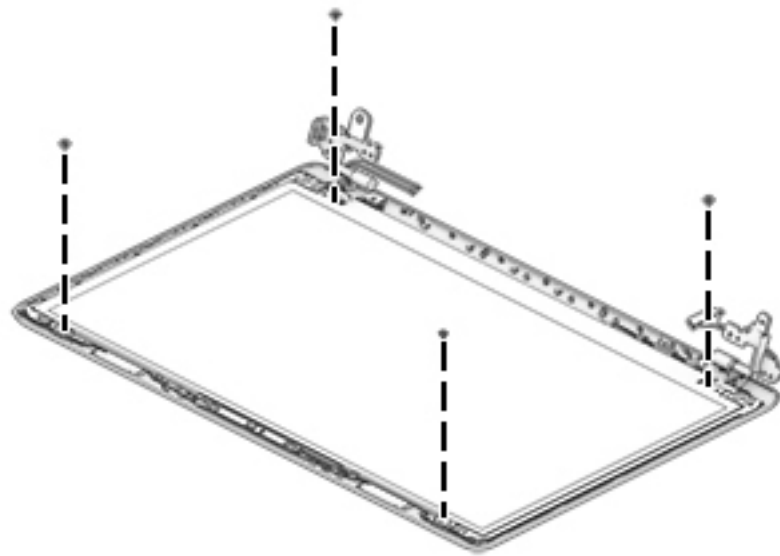

FHD panels:

- b. Pull the tape out from behind the left and right sides of the panel.



NOTE: You have to pull on the tape multiple times before it is completely removed.

Display panel stretchable adhesive tape is available using spare part number L29080-001.

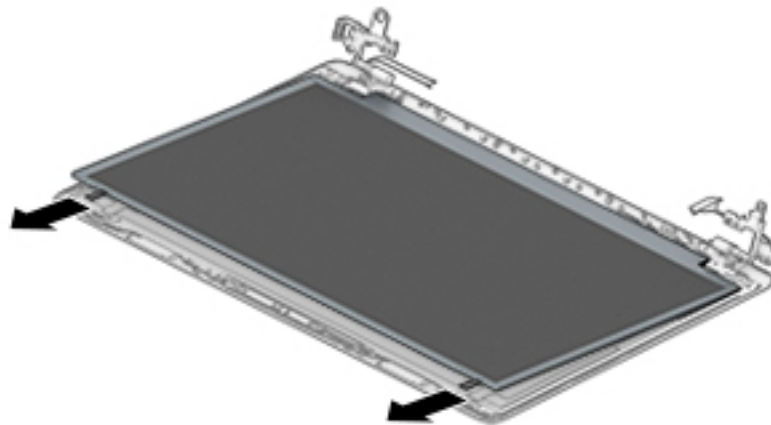

- c. **HD and FHD panels:**

Swing the top edge of the display panel forward and position it upside down next to the display enclosure **(1)**.

- d. Release the adhesive support strip **(2)** that secures the display panel cable connector to the display panel.

- e. Disconnect the display panel cable **(3)** from the display panel.

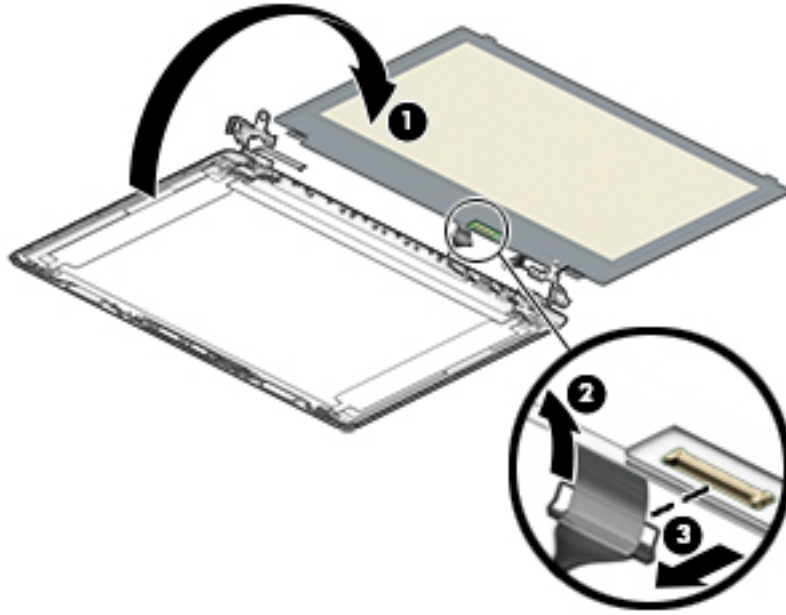

- f. Remove the display panel.

Raw display panels are available using the following spare part numbers:

L23208-001: FHD, anti glare

L23209-001: FHD, BrightView

L23210-001: HD, anti glare

L23211-001: HD, BrightView

- 5. If it is necessary to replace the display hinges:

- a. Remove the three Phillips M2.5×2.5 screws **(1)** from each hinge.

- b. Remove the display hinges (2).

The display hinges are available using spare part number L20420-001.

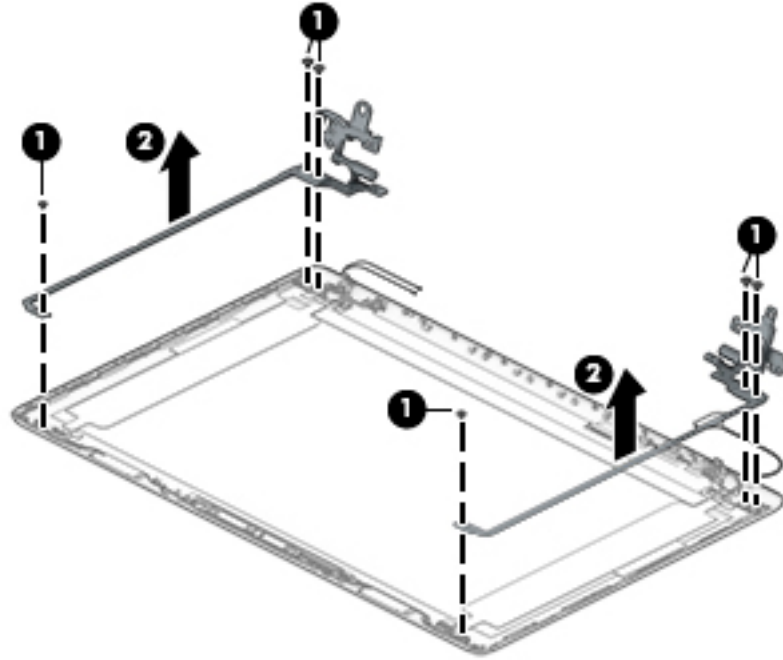

6. If it is necessary to replace the display panel cable:

- a. Release the cable from the retention clips and routing channel built into the bottom edge and side of the display enclosure (1).
- b. Remove the display panel cable (2).

The display panel cable is available using the following spare part numbers:

L20443-001: HD, non-touch display

L23064-001: FHD, non-touch display

L20442-001: HD, touch display

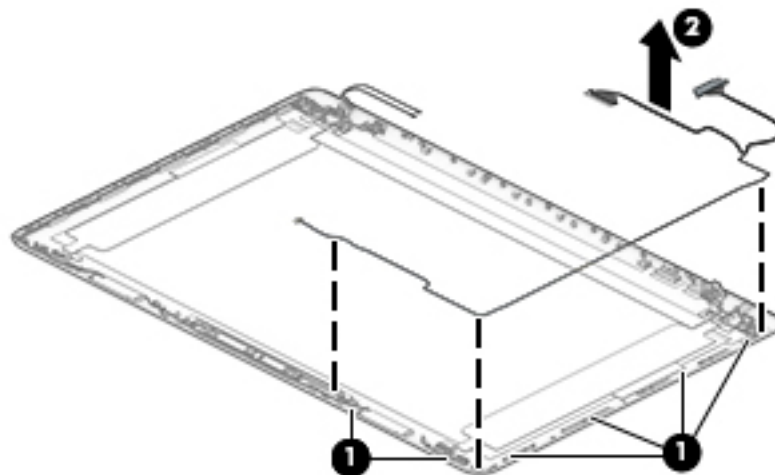

7. If it is necessary to replace the wireless antenna cables and transceivers:

- a. Remove the antennas from the top of the display enclosure **(1)**.
- b. Release the wireless antenna cables from the retention clips and routing channel built into the sides of the display enclosure **(2)**.

Antennas are available using the following spare part numbers:

L20445-001: Single antenna models

L23060-001: Single antenna, narrow bezel models

L20444-001: Dual antenna models

L23059-001: Dual antenna, narrow bezel models

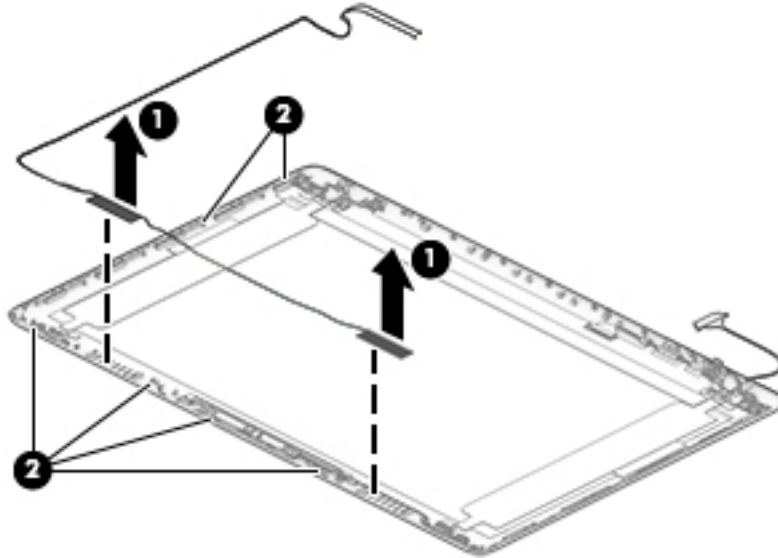

Use the following image to determine proper cable routing in the display of the antenna cable **(1)** and display cable **(2)**.

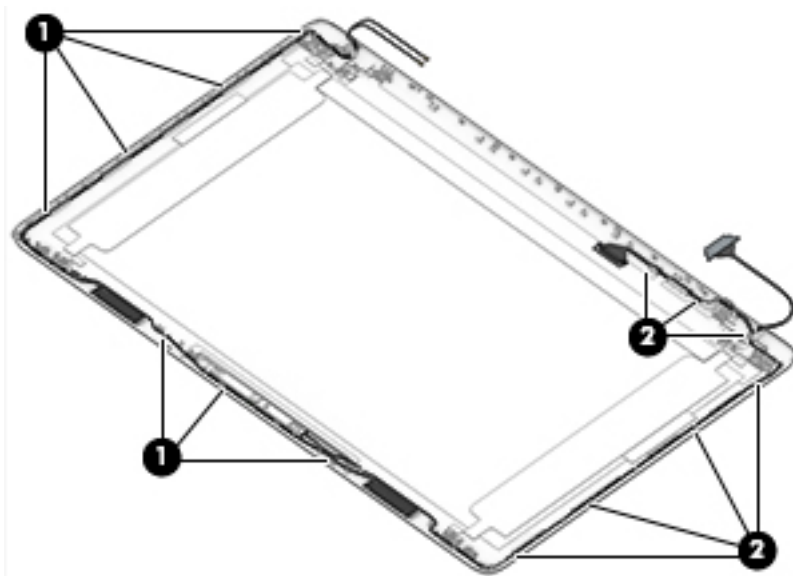

The display rear cover is available using the following spare part numbers:

L20433-001: Jet black

L23061-001: Jet black (narrow bezel models)

L20437-001: Sparkling black

L20434-001: Natural silver

L23062-001: Natural silver (narrow bezel models)

L20435-001: Pale gold

L20440-001: Scarlet red

L20436-001: Twilight blue

L20438-001: Smoke gray

L23063-001: Smoke gray (narrow bezel models)

L20432-001: Snow white (full-featured models)

L21307-001: Snow white (defeatured models)

L20441-001: Maroon burgundy

L28509-001: Iridescent ceramic white

L28508-001: Iridescent pale rose gold

L31723-001: Ocean teal

L31724-001: Real tree

Reverse these procedures to reassemble and install the display assembly components.

When reassembling an FHD display assembly, be sure to install the following parts into the display enclosure from the Display Miscellaneous Kit, spare part number L23065-001 and display panel stretchable adhesive tape, spare part number L29080-001.

(1): Four positioning corner pieces

(2): Two gaskets

(3): Display panel stretchable adhesive tape

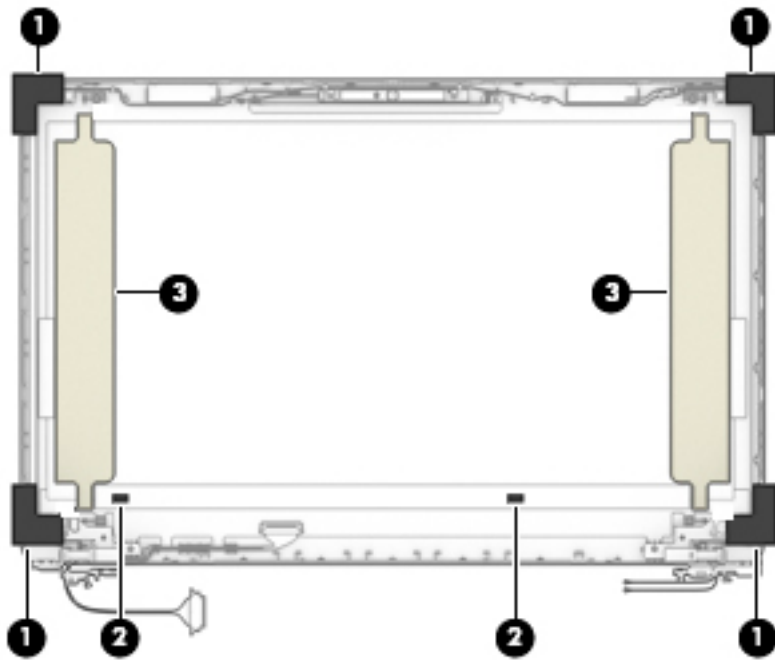

System board



NOTE: All system board spare part kits include replacement thermal material.

All system boards use the following part numbers:

xxxxxx-001: Non-Windows operating systems

xxxxxx-601: Windows operating system

Description	Spare part number
System board for use in models with discrete graphics memory:	
• Intel Core i7-8565U processor with 4 GB of discrete graphics memory	L35243-xx1
• Intel Core i7-8565U processor with 2 GB of discrete graphics memory	L35241-xx1
• Intel Core i7-8550U processor with 4 GB of discrete graphics memory	L20368-xx1
• Intel Core i7-8550U processor with 2 GB of discrete graphics memory	L20364-xx1
• Intel Core i5-8265U processor with 4 GB of discrete graphics memory	L35242-xx1
• Intel Core i5-8265U processor with 2 GB of discrete graphics memory	L35240-xx1
• Intel Core i5-8250U processor with 2 GB of discrete graphics memory	L20367-xx1
• Intel Core i5-8250U processor with 2 GB of discrete graphics memory	L20362-xx1
• Intel Core i7-7500U processor with 2 GB of discrete graphics memory	L20363-xx1
• Intel Core i5-7200U processor with 2 GB of discrete graphics memory	L36493-xx1
• Intel Core i3-7100U processor with 2 GB of discrete graphics memory	L36492-xx1
• Intel Core i3-7020U processor with 2 GB of discrete graphics memory	L20365-xx1
• Intel Pentium N5000 processor with 2 GB of discrete graphics memory	L20366-xx1
System board for use in models with UMA graphics memory:	
• Intel Core i7-8550U processor	L20371-xx1
• Intel Core i5-8265U processor	L35245-xx1
• Intel Core i5-8250U processor	L20369-xx1
• Intel Core i3-8145U processor	L35244-xx1
• Intel Core i3-8130U processor	L20374-xx1
• Intel Core i7-7500U processor	L20370-xx1
• Intel Core i5-7200U processor	L36494-xx1
• Intel Core i3-7100U processor	L35239-xx1
• Intel Core i3-7020U processor	L20373-xx1
• Intel Pentium N5000 processor	L20375-xx1
• Intel Celeron N4000 processor	L20372-xx1

Before removing the system board, follow these steps:

1. Prepare the computer for disassembly ([Preparation for disassembly on page 33](#)).
2. Remove the following components:
 - a. Optical drive (see [Optical drive on page 34](#))
 - b. Bottom cover (see [Bottom cover on page 38](#))
 - c. Battery (see [Battery on page 41](#))
 - d. Display (see [Display assembly on page 62](#))

When replacing the system board, be sure to remove the following components (as applicable) from the defective system board and install them on the replacement system board:

- WLAN module (see [WLAN module on page 51](#))
- Memory modules (see [Memory on page 43](#))
- Heat sink (see [Heat sink assembly on page 58](#))

Remove the system board:



IMPORTANT: Make special note of each screw size and location during removal and replacement

1. Disconnect the following cables from the system board:
 - (1): Keyboard backlight cable
 - (2): Hard drive connector cable
 - (3): Speaker cable
 - (4): USB/card reader board cable
 - (5): Keyboard cable
 - (6): TouchPad button board cable
 - (7): Power connector cable

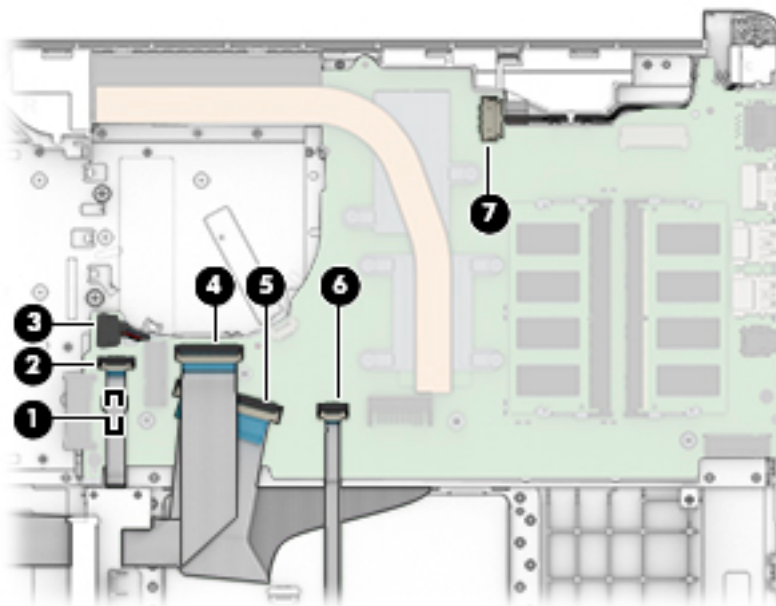

2. Remove the two Phillips M2.0×3.0 screws that secure the system board to the computer (1).

3. Lift the left side of the system board, and then remove the system board from the computer (2).

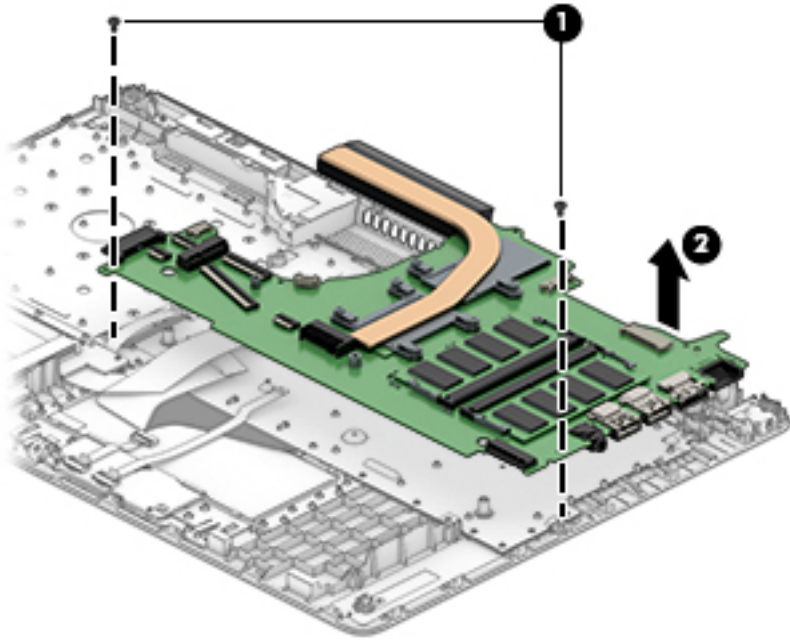

Reverse this procedure to install the system board.

Speakers

Description	Spare part number
Speaker Kit	L20453-001

Before removing the speakers, follow these steps:

1. Prepare the computer for disassembly ([Preparation for disassembly on page 33](#)).
2. Remove the optical drive (see [Optical drive on page 34](#)).
3. Remove the bottom cover (see [Bottom cover on page 38](#)).
4. Remove the battery (see [Battery on page 41](#)).
5. Remove the display (see [Display assembly on page 62](#)).

Remove the speakers:

1. Remove the speaker cable from the clips built into the computer **(1)**.
2. Remove the speakers from the computer **(2)**.

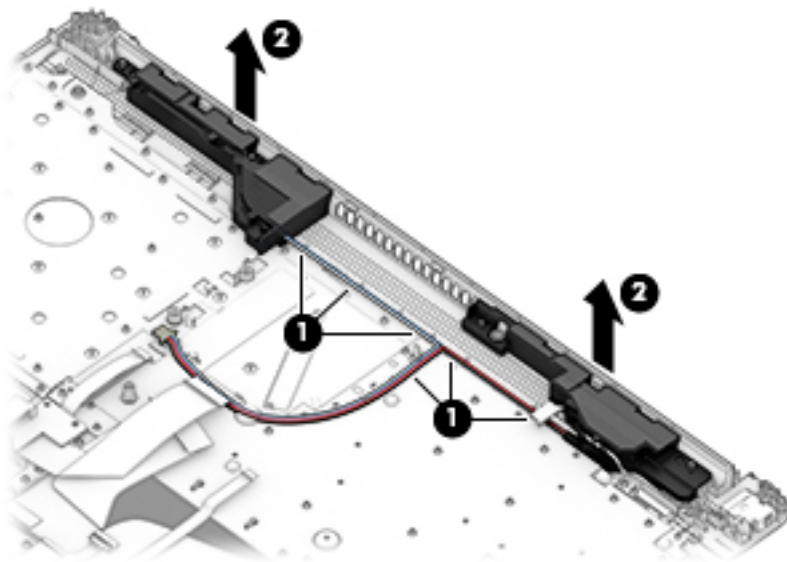

Reverse this procedure to install the speakers.

Power connector cable (DC-in)

Description	Spare part number
Power connector cable	L20475-001
	L09552-001

Before removing the power connector cable, follow these steps:

1. Prepare the computer for disassembly ([Preparation for disassembly on page 33](#)).
2. Remove the optical drive (see [Optical drive on page 34](#)).
3. Remove the bottom cover (see [Bottom cover on page 38](#)).
4. Remove the battery (see [Battery on page 41](#)).
5. Remove the system board (see [System board on page 72](#)).
6. Remove the display (see [Display assembly on page 62](#)).

Remove the power connector cable:

1. Remove the cable from the clips built into the computer **(1)**.
2. Remove the power connector cable from the computer **(2)**.

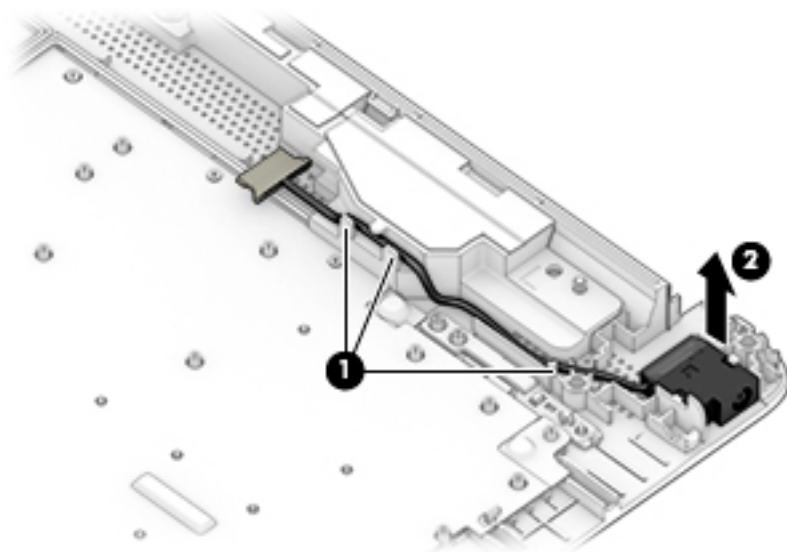

Reverse this procedure to install the power connector cable.

Top cover with keyboard

The top cover with keyboard remains after removing all other spared parts from the computer.

In this section, the first table provides the main spare part number for the keyboards. The second table provides the country codes.

Description	Spare part number
Keyboard, no backlight, jet black	L20387-xx1
Keyboard, no backlight, full-featured models, snow white	L20388-xx1
Keyboard, no backlight, defeatured models, snow white	L23066-xx1
Keyboard, no backlight, ash silver	L20386-xx1
Keyboard, backlit, ash silver (available only with -001 United States, -002 India, and -DB1 Canadian French keyboards)	L23074-xx1
Keyboard, no backlight, iridescent pale rose gold (available only with -001 United States keyboards)	L28504-001
Keyboard, backlit, iridescent pale rose gold (available only with -001 United States keyboards)	L28505-001
Keyboard, no backlight, iridescent ceramic white (available only with -001 United States keyboards)	L28506-001
Keyboard, backlit, iridescent ceramic white (available only with -001 United States keyboards)	L28507-001

For use in country or region	Spare part number	For use in country or region	Spare part number	For use in country or region	Spare part number
Belgium	-A41	Israel	-BB1	Slovenia	-BA1
Bulgaria	-261	Italy	-061	South Korea	-AD1
Canada	-DB1	Japan	-291	Spain	-071
Czech Republic and Slovakia	-FL1	Latin America	-161	Switzerland	-BG1
Denmark, Finland, and Norway	-DH1	The Netherlands	-B31	Taiwan	-AB1
France	-051	Portugal	-131	Thailand	-281
Germany	-041	Romania	-271	Turkey	-141
Greece	-151	Russia	-251	United Kingdom	-031
Hungary	-211	Saudi Arabia	-171	United States	-001
India	-002				

7 Using Setup Utility (BIOS)

Setup Utility, or Basic Input/Output System (BIOS), controls communication between all the input and output devices on the system (such as disk drives, display, keyboard, mouse, and printer). Setup Utility (BIOS) includes settings for the types of devices installed, the startup sequence of the computer, and the amount of system and extended memory.

 **NOTE:** To start Setup Utility on convertible computers, your computer must be in notebook mode and you must use the keyboard attached to your notebook.

Starting Setup Utility (BIOS)

 **CAUTION:** Use extreme care when making changes in Setup Utility (BIOS). Errors can prevent the computer from operating properly.

- ▲ Turn on or restart the computer, quickly press `esc`, and then press `f10`.

Updating Setup Utility (BIOS)

Updated versions of Setup Utility (BIOS) may be available on the HP website.

Most BIOS updates on the HP website are packaged in compressed files called *SoftPaqs*.

Some download packages contain a file named `Readme.txt`, which contains information regarding installing and troubleshooting the file.

Determining the BIOS version

To decide whether you need to update Setup Utility (BIOS), first determine the BIOS version on your computer.

To reveal the BIOS version information (also known as *ROM date* and *System BIOS*), use one of these options.

- HP Support Assistant
 1. Type `support` in the taskbar search box, and then select the **HP Support Assistant** app.
– or –
Select the question mark icon in the taskbar.
 2. Select **My notebook**, and then select **Specifications**.
- Setup Utility (BIOS)
 1. Start Setup Utility (BIOS) (see [Starting Setup Utility \(BIOS\) on page 78](#)).
 2. Select **Main**, and then make note of the BIOS version.
 3. Select **Exit**, select one of the options, and then follow the on-screen instructions.

To check for later BIOS versions, see [Downloading a BIOS update on page 79](#).

Downloading a BIOS update

 **CAUTION:** To reduce the risk of damage to the computer or an unsuccessful installation, download and install a BIOS update only when the computer is connected to reliable external power using the AC adapter. Do not download or install a BIOS update while the computer is running on battery power, docked in an optional docking device, or connected to an optional power source. During the download and installation, follow these instructions:

- Do not disconnect power from the computer by unplugging the power cord from the AC outlet.
- Do not shut down the computer or initiate Sleep.
- Do not insert, remove, connect, or disconnect any device, cable, or cord.

 **NOTE:** If your computer is connected to a network, consult the network administrator before installing any software updates, especially system BIOS updates.

1. Type `support` in the taskbar search box, and then select the **HP Support Assistant** app.
– or –
Select the question mark icon in the taskbar.
2. Select **Updates**, and then select **Check for updates and messages**.
3. Follow the on-screen instructions.
4. At the download area, follow these steps:
 - a. Identify the most recent BIOS update and compare it to the BIOS version currently installed on your computer. If the update is more recent than your BIOS version, make a note of the date, name, or other identifier. You may need this information to locate the update later, after it has been downloaded to your hard drive.
 - b. Follow the on-screen instructions to download your selection to the hard drive.

Make a note of the path to the location on your hard drive where the BIOS update is downloaded. You will need to access this path when you are ready to install the update.

BIOS installation procedures vary. Follow any instructions that appear on the screen after the download is complete. If no instructions appear, follow these steps:

1. Type `file` in the taskbar search box, and then select **File Explorer**.
2. Select your hard drive designation. The hard drive designation is typically Local Disk (C:).
3. Using the hard drive path you recorded earlier, open the folder that contains the update.
4. Double-click the file that has an `.exe` extension (for example, `filename.exe`).

The BIOS installation begins.
5. Complete the installation by following the on-screen instructions.

 **NOTE:** After a message on the screen reports a successful installation, you can delete the downloaded file from your hard drive.

8 Using HP PC Hardware Diagnostics

Using HP PC Hardware Diagnostics Windows (select products only)

HP PC Hardware Diagnostics Windows is a Windows-based utility that allows you to run diagnostic tests to determine whether the computer hardware is functioning properly. The tool runs within the Windows operating system in order to diagnose hardware failures.

If HP PC Hardware Diagnostics Windows is not installed on your computer, first you must download and install it. To download HP PC Hardware Diagnostics Windows, see [Downloading HP PC Hardware Diagnostics Windows on page 80](#).

After HP PC Hardware Diagnostics Windows is installed, follow these steps to access it from HP Help and Support or HP Support Assistant.

1. To access HP PC Hardware Diagnostics Windows from HP Help and Support:
 - a. Select the **Start** button, and then select **HP Help and Support**.
 - b. Right-click **HP PC Hardware Diagnostics Windows**, select **More**, and then select **Run as administrator**.

– or –

To access HP PC Hardware Diagnostics Windows from HP Support Assistant:

- a. Type `support` in the taskbar search box, and then select the **HP Support Assistant** app.
 - or –
 - Select the question mark icon in the taskbar.
 - b. Select **Troubleshooting and fixes**.
 - c. Select **Diagnostics**, and then select **HP PC Hardware Diagnostics Windows**.
2. When the tool opens, select the type of diagnostic test you want to run, and then follow the on-screen instructions.



NOTE: If you need to stop a diagnostic test at any time, select **Cancel**.

3. When HP PC Hardware Diagnostics Windows detects a failure that requires hardware replacement, a 24-digit Failure ID code is generated. For assistance in correcting the problem, contact support, and then provide the Failure ID code.

Downloading HP PC Hardware Diagnostics Windows

- The HP PC Hardware Diagnostics Windows download instructions are provided in English only.
- You must use a Windows computer to download this tool because only .exe files are provided.

Downloading the latest HP PC Hardware Diagnostics Windows version

To download HP PC Hardware Diagnostics Windows, follow these steps:

1. Go to <http://www.hp.com/go/techcenter/pcdiags>. The HP PC Diagnostics home page is displayed.
2. In the **HP PC Hardware Diagnostics** section, select **Download**, and then select a location on your computer or a USB flash drive.

The tool is downloaded to the selected location.

Downloading HP Hardware Diagnostics Windows by product name or number (select products only)

 **NOTE:** For some products, it may be necessary to download the software to a USB flash drive by using the product name or number.

To download HP PC Hardware Diagnostics Windows by product name or number, follow these steps:

1. Go to <http://www.hp.com/support>.
2. Select **Get software and drivers**, select your type of product, and then enter the product name or number in the search box that is displayed.
3. In the **HP PC Hardware Diagnostics** section, select **Download**, and then select a location on your computer or a USB flash drive.

The tool is downloaded to the selected location.

Installing HP PC Hardware Diagnostics Windows

To install HP PC Hardware Diagnostics Windows, follow these steps:

- ▲ Navigate to the folder on your computer or the USB flash drive where the .exe file was downloaded, double-click the .exe file, and then follow the on-screen instructions.

Using HP PC Hardware Diagnostics UEFI

 **NOTE:** For Windows 10 S computers, you must use a Windows computer and a USB flash drive to download and create the HP UEFI support environment because only .exe files are provided. For more information, see [Downloading HP PC Hardware Diagnostics UEFI to a USB flash drive on page 82](#).

HP PC Hardware Diagnostics UEFI (Unified Extensible Firmware Interface) allows you to run diagnostic tests to determine whether the computer hardware is functioning properly. The tool runs outside the operating system so that it can isolate hardware failures from issues that are caused by the operating system or other software components.

If your PC will not boot into Windows, you can use HP PC Hardware Diagnostics UEFI to diagnose hardware issues.

When HP PC Hardware Diagnostics UEFI detects a failure that requires hardware replacement, a 24-digit Failure ID code is generated. For assistance in correcting the problem, contact support, and provide the Failure ID code.

 **NOTE:** To start diagnostics on a convertible computer, your computer must be in notebook mode, and you must use the attached keyboard.

 **NOTE:** If you need to stop a diagnostic test, press **esc**.

Starting HP PC Hardware Diagnostics UEFI

To start HP PC Hardware Diagnostics UEFI, follow these steps:

1. Turn on or restart the computer, and quickly press *esc*.
2. Press *f2*.

The BIOS searches three places for the diagnostic tools, in the following order:

- a. Connected USB flash drive



NOTE: To download the HP PC Hardware Diagnostics UEFI tool to a USB flash drive, see [Downloading the latest HP PC Hardware Diagnostics UEFI version on page 82](#).

- b. Hard drive

- c. BIOS

3. When the diagnostic tool opens, select a language, select the type of diagnostic test you want to run, and then follow the on-screen instructions.

Downloading HP PC Hardware Diagnostics UEFI to a USB flash drive

Downloading HP PC Hardware Diagnostics UEFI to a USB flash drive can be useful in the following situations:

- HP PC Hardware Diagnostics UEFI is not included in the preinstall image.
- HP PC Hardware Diagnostics UEFI is not included in the HP Tool partition.
- The hard drive is damaged.



NOTE: The HP PC Hardware Diagnostics UEFI download instructions are provided in English only, and you must use a Windows computer to download and create the HP UEFI support environment because only .exe files are provided.

Downloading the latest HP PC Hardware Diagnostics UEFI version

To download the latest HP PC Hardware Diagnostics UEFI version to a USB flash drive:

1. Go to <http://www.hp.com/go/techcenter/pcdiags>. The HP PC Diagnostics home page is displayed.
2. In the **HP PC Hardware Diagnostics UEFI** section, select **Download UEFI Diagnostics**, and then select **Run**.

Downloading HP PC Hardware Diagnostics UEFI by product name or number (select products only)



NOTE: For some products, it may be necessary to download the software to a USB flash drive by using the product name or number.

To download HP PC Hardware Diagnostics UEFI by product name or number (select products only) to a USB flash drive:

1. Go to <http://www.hp.com/support>.
2. Enter the product name or number, select your computer, and then select your operating system.
3. In the **Diagnostics** section, follow the on-screen instructions to select and download the specific UEFI Diagnostics version for your computer.

Using Remote HP PC Hardware Diagnostics UEFI settings (select products only)

Remote HP PC Hardware Diagnostics UEFI is a firmware (BIOS) feature that downloads HP PC Hardware Diagnostics UEFI to your computer. It can then execute the diagnostics on your computer, and it may upload results to a preconfigured server. For more information on Remote HP PC Hardware Diagnostics UEFI, go to <http://www.hp.com/go/techcenter/pcdiags>, and then select **Find out more**.

Downloading Remote HP PC Hardware Diagnostics UEFI

 **NOTE:** HP Remote PC Hardware Diagnostics UEFI is also available as a Softpaq that can be downloaded to a server.

Downloading the latest Remote HP PC Hardware Diagnostics UEFI version

To download the latest Remote HP PC Hardware Diagnostics UEFI version, follow these steps:

1. Go to <http://www.hp.com/go/techcenter/pcdiags>. The HP PC Diagnostics home page is displayed.
2. In the **HP PC Hardware Diagnostics UEFI** section, select **Download Remote Diagnostics**, and then select **Run**.

Downloading Remote HP PC Hardware Diagnostics UEFI by product name or number

 **NOTE:** For some products, it may be necessary to download the software by using the product name or number.

To download HP Remote PC Hardware Diagnostics UEFI by product name or number, follow these steps:

1. Go to <http://www.hp.com/support>.
2. Select **Get software and drivers**, select your type of product, enter the product name or number in the search box that is displayed, select your computer, and then select your operating system.
3. In the **Diagnostics** section, follow the on-screen instructions to select and download the **Remote UEFI** version for the product.

Customizing Remote HP PC Hardware Diagnostics UEFI settings

Using the Remote HP PC Hardware Diagnostics setting in Computer Setup (BIOS), you can perform the following customizations:

- Set a schedule for running diagnostics unattended. You can also start diagnostics immediately in interactive mode by selecting **Execute Remote HP PC Hardware Diagnostics**.
- Set the location for downloading the diagnostic tools. This feature provides access to the tools from the HP website or from a server that has been preconfigured for use. Your computer does not require the traditional local storage (such as a disk drive or USB flash drive) to run remote diagnostics.
- Set a location for storing the test results. You can also set the user name and password settings used for uploads.
- Display status information about the diagnostics run previously.

To customize Remote HP PC Hardware Diagnostics UEFI settings, follow these steps:

1. Turn on or restart the computer, and when the HP logo appears, press **f10** to enter Computer Setup.
2. Select **Advanced**, and then select **Settings**.

3. Make your customization selections.
4. Select **Main**, and then **Save Changes and Exit** to save your settings.

Your changes take effect when the computer restarts.

9 Backing up, restoring, and recovering

This chapter provides information about the following processes, which are standard procedure for most products:

- **Backing up your personal information**—You can use Windows tools to back up your personal information (see [Using Windows tools on page 85](#)).
- **Creating a restore point**—You can use Windows tools to create a restore point (see [Using Windows tools on page 85](#)).
- **Creating recovery media** (select products only)—You can use the HP Cloud Recovery Download Tool (select products only) to create recovery media (see [Using the HP Cloud Recovery Download Tool to create recovery media \(select products only\) on page 85](#)).
- **Restoring and recovery**—Windows offers several options for restoring from backup, refreshing the computer, and resetting the computer to its original state (see [Using Windows tools on page 85](#)).

 **IMPORTANT:** If you will be performing recovery procedures on a tablet, the tablet battery must be at least 70% charged before you start the recovery process.

IMPORTANT: For a tablet with a detachable keyboard, connect the tablet to the keyboard base before beginning any recovery process.

Backing up information and creating recovery media

Using Windows tools

 **IMPORTANT:** Windows is the only option that allows you to back up your personal information. Schedule regular backups to avoid information loss.

You can use Windows tools to back up personal information and create system restore points and recovery media.

 **NOTE:** If computer storage is 32 GB or less, Microsoft System Restore is disabled by default.

For more information and steps, see the Get Help app.

1. Select the **Start** button, and then select the **Get Help** app.
2. Enter the task you want to perform.

 **NOTE:** You must be connected to the Internet to access the Get Help app.

Using the HP Cloud Recovery Download Tool to create recovery media (select products only)

You can use the HP Cloud Recovery Download Tool to create HP Recovery media on a bootable USB flash drive, as follows:

1. Go to <http://www.hp.com/support>.
2. Select **Software and Drivers**, and then follow the on-screen instructions.



NOTE: If you cannot create recovery media yourself, contact support to obtain recovery discs. Go to <http://www.hp.com/support>, select your country or region, and then follow the on-screen instructions.

Restoring and recovery

Restoring, resetting, and refreshing using Windows tools

Windows offers several options for restoring, resetting, and refreshing the computer. For details, see [Using Windows tools on page 85](#).

Recovering using HP Recovery media

HP Recovery media is used to recover the original operating system and software programs that were installed at the factory. On select products, it can be created on a bootable USB flash drive using the HP Cloud Recovery Download Tool. For details, see [Using the HP Cloud Recovery Download Tool to create recovery media \(select products only\) on page 85](#).



NOTE: If you cannot create recovery media yourself, contact support to obtain recovery discs. Go to <http://www.hp.com/support>, select your country or region, and then follow the on-screen instructions.

To recover your system:

- ▲ Insert the HP Recovery media, and then restart the computer.

Changing the computer boot order

If your computer does not restart using the HP Recovery media, you can change the computer boot order. This is the order of devices listed in BIOS where the computer looks for startup information. You can change the selection to an optical drive or a USB flash drive, depending on the location of your HP Recovery media.

To change the boot order:



IMPORTANT: For a tablet with a detachable keyboard, connect the tablet to the keyboard base before beginning these steps.

1. Insert the HP Recovery media.
2. Access the system **Startup** menu.

For computers or tablets with keyboards attached:

- ▲ Turn on or restart the computer or tablet, quickly press **esc**, and then press **f9** for boot options.

For tablets without keyboards:

- ▲ Turn on or restart the tablet, quickly hold down the volume up button, and then select **f9**.

– or –

Turn on or restart the tablet, quickly hold down the volume down button, and then select **f9**.

3. Select the optical drive or USB flash drive from which you want to boot, and then follow the on-screen instructions.

10 Specifications

Computer specifications

	Metric	U.S.
Dimensions		
Length	246.0 mm	10.72 in
Width	376.0 mm	16.33 in
Height	22.5 mm	0.97 in
Weight (lowest configuration)		
SSD, Pentium or Celeron processors, UMA graphics	1771.5 g	3.91 lbs
SSD, 7th/8th generation Core processors, UMA graphics	1829.5 g	4.03 lbs
SSD, discrete graphics	1855.5 g	4.09 lbs
HDD and ODD, Pentium or Celeron processors, UMA graphics	2004.7 g	4.42 lbs
HDD and ODD, 7th/8th generation Core processors, UMA graphics	2062.7 g	4.55 lbs
HDD and ODD, discrete graphics	2088.7 g	4.60 lbs
Input power		
Operating voltage	19.0 V dc @ 4.74 A – 90 W or 18.5 V dc @ 3.5 A - 65 W or 45 W	
Operating current	4.74 A or 3.5 A	
Temperature		
Operating (not writing to optical disc)	0°C to 35°C	32°F to 95°F
Operating (writing to optical disc)	5°C to 35°C	41°F to 95°F
Nonoperating	-20°C to 60°C	-4°F to 140°F
Relative humidity		
Operating	10% to 90%	
Nonoperating	5% to 95%	
NOTE: Applicable product safety standards specify thermal limits for plastic surfaces. The computer operates well within this range of temperatures.		

39.6-cm (15.6-in) display specifications

	Metric	U.S.
Active diagonal size	39.6-cm	15.6-in
Resolution	FHD: 1920×1080 HD: 1366×768	
Surface treatment	Anti-glare BrightView	
Brightness	220 nits 200 nits (BrightView, HD, Touch-on Panel)	
Viewing angle	SVA UWVA (FHD, anti glare panel)	
Backlight	WLED	
Aspect ratio	16:10 ultra wide	
Display panel interface	eDP	
Width	Slim-flat, 3.2 mm	

M.2 SATA solid-state drive specifications

	128-GB*	256-GB*
Height	1.35 mm	1.35 mm
Weight	< 10 g	< 10 g
Form factor	M.2 2280-D2-B-M	M.2 2280-D2-B-M
Transfer rate	up to 540 MB/sec	up to 540 MB/sec
Interface type	SATA-3	SATA-3
Ready time, maximum (to not busy)	1.0 ms	< 1.0 ms
Access times, logical	0.1 ms	0.1 ms
Total logical sectors	234,441,648	468,883,296
Operating temperature	0°C to 70°C (32°F to 158°F)	

*1 GB = 1 billion bytes when referring to hard drive storage capacity. Actual accessible capacity is less. Actual drive specifications may differ slightly.

NOTE: Certain restrictions and exclusions apply. Contact technical support for details.

M.2 PCIe solid-state drive specifications

	256-GB*	512-GB*
Dimensions		
Height	1 mm	1 mm
Length	50.8 mm	50.8 mm
Width	28.9 mm	28.9 mm
Weight	< 10 g	< 10 g
Interface type		
	ATA-7	ATA-7
Transfer rate		
Sequential Read	Up to 2150 MB/s	Up to 2150 MB/s
Random Read	Up to 300,000 IOPs	Up to 300,000 IOPs
Sequential Write	Up to 1260 MB/s	Up to 1550 MB/s
Random Write	Up to 100,000 IOPs	Up to 100,000 IOPs
Ready time, Maximum (to not busy)		
	1.0 s	1.0 s
Access times		
Logical	0.1 ms	0.1 ms
Total logical sectors		
	500,118,192	1,000,215,216
Operating temperature		
Operating	0° to 70°C (32°F to 158°F)	0° to 70°C (32°F to 158°F)
Non-operating	-40° to 80°C (-40°F to 176°F)	-40° to 85°C (-40°F to 185°F)

*1 GB = 1 billion bytes when referring to hard drive storage capacity. Actual accessible capacity is less.

NOTE: Certain restrictions and exclusions apply. Contact technical support for details.

Hard drive specifications

	2-TB*	1-TB*	500-GB*
Dimensions			
Height	7.2 mm or 9.5 mm	7.2 mm or 9.5 mm	7.0 mm
Length	100.4 mm	100.4 mm	100.6 mm
Width	69.9 mm	69.9 mm	70.1 mm
Weight	130.0 g	107.0 g	92.0 g
Interface type	SATA	SATA	SATA
Transfer rate			
Synchronous (maximum)	300 MB/sec	300 MB/sec	300 MB/sec
Security	ATA security	ATA security	ATA security
Seek times (typical read, including setting)			
Single track	2.0 ms	2.0 ms	3 ms
Average (read/write)	12 ms	12 ms	13 ms
Maximum	22 ms	22 ms	24 ms
Logical blocks	3,907,029,168	1,953,525,168	1,048,576,000
Disk rotational speed	5400 rpm	5400 rpm	5400 rpm
Operating temperature	0°C to 60°C (32°F to 140°F)		
*1 GB = 1 billion bytes when referring to hard drive storage capacity. Actual accessible capacity is less.			
NOTE: Certain restrictions and exclusions apply. Contact technical support for details.			

11 Power cord set requirements

The wide-range input feature of the computer permits it to operate from any line voltage from 100 to 120 volts AC, or from 220 to 240 volts AC.

The 3-conductor power cord set included with the computer meets the requirements for use in the country or region where the equipment is purchased.

Power cord sets for use in other countries and regions must meet the requirements of the country or region where the computer is used.

Requirements for all countries

The following requirements are applicable to all countries and regions:

- The length of the power cord set must be at least **1.0 m** (3.3 ft) and no more than **2.0 m** (6.5 ft).
- All power cord sets must be approved by an acceptable accredited agency responsible for evaluation in the country or region where the power cord set will be used.
- The power cord sets must have a minimum current capacity of 10 amps and a nominal voltage rating of 125 or 250 V AC, as required by the power system of each country or region.
- The appliance coupler must meet the mechanical configuration of an EN 60 320/IEC 320 Standard Sheet C13 connector for mating with the appliance inlet on the back of the computer.

Requirements for specific countries and regions

Country/region	Accredited agency	Applicable note number
Australia	EANSW	1
Austria	OVE	1
Belgium	CEBC	1
Canada	CSA	2
Denmark	DEMKO	1
Finland	FIMKO	1
France	UTE	1
Germany	VDE	1
Italy	IMQ	1
Japan	METI	3
The Netherlands	KEMA	1
Norway	NEMKO	1
The People's Republic of China	COC	5
South Korea	EK	4

Country/region	Accredited agency	Applicable note number
Sweden	SEMKO	1
Switzerland	SEV	1
Taiwan	BSMI	4
The United Kingdom	BSI	1
The United States	UL	2

1. The flexible cord must be Type H05VV-F, 3-conductor, 1.0-mm² conductor size. Power cord set fittings (appliance coupler and wall plug) must bear the certification mark of the agency responsible for evaluation in the country or region where it will be used.
2. The flexible cord must be Type SPT-3 or equivalent, No. 18 AWG, 3-conductor. The wall plug must be a two-pole grounding type with a NEMA 5-15P (15 A, 125 V) or NEMA 6-15P (15 A, 250 V) configuration.
3. The appliance coupler, flexible cord, and wall plug must bear a “T” mark and registration number in accordance with the Japanese Dentori Law. The flexible cord must be Type VCT or VCTF, 3-conductor, 1.00-mm² conductor size. The wall plug must be a two-pole grounding type with a Japanese Industrial Standard C8303 (7 A, 125 V) configuration.
4. The flexible cord must be Type RVV, 3-conductor, 0.75-mm² conductor size. Power cord set fittings (appliance coupler and wall plug) must bear the certification mark of the agency responsible for evaluation in the country or region where it will be used.
5. The flexible cord must be Type VCTF, 3-conductor, 0.75-mm² conductor size. Power cord set fittings (appliance coupler and wall plug) must bear the certification mark of the agency responsible for evaluation in the country or region where it will be used.

12 Recycling

When a non-rechargeable or rechargeable battery has reached the end of its useful life, do not dispose of the battery in general household waste. Follow the local laws and regulations in your area for battery disposal.

HP encourages customers to recycle used electronic hardware, HP original print cartridges, and rechargeable batteries. For more information about recycling programs, see the HP Web site at <http://www.hp.com/recycle>.

Index

- A**
 - AC adapter and battery light, identifying 7
 - AC adapter, spare part numbers 25
 - action keys
 - airplane mode 13
 - help 13
 - identifying 12, 13
 - keyboard backlight 13
 - mute 13
 - next track 13
 - pause 13
 - play 13
 - screen brightness 13
 - speaker volume 13
 - switch screen image 13
 - using 13
 - airplane mode key 13
 - antenna
 - removal 68
 - audio
 - adjusting volume 13
 - audio, product description 3
 - audio-out (headphone)/audio-in (microphone) combo jack, identifying 7
- B**
 - back cover
 - spare part number 23
 - backup, creating 85
 - backups 85
 - battery
 - removal 41
 - spare part number 19, 41
 - BIOS
 - determining version 78
 - downloading an update 79
 - starting the Setup Utility 78
 - updating 78
 - Bluetooth label 15
 - boot order, changing 86
 - bottom components 14
 - bottom cover
 - removal 38
 - spare part number 19, 38
 - buttons
 - left TouchPad 9
 - optical drive eject 6
 - power 11
 - right TouchPad 9
- C**
 - camera
 - identifying 8
 - product description 3
 - camera light, identifying 8
 - camera module
 - spare part number 23
 - camera/microphone module
 - spare part numbers 65
 - caps lock light, identifying 10
 - chipset, product description 1
 - components
 - bottom 14
 - display 8
 - keyboard area 9
 - left side 7
 - right side 6
 - computer major components 16
 - computer specifications 87
 - connector, power 7
- D**
 - Display assembly
 - spare part numbers 17
 - display assembly
 - removal 62
 - subcomponents 22
 - display assembly components
 - removal 62
 - spare part numbers 62
 - display bezel
 - removal 64
 - spare part numbers 23, 64
 - display cable, spare part number 23
 - display components 8
 - display panel
 - product description 2
 - removal 65
 - display panel cable
 - removal 68
 - spare part numbers 68
 - display specifications 88
 - drive light, identifying 6
 - DVD+/-RW Double-Layer Writer
 - spare part number 19, 26, 34
- E**
 - esc key, identifying 12
 - ethernet
 - product description 3
- F**
 - fan
 - removal 57
 - spare part number 18, 57
 - fn key, identifying 12
- G**
 - Get Help in Windows 10 action key 13
- H**
 - hard drive
 - product description 2
 - removal 45
 - spare part number 19, 26
 - spare part numbers 45
 - specifications 90
 - hard drive bracket
 - spare part number 27
 - hard drive connector board
 - removal 52
 - spare part number 18, 27, 52
 - hard drive/solid-state drive cable
 - spare part number 27
 - HDMI port
 - identifying 7
 - heat sink
 - spare part numbers 19

- heat sink assembly
 - removal 58
 - spare part numbers 58
- hinge
 - removal 67
 - spare part number 68
- hinge cover
 - spare part number 22
- Hinge Kit
 - spare part number 23
- HP PC Hardware Diagnostics UEFI
 - downloading 82
 - starting 82
 - using 81
- HP PC Hardware Diagnostics Windows
 - downloading 80
 - installing 81
 - using 80
- HP Recovery media
 - recovery 86

I

- integrated numeric keypad, identifying 12
- internal microphones, identifying 8

J

- jacks
 - audio-out (headphone)/audio-in (microphone) 7
 - network 7
 - RJ-45 (network) 7

K

- keyboard
 - product description 4
 - removal 77
 - spare part number 77
 - spare part numbers 17
- keyboard backlight action key 13
- keypad, integrated numeric 12
- keys
 - action 12
 - airplane mode 13
 - esc 12
 - fn 12
 - num lock 12
 - Windows 12

L

- labels
 - Bluetooth 15
 - regulatory 15
 - serial number 15
 - service 15
 - wireless certification 15
 - WLAN 15
- left side components 7
- lights
 - AC adapter and battery 7
 - camera 8
 - caps lock 10
 - drive 6
 - mute 10
 - power 6
 - RJ-45 (network) status 7

M

- M.2 solid-state drive
 - specifications 89
- memory
 - product description 2
 - removal 43
 - spare part number 18
 - spare part numbers 43
- MicroSD memory card reader, identifying 6
- model name 1
- mute light, identifying 10
- mute volume action key 13

N

- network jack, identifying 7
- next track action key 13

O

- operating system, product description 4
- Optane memory module
 - removal 50
 - spare part number 50
 - spare part numbers 50
- optical drive
 - product description 3
 - removal 34
 - spare part numbers 34
- optical drive eject button, identifying 6
- optical drive, identifying 6

P

- panel
 - spare part numbers 23
- pause action key 13
- play action key 13
- pointing device, product description 4
- ports
 - HDMI 7
 - product description 3
 - USB 6
 - USB SuperSpeed 7
- power button, identifying 11
- power connector
 - identifying 7
- power connector cable
 - removal 76
 - spare part numbers 76
- power cord
 - set requirements 91
- power lights, identifying 6
- power requirements, product description 4
- processor 1
- product description
 - audio 3
 - camera 3
 - chipset 1
 - display panel 2
 - ethernet 3
 - external media cards 3
 - hard drive 2
 - keyboard 4
 - memory 2
 - operating system 4
 - optical drive 3
 - pointing device 4
 - ports 3
 - power requirements 4
 - processor 1
 - product name 1
 - security 4
 - serviceability 5
 - wireless networking 3
- product name 1
- product name and number, computer 15

R

- recovery 85
 - discs 86
 - HP Recovery partition 86
 - media 86
 - USB flash drive 86
- recovery media
 - creating using HP Cloud Recovery Download Tool 85
 - creating using Windows tools 85
- regulatory information
 - regulatory label 15
 - wireless certification labels 15
- Remote HP PC Hardware Diagnostics UEFI settings
 - customizing 83
 - using 83
- removal/replacement
 - procedures 33, 37
- restoring 85
- right side components 6
- RJ-45 (network) jack, identifying 7
- RJ-45 (network) status lights, identifying 7

S

- screen brightness action keys 13
- Screw Kit, spare part numbers 25
- security cable slot, identifying 6
- security, product description 4
- serial number, computer 15
- service labels, locating 15
- serviceability, product description 5
- slots
 - memory card reader 6
 - security cable 6
- solid-state drive
 - removal 47
 - spare part number 18, 27
 - spare part numbers 47
 - specifications 88
- solid-state drive bracket and connector board
 - removal 48
 - spare part numbers 48
- solid-state drive cable
 - spare part number 27
- solid-state drive connector board
 - spare part number 18
- speaker volume action keys 13

speakers

- identifying 11
 - removal 75
 - spare part number 17
 - spare part numbers 75
- ## special keys, using 12
- ## specifications
- computer 87
 - display 88
 - hard drive 90
 - M.2 solid-state drive 89
 - solid-state drive 88
- ## switch screen image action key 13
- ## system board
- removal 72
 - spare part number 17
 - spare part numbers 72
- ## system restore point, creating 85

T

- ## top cover
- removal 77
 - spare part number 77
- ## top cover/keyboard
- spare part numbers 17
- ## TouchPad button board
- removal 54
 - spare part number 17
 - spare part numbers 54
- ## TouchPad buttons
- identifying 9
- ## TouchPad module
- removal 55
 - spare part number 17, 55
- ## TouchPad zone, identifying 9
- ## traveling with the computer 15

U

- USB port, identifying 6
 - USB SuperSpeed port, identifying 7
- ## USB/card reader board
- removal 53
 - spare part number 19, 53

V

- vents, identifying 11, 14
- ## volume
- adjusting 13
 - mute 13

W

- ## webcam/microphone module
- removal 64
- ## Windows
- backup 85
 - recovery media 85
 - system restore point 85
- ## Windows key, identifying 12
- ## Windows tools, using 85
- ## wireless antenna
- removal 68
- ## wireless certification label 15
- ## wireless networking
- product description 3
- ## WLAN
- removal 51
 - spare part numbers 51
- ## WLAN antenna
- removal 68
- ## WLAN antennas, identifying 8
- ## WLAN cable
- spare part number 23
- ## WLAN device 15
- ## WLAN label 15
- ## WLAN module
- spare part number 18